

# **H&S** PARTS BOOK

## **S3123 SPREADER**



Revision #02  
Starting Ser. #613629

Part #72934  
HSMFG0317

**P.O. BOX 768, MARSHFIELD, WI 54449  
(715) 387-3414 FAX (715) 384-5463  
[www.hsmfgco.com](http://www.hsmfgco.com)**

# CONTENTS

Instructions for Ordering Parts .....	1
Figure 1 - Beater and Pan Assembly .....	2-3
Figure 2 - Hub, Spindle and Box Parts .....	4-5
Figure 3 - Front Shield and Drive Assembly .....	6-9
Figure 4 - Back Shield and Drive Assembly .....	10-13
Figure 5 - Hydraulic Endgate .....	14-15
Figure 6 - Apron Chain Assembly .....	16
Figure 7 - Hydraulic Endgate Cylinder .....	17
Figure 8 - PTO .....	18
Figure 9- Optional Second Beater .....	19
Figure 10 -Gearbox .....	20-23
Figure 11 -4 Hose Hydraulic Drive Assembly .....	24-25
Figure 12 -2 Hose Hydraulic Drive Assembly .....	26-27
Figure 13 - Hydraulic Drive Gearbox .....	28-29
Parts Notes .....	30

# **INSTRUCTIONS FOR ORDERING PARTS**

All service parts should be ordered through your authorized H&S dealer. He will be able to give you faster service if you will provide them with the following:

1. Model & Serial Number - Both can be located on the side of the center bearing post above jack mount.
2. All references to left or right apply to the machine as viewed from the rear.
3. Parts should not be ordered from illustration only. Please order complete part number.
4. If your dealer has to order parts - give shipping instructions:

VIA truck - large pieces (please specify local truck lines)

VIA United Parcel Service (include full address)

Via FED EX (Include Full Address)

<b>H&amp;S MFG. CO. INC.</b>	
MARSHFIELD, WIS.	
MOD. NO.	<input type="text"/>
SER. NO.	<input type="text"/>
DESCR.	<input type="text"/>

PLEASE RECORD NUMBERS FOR YOUR UNIT FOR QUICK REFERENCE

## **ABOUT IMPROVEMENTS**

H&S MFG. CO. INC. IS CONTINUALLY STRIVING TO IMPROVE IT'S PRODUCTS

We must therefore, reserve the right to make improvements or changes whenever it becomes practical to do so, without incurring any obligation to make changes or additions to the equipment previously sold.

**FIGURE 1**  
**BEATER/PAN ASSEMBLY**

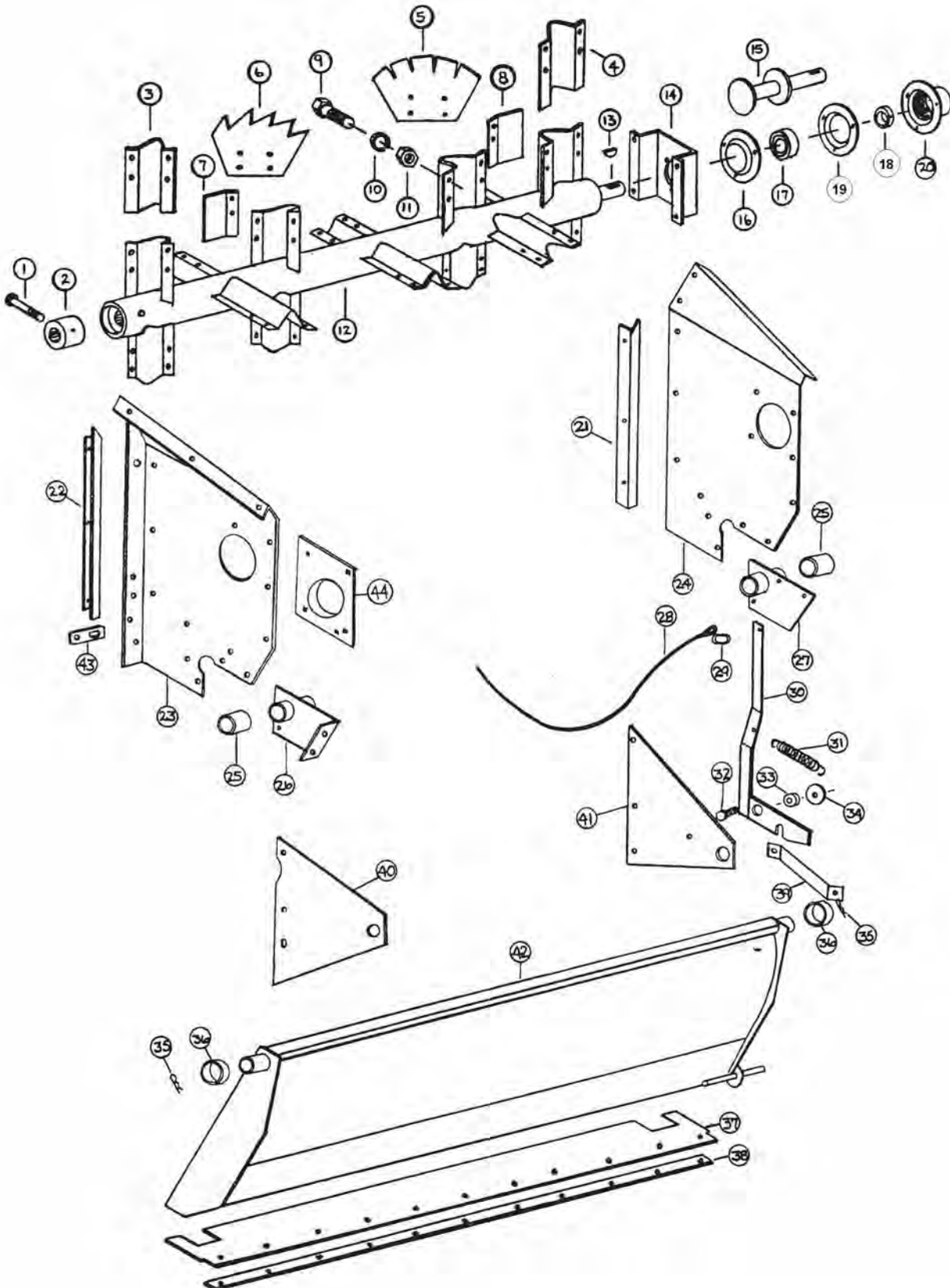

# FIGURE 1

## BEATER/PAN ASSEMBLY

<u>ITEM</u>	<u>PART #</u>	<u>DESCRIPTION</u>
1	YBHH10130	BOLT, 5/16" X 5" GR. 5
2	23N2	SPLINED BEATER INSERT
3	23N3	BEATER BLADE HOLDER LH
4	23N4	BEATER BLADE HOLDER RH
5	23N276	BEATER BLADE - HARDENED
6	23N277	BEATER BLADE - HARDENED
7	23N7	BEATER BLADE WIPER LH
8	23N8	BEATER BLADE WIPER RH
9	YBHH16045	BOLT, 1/2" X 1-1/4" GR. 5
10	YWLO16005	WASHER, LOCK, 1/2"
11	YNTL16005	HEX NUT, TOP LOCK, 1/2"-13
12	23N263	BEATER
13	5B9	3/8" X 1-1/4" WOODRUFF KEY
14	23N10	BEATER SHAFT SUPPORT
15	23N11	BEATER STUB SHAFT
16	F116	BEARING FLANGE (HEAVY DUTY)
17	12N122	BEARING W/ LOCK COLLAR ASSY.
18	12N122	BEARING W/ LOCK COLLAR ASSY.
19	F114A	BEARING FLANGE W/ ZERK 45 DEGREE
20	23N12	BEARING FLANGE GUARD
21	23N13	RH SIDE POLY HOLD DOWN
22	23N14	LH SIDE POLY HOLD DOWN
23	23N264	LH MAIN PANEL
24	23N265	RH MAIN PANEL
25	23N17	DRIVE SHAFT BUSHING
26	23N257	DRIVE SHAFT BRACKET LH
27	23N19	DRIVE SHAFT BRACKET RH
28	23N20	PAN TRIP ROPE
29	R31	CLIP
30	23N2	PAN TRIP LEVER
31	R27	SPRING
32	YBCR16010	CARRIAGE. BOLT, 1/2" X 1-1/2" GR. 5
33	23N23	TRIP LEVER SPACER
34	YWFL16005	WASHER, FLAT, 1/2" USS
35	YPCT06020	COTTER PIN, 3/16" X 2"
36	F112	SPACER
37	23N24	PAN RUBBER FLAP
38	23N25	PAN STRAP
39	23N267	PAN SUPPORT BRACE
40	23N268	LH PAN SUPPORT
41	23N29	RH PAN SUPPORT
42	23N30	PAN
43	23N64	SHIELD BRACKET
44	17G10	LH ANTI-WRAP GUARD

# FIGURE 2

## SPINDLE/HUB/BOX PARTS

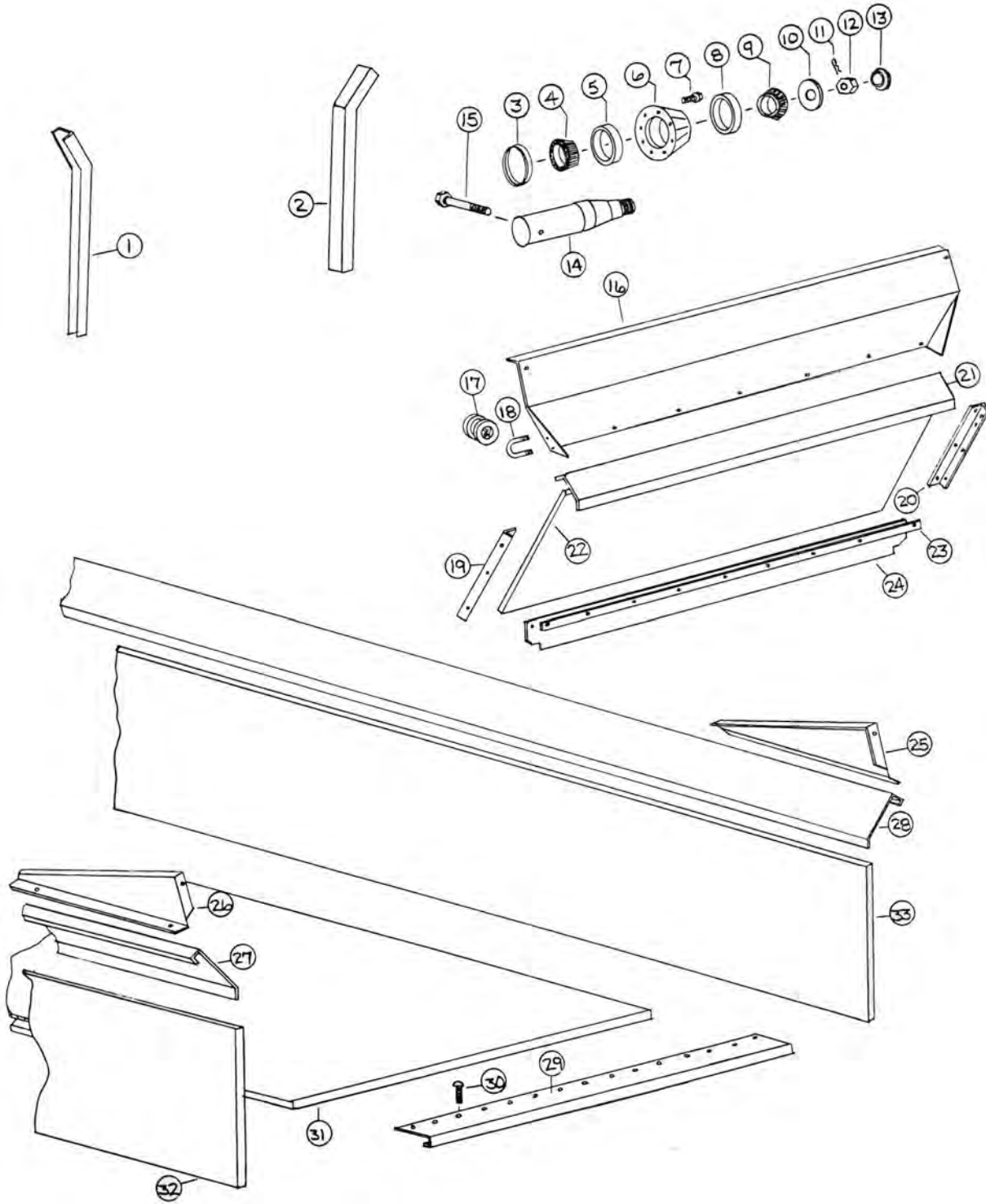



## FIGURE 2

### SPINDLE/HUB/BOX PARTS

<u>ITEM</u>	<u>PART #</u>	<u>DESCRIPTION</u>
1	23N31	RH SIDE STAKE
2	23N32	LH SIDE STAKE
3	B8	SEAL
4	B7	INNER BEARING
5	B7A	INNER RACE
6	B6	HUB
7	YBWL18005	BOLT, WHEEL, 9/16-18X1-1/8, GR5, ZC
8	B5A	OUTER RACE
9	B5	OUTER BEARING
10	YWFL28005	WASHER, FLAT, 7/8" USS
11	YPCT05020	COTTER PIN, 5/32" X 1-3/4"
12	YNSL28005	HEX NUT, SLOTTED, 7/8"-14
13	B2	HUB CAP
14	B9	SPINDLE
*	23N304	SPINDLE FOR 14 X 16.1 WHEEL
15	YBHH16130	BOLT, 1/2" X 4" GR. 5
16	23N34	FRONT FLARE
17	F33	ROPE GUIDE
18	YBPU08005	PIPE U BOLT, 1/4"-20 X 3/4" PIPE, 1-1/4" ID, 2-1/4" IL, 1-1/4" THREAD
19	23N35	RH GATE ANGLE
20	23N36	LH GATE ANGLE
21	23N176	FRONT FLARE SUPPORT
22	23N270A	FRONT GATE PLYWOOD WITH FIBERGLASS
23	23N40	STRAP FOR RUBBER
24	23N41	FRONT GATE RUBBER
25	23N42	SPLASH GUARD SIDE LH
26	23N43	SPLASH GUARD SIDE RH
27	23N177	RH SIDE FLARE
28	23N178	LH SIDE FLARE
29	23N46	FRONT POLY FLOOR HOLD DOWN
30	B106	BOLTS FOR POLY FLOOR
31	23N271	FLOOR PLYWOOD WITH POLY
32	23N272A	RH SIDE PLYWOOD WITH FIBERGLASS
33	23N273A	LH SIDE PLYWOOD WITH FIBERGLASS
*	12V36	WHEEL 14 X 16.1
*	23N179	WHEEL 8 X 22.5
*	UR19	TIRE, 295/75R22.5, RECAP, HIGHWAY TREAD 1/2 X 1-3/4" GRADE 5 CARRIAGE BOLT

\* MEANS NOT SHOWN

# FIGURE 3

## FRONT SHIELDS/DRIVE ASSEMBLY

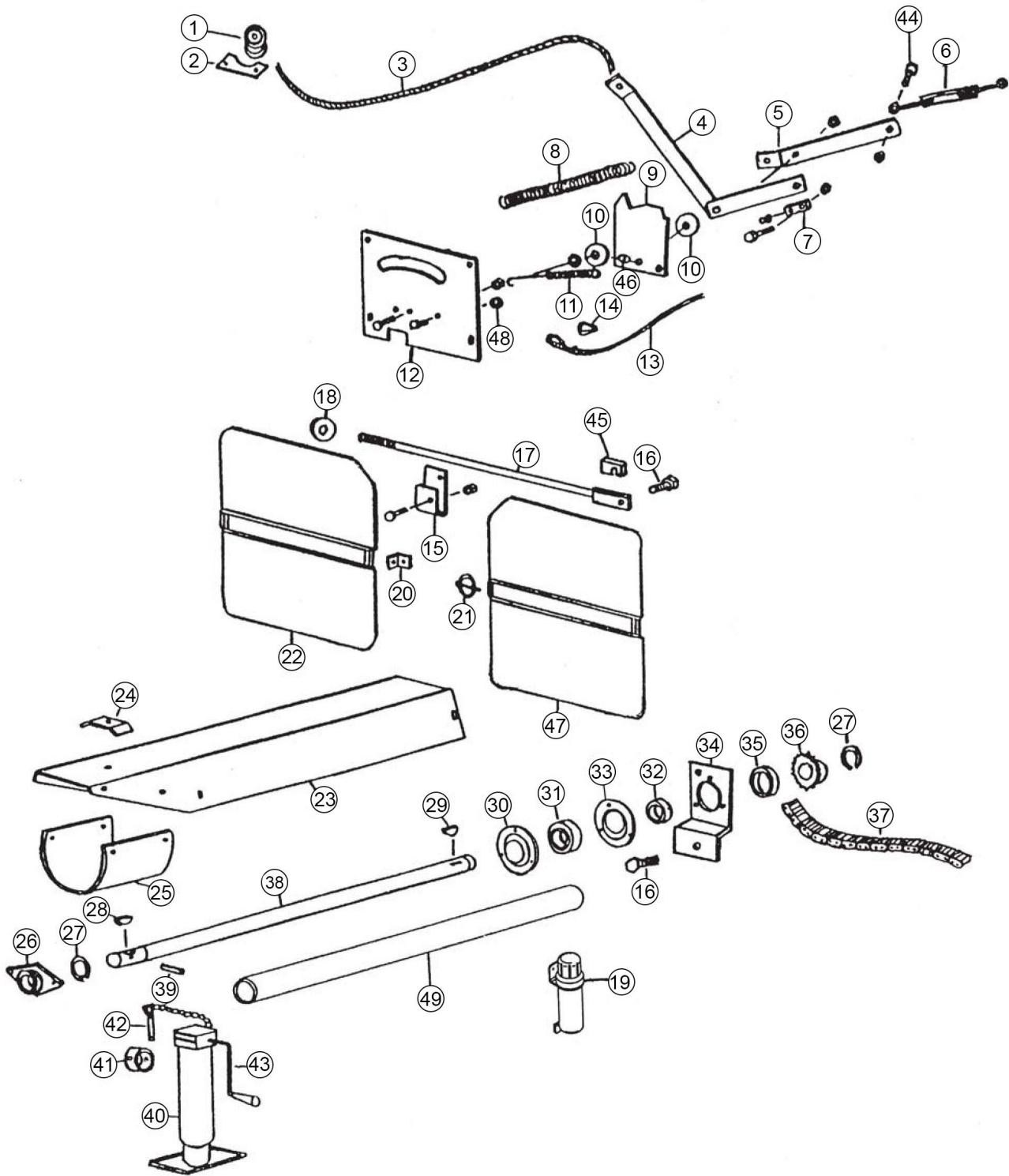



**FIGURE 3**  
**FRONT SHIELDS/DRIVE ASSEMBLY**

<b><u>ITEM</u></b>	<b><u>PART #</u></b>	<b><u>DESCRIPTION</u></b>
1	F33	CABLE GUIDE
2	23N182	BRACKET
3	23N183	ROPE - 15'
4	23N280	SHIFTER LEVER
5	23N281	PIVOT LINK
6	F84	TURNBUCKLE
7	23N282	SHIFTER DOG
8	10R14	SPRING
9	23N283	STOP BRACKET
10	YWCU12005	WASHER, CUSTOM, FLAT, .435" ID. X 1-7/8" OD. X .125 THICK
11	23N284	SHIFTER DOG SPRING
12	23N285	FRONT PANEL
13	23N286	CABLE
14	F44	CABLE LOOP
15	23N287	SPRING BRACKET
16	YBHH16045	BOLT, 1/2" X 1-1/4" GR. 5
17	23N63	TIGHTENER ROD
18	F129	WASHER
19	S522	MANUAL HOLDER
20	F92	SHIELD BRACKET
21	S122	LANYARD, CLIP PIN CABLE
22	23N305	FRONT SHIELD RH
23	23N66	SHIELD
24	23N67	TAILGATE HOSE BRACKET
*	HE42	HYDRAULIC DRIVE BRACKET
25	F54	SHIELD
26	12N29	BEARING
27	F73	SNAP RING

**\* MEANS NOT SHOWN**

# FIGURE 3

## FRONT SHIELDS/DRIVE ASSEMBLY

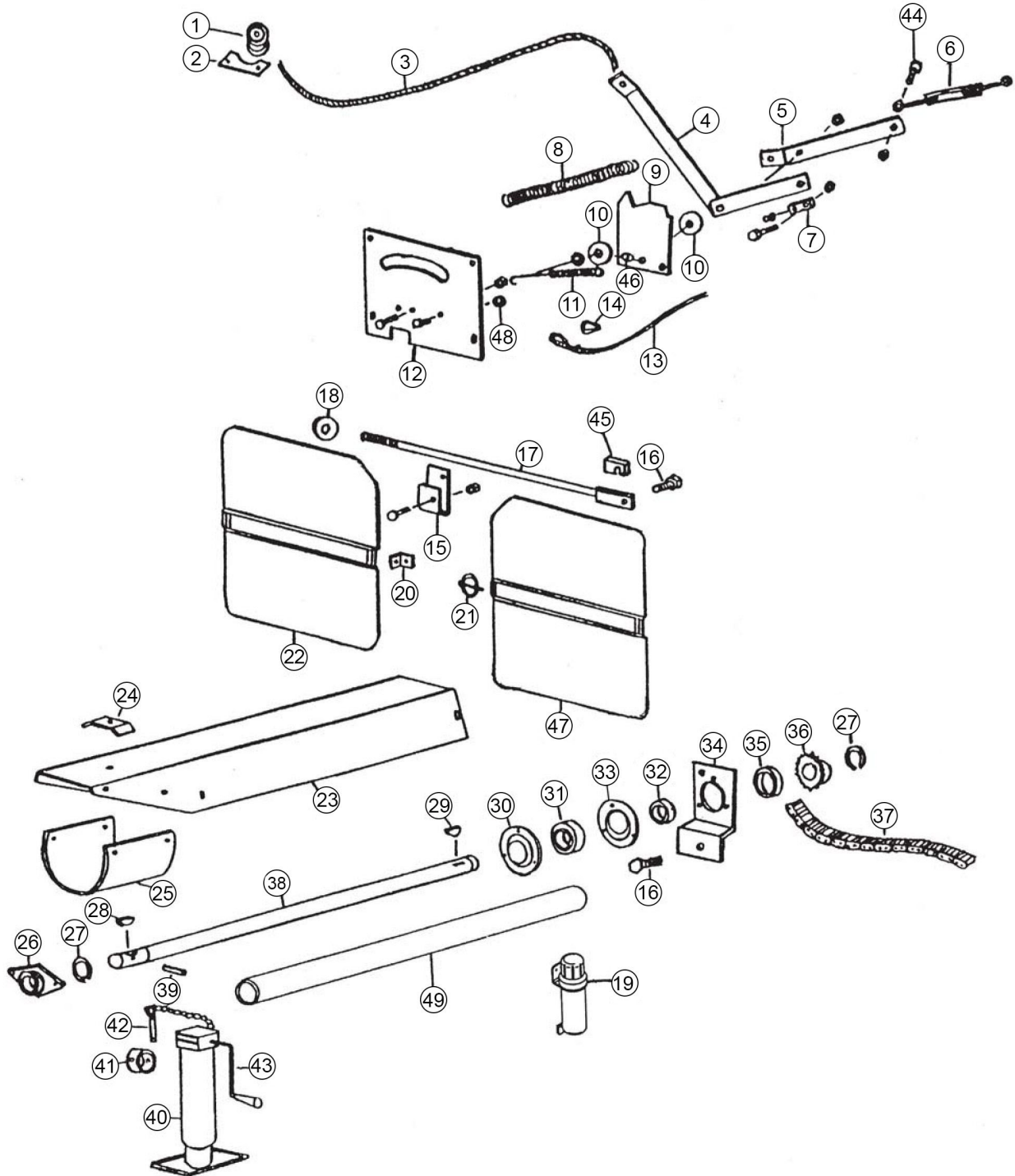

# FIGURE 3

## FRONT SHIELDS/DRIVE ASSEMBLY

<u>ITEM</u>	<u>PART #</u>	<u>DESCRIPTION</u>
28	5B10	1/4" X 1" KEY
29	5B9	3/8" X 1-1/4" WOODRUFF KEY
30	F114A	FLANGE, 1-1/4" W/45 DEG. ZERK
31	12N122	BEARING W/ LOCK COLLAR ASSY.
32	12N122	BEARING W/ LOCK COLLAR ASSY.
33	F14	BEARING FLANGE
34	23N68	FRONT ADJUSTMENT PLATE
35	23N69	SPACER
36	23N70	25 TOOTH SPROCKET
37	23N245	#60 ROLLER CHAIN 125 PITCHES
38	23N72	FRONT SHAFT
39	YPEX10020	EXPANSION PIN, 5/16" X 2-1/4"
40	12N116	JACK
*	12N120	JACK GEAR REP. KIT
41	12N121	JACK MOUNT
42	12N117	JACK PIN
43	12N119	HANDLE
*	12N118	REPLACEMENT BEARING
44	YBCR12010	CARRIAGE BOLT, 3/8" X 1" GR. 5 SPACER
45	23N278	ROLLER
46	23N297	TUBE, RND, STR, 0.75 X 0.19 X 0.21, DOM
47	23N306	FRONT SHIELD, LH
48	ST81	SPACER
49	37N74	FRONT SHAFT GUARD

**\* MEANS NOT SHOWN**

**FIGURE 4**  
**BACK SHIELDS/DRIVE ASSEMBLY**

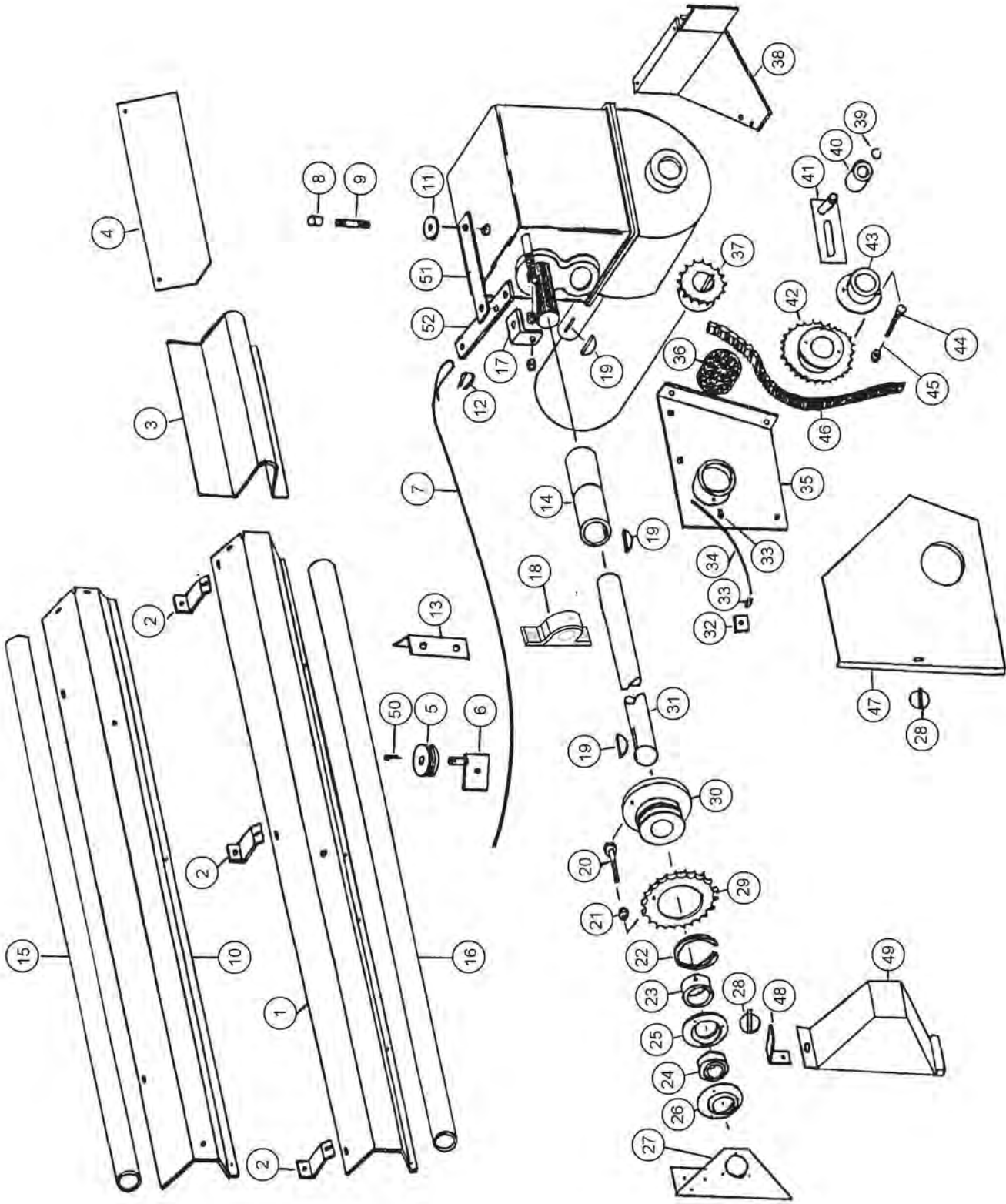

# FIGURE 4

## BACK SHIELDS/DRIVE ASSEMBLY

<u>ITEM</u>	<u>PART #</u>	<u>DESCRIPTION</u>
1	23N247	SIDE SHIELD
2	23N248	SIDE SHIELD BRACKET
3	23N292	COUPLER SHIELD
4	23N250	POLY SHIELD
5	23N251	POLY PULLEY
6	23N252	PULLEY MOUNT
7	23N253	CABLE
8	17G58	VENT CAP
9	23N288	PIPE NIPPLE
10	27N34	BACK SIDE SHIELD
11	17G61	WASHER
12	F44	CABLE LOOP
13	23N269	BEARING BRACKET
14	17G65	COUPLER
15	23N295	2ND SIDE SHAFT GUARD
*	27N43	3RD SIDE SHAFT GUARD
*	27N44	4TH SIDE SHAFT GUARD
16	23N294	1ST SIDE SHAFT GUARD
17	23N291	SHIFTER ROD ANGLE
18	12N36	COMPLETE ASSEMBLY
19	B59	3/8" X 1-1/4" WOODRUFF KEY
20	YBHH10030	BOLT, 5/16" X 1-1/2" GR. 5
21	YNTL10005	HEX NUT, TOP LOCK, 5/16"-18
22	23N189	SNAP RING
23	12N122	BEARING W/ LOCK COLLAR
24	12N122	ASSY. BEARING W/ LOCK
25	F114A	COLLAR ASSY. FLANGE
26	F14	BEARING FLANGE
27	23N254	SIDE BEARING PANEL LANYARD,
28	S122	CLIP PIN CABLE.
29	23N191	30 TOOTH SPROCKET
30	23N190	SHEAR HUB
31	23N255	SIDE SHAFT



**FIGURE 4**  
**BACK SHIELDS/DRIVE ASSEMBLY**

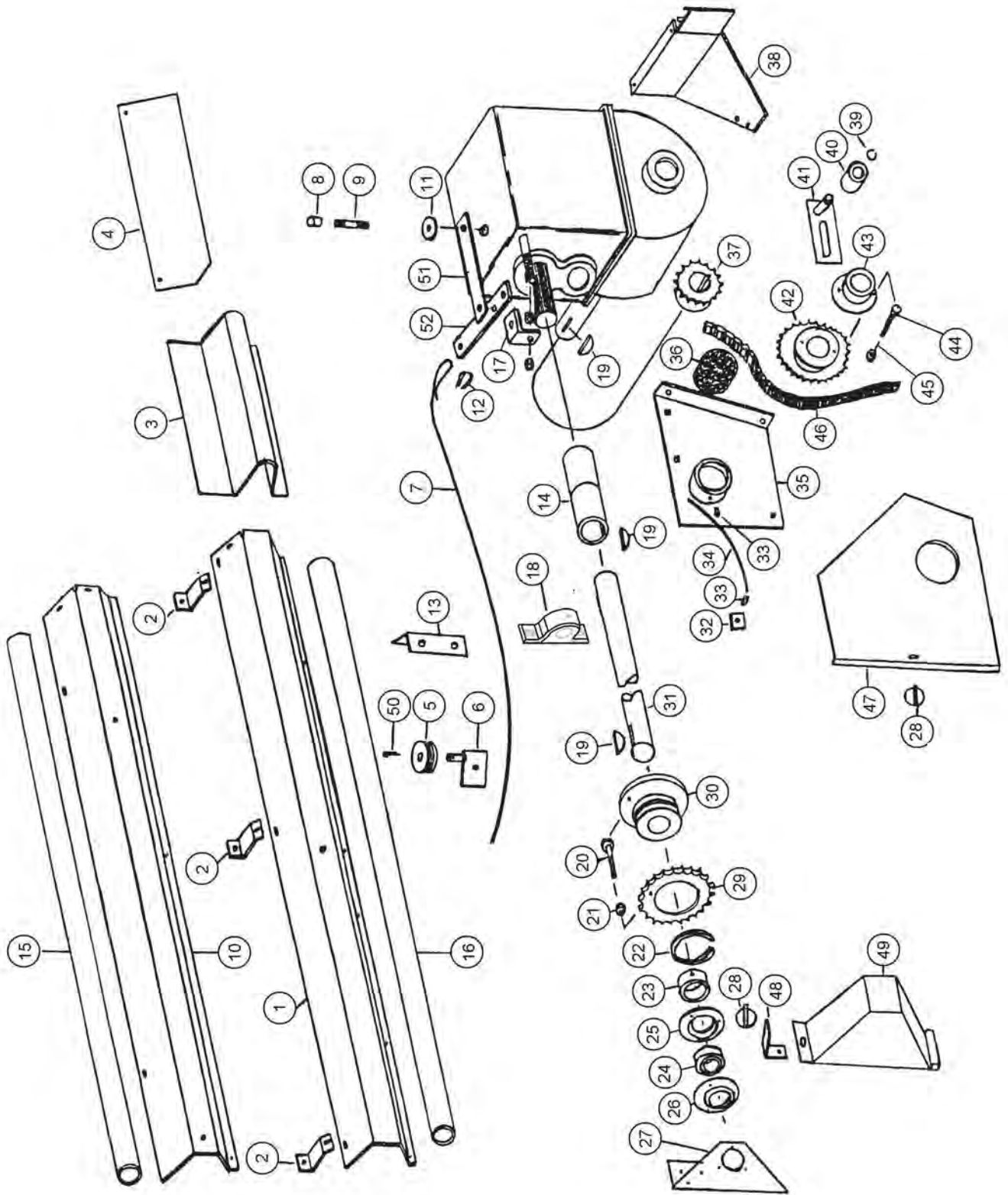



## FIGURE 4

### BACK SHIELDS/DRIVE ASSEMBLY

<u>ITEM</u>	<u>PART #</u>	<u>DESCRIPTION</u>
32	16V9	GREASE ZERK BLOCK
33	S47	GREASE LINE FITTING
34	23N256	GREASE LINE
35	23N257	LH DRIVE SHAFT MOUNT
36	23N258	CHAIN OILER
37	17G67	WORM GEAR SPROCKET
38	23N259	GEARBOX BRACE
39	10R32	SNAP RING
40	23N238	CHAIN TIGHTENER ROLLER
41	17G69	ASSY, CHAIN TIGHTENER BRACKET
42	17G68	SHEAR HUB SPROCKET - STANDARD (32T)
*	17G170	SLOW DOWN SPROCKET (40T)
*	23N279	SPEED UP SPROCKET (25T)
43	17G71	SHEAR HUB
44	YBHH10030	BOLT, 5/16" X 1-1/2" GR. 5
45	YNL10005	HEX NUT, TOP LOCK, 5/16"-18
46	23N260	#60 CHAIN 56 PITCHES
47	23N261	DRIVE SHIELD
48	23N242	SHIELD ANGLE
49	22G21	SHIELD
50	YPCT04005	COTTER PIN, 1/8" X 1"
51	23N289	SHIFTER ROD LEVER FULCRUM SHIFTER
52	23N290	ROD LEVER
53	23N291	SHIFTER ROD ANGLE

\* MEANS NOT SHOWN

**FIGURE 5**  
**HYDRAULIC ENDGATE ASSEMBLY**

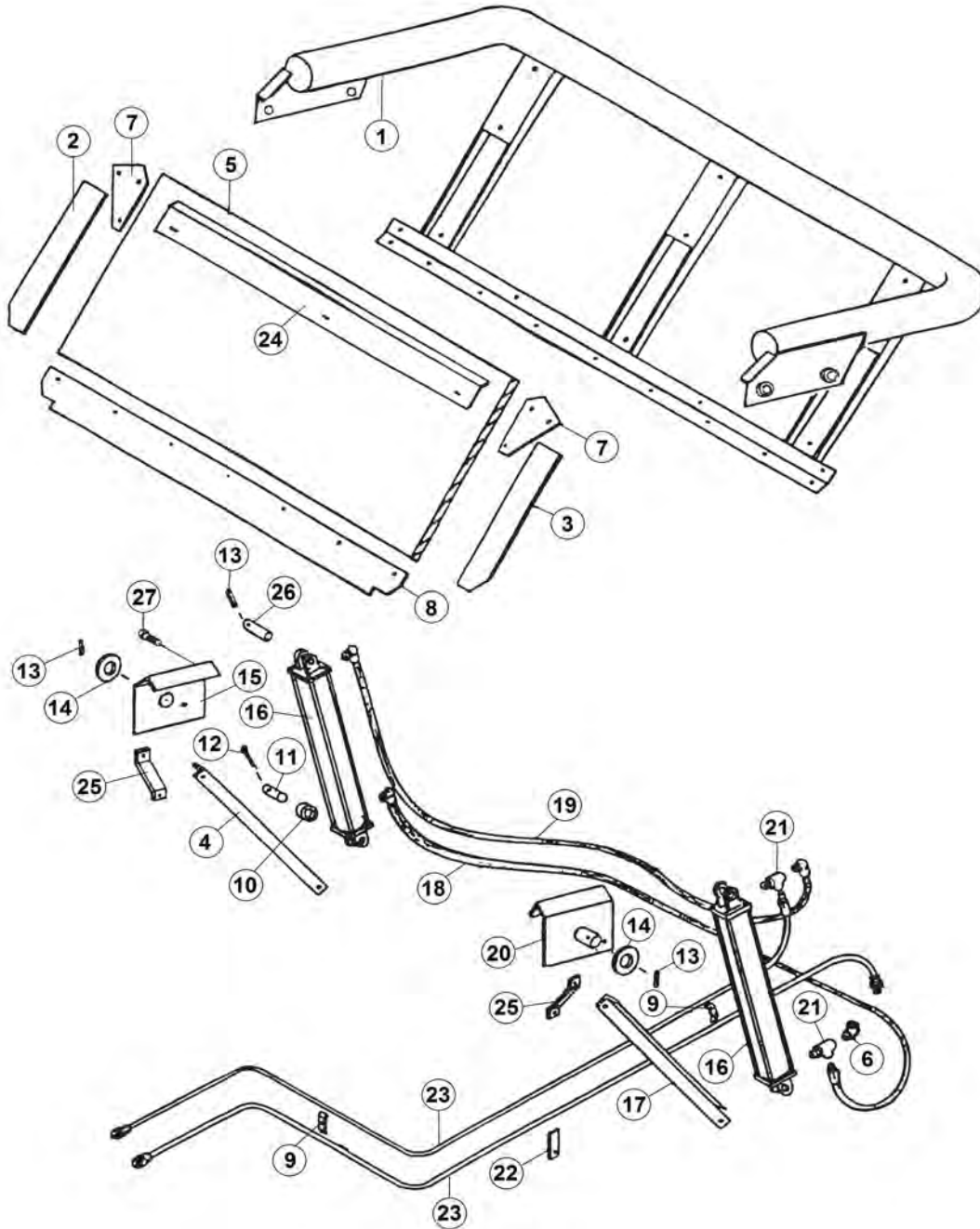

# FIGURE 5

## HYDRAULIC ENDGATE ASSEMBLY

<u>ITEM</u>	<u>PART #</u>	<u>DESCRIPTION</u>
1	23N298	TAILGATE FRAME
2	23N99	RH SIDE RUBBER
3	23N100	LH SIDE RUBBER
4	23N233	TAILGATE BRACKET BRACE
5	23N274A	TAILGATE PLYWOOD WITH FIBERGLASS
6	23N234	90° STREET ELBOW 3/8"
7	23N104	TAILGATE CORNER
8	23N105	BOTTOM RUBBER
9	23N67	HOSE BRACKET
10	K132	SPACER
11	23N107	CYLINDER PIN
12	YPCT07005	COTTER PIN, 7/32" X 2 "
13	YPEX10015	EXPANSION PIN, 5/16" X 1-3/4"
14	23N109	WASHER
15	23N299	RH TAILGATE MOUNT
16	23N111A	HYDRAULIC CYLINDER
*	56015	2" X 16" HYDRAULIC CYLINDER
17	23N231	BRACE
18	23N113	HOSE (96")
19	23N114	HOSE (138")
20	23N300	LH TAILGATE MOUNT
21	23N116	TEE
22	23N117	HOSE HOLDER
23	23N307	HOSE (23N307 - 274" / 27N47 - 298")
24	23N163	TAILGATE POLY HOLD DOWN
25	23N232	TAILGATE BRACKET BRACE CYLINDER
26	23N301	PIN
27	YBCR16021	1/2 X 1-3/4" GRADE 5 CARRIAGE BOLT

# FIGURE 6

## APRON CHAIN ASSEMBLY

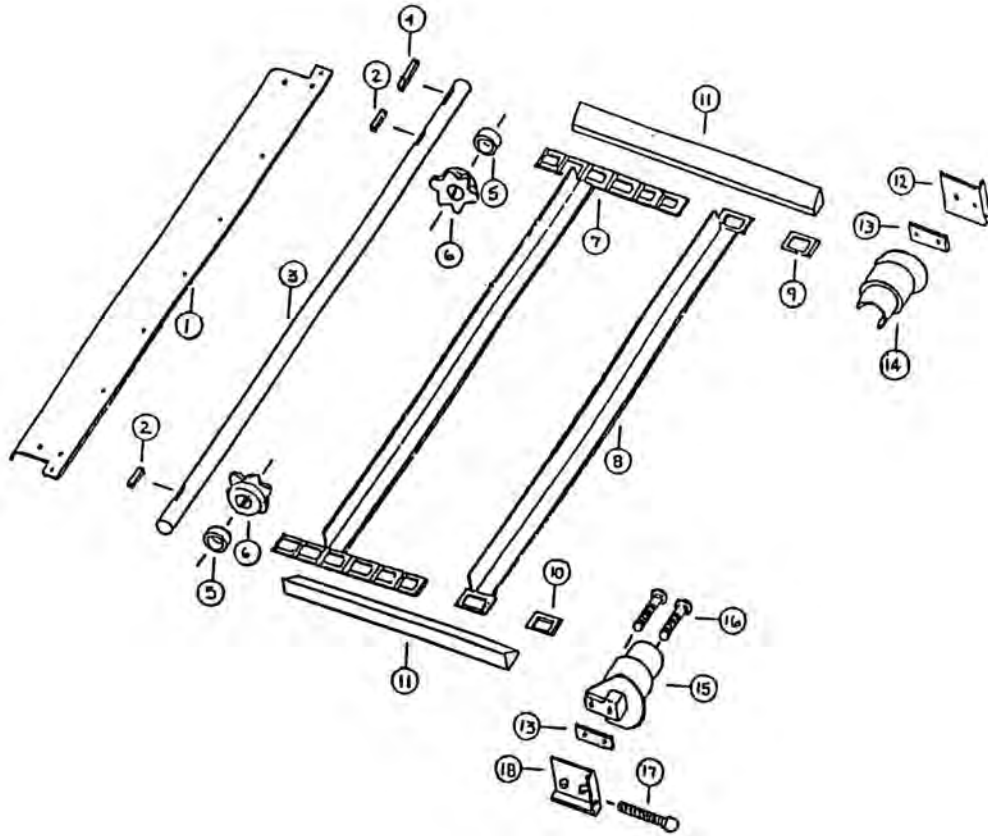

<u>ITEM</u>	<u>PART #</u>	<u>DESCRIPTION</u>
1	23N119	REAR POLY HOLD DOWN
2	23N303	3/8" X 1-3/4" SQUARE KEY
3	27N35	DRIVE SHAFT
4	A32	3/8" X 1-3/8" SQUARE KEY W/ ROUND ENDS
5	23N121	SPACER
6	23N122	DRIVE SPROCKET 6T
7	23N123	APRON CHAIN 17 SLATS, 210 LINKS
*	27N20	APRON CHAIN 20 SLATS, 244 LINKS
8	23N124	SLAT W/ ATTACHMENT LINK
9	S55	T-ROD STANDARD LINK
10	S56	T-ROD CHAIN SIDE SPACERS
11	23N125	APRON CHAIN SIDE SPACERS
12	A30	CHAIN SLIDE PLATE
13	23N126	CHAIN SLIDE SPACER
14	23N127	T-ROD SLIDE LH
15	23N128	T-ROD SLIDE RH
16	YBCR16045	CARRIAGE BOLT, 1/2" X 4" GR. 5
17	YBHH16140	BOLT, 1/2" X 4-1/2" GR. 5
18	A29	CHAIN SLIDE PLATE

\* MEANS NOT SHOWN

# FIGURE 7

## HYDRAULIC ENDGATE CYLINDER

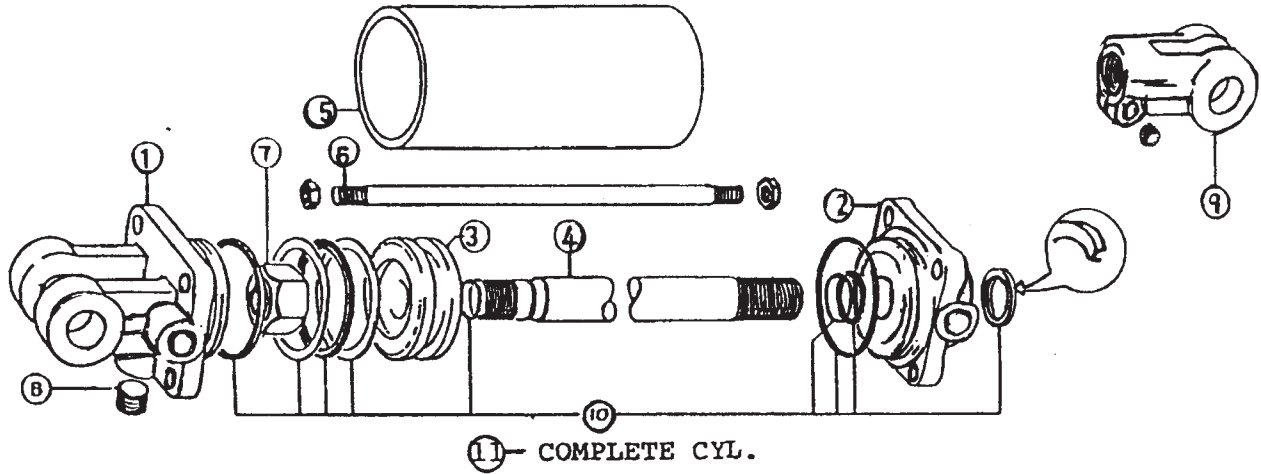

<u>ITEM</u>	<u>PART #</u>	<u>DESCRIPTION</u>
1	23N142A	CLEVIS CAP
2	23N143A	ROD CAP
*	56174	ROD CAP
3	23N144	PISTON
*	56180	PISTON
4	23N145A	ROD
5	23N146	CYLINDER TUBE
6	23N147	TIE ROD
7	23N148	PISTON NUT
8	23N149	PLUG
9	23N150A	ROD CLEVIS
10	23N151	SEAL KIT
*	56187	SEAL KIT
11	23N111A	HYDRAULIC CYLINDER COMPLETE
*	56015	HYDRAULIC CYLINDER COMPLETE

\* MEANS NOT SHOWN

# FIGURE 8

## PTO ASSEMBLY

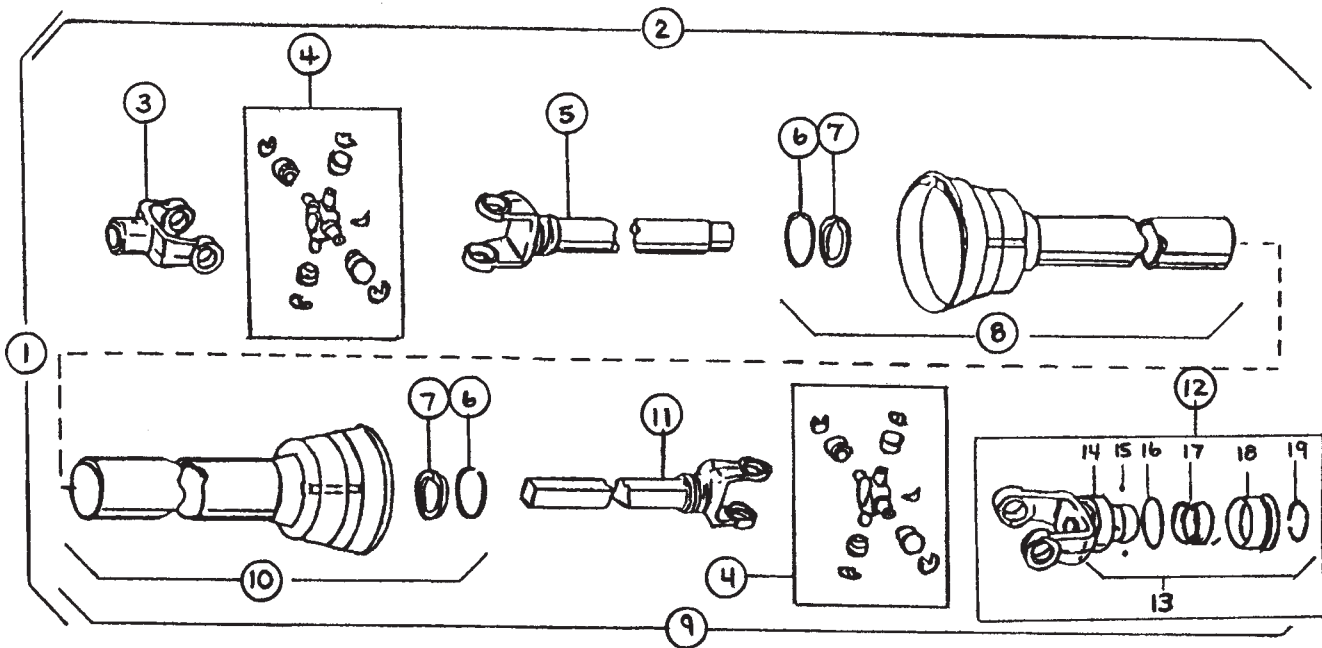

<u>ITEM</u>	<u>PART #</u>	<u>DESCRIPTION</u>
1	23N152	PTO ASSEMBLY COMPLETE W/ SHIELDS
2	23N153	MACHINE HALF PTO W/ SHIELD
3	G1R35	END YOKE MACHINE HALF
4	14NWKIT	REPAIR KIT
5	23N155	YOKE AND TUBE
6	24N26	BEARING RETAINER
7	4N20	NYLON BEARING
8	23N156	INNER GUARD INCLUDING ITEM #6 & #7
9	23N157	TRACTOR HALF PTO W/ SHIELD
10	23N158	OUTER GUARD INCLUDING ITEM #6 & #7
11	23N159	YOKE AND SHAFT
12	23N162	LOCK YOKE ASSEMBLY
13	S225	SPRING LOCK REPAIR KIT
14	S226	COVER
15	S212	STAINLESS BALL
16	S227	WASHER
17	S228	SPRING
18	S229	COLLAR ASSEMBLY
19	S215	RETAINING RING
*	S402	PTO SAFETY MANUAL

\* MEANS NOT SHOWN



# FIGURE 9

## OPTIONAL 2ND BEATER

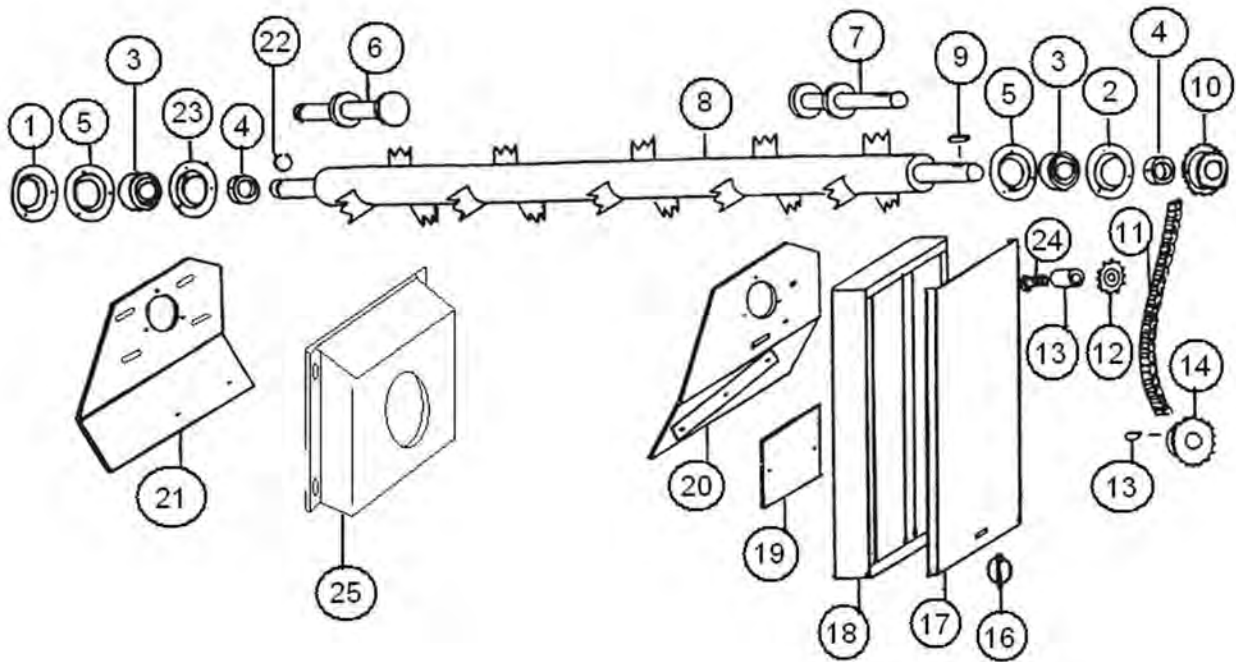

<u>ITEM</u>	<u>PART #</u>	<u>DESCRIPTION</u>
1	23N308	BEARING FLANGE GUARD
2	F114A	BEARING FLANGE W/ ZERK - 45°
3	12N122	BEARING W/ LOCK COLLAR ASSY.
4	12N122	BEARING W/ LOCK COLLAR ASSY.
5	F14	BEARING FLANGE
6	23N164	LH STUB SHAFT
7	23N165	RH STUB SHAFT
8	23N166	2ND BEATER
9	G23	5/16" X 1-3/8" SQUARE KEY
10	D18	16T SPROCKET
11	23N167	#60 CHAING (81 PITCHES)
12	12N42	IDLER SPROCKET
13	23N168	SPACER
14	F13	20T SPROCKET
15	5B9	3/8" X 1-1/4" WOODRUFF KEY
16	YPLY08010	LYNCH PIN, 1/4" X 1-1/2"
17	23N169	COVER
18	23N170	SHIELD
19	23N171	SHIELD
20	23N172	RH PANEL
21	23N173	LH PANEL
22	F73	SNAP RING
23	F114A	FLANGE W/ STRAIGHT ZERK
24	YBCR16040	CARR. BOLT, 1/2" X 3-1/2" GR. 5
25	57216	BEATER BEARING PROTECTOR

# FIGURE 10

## GEARBOX

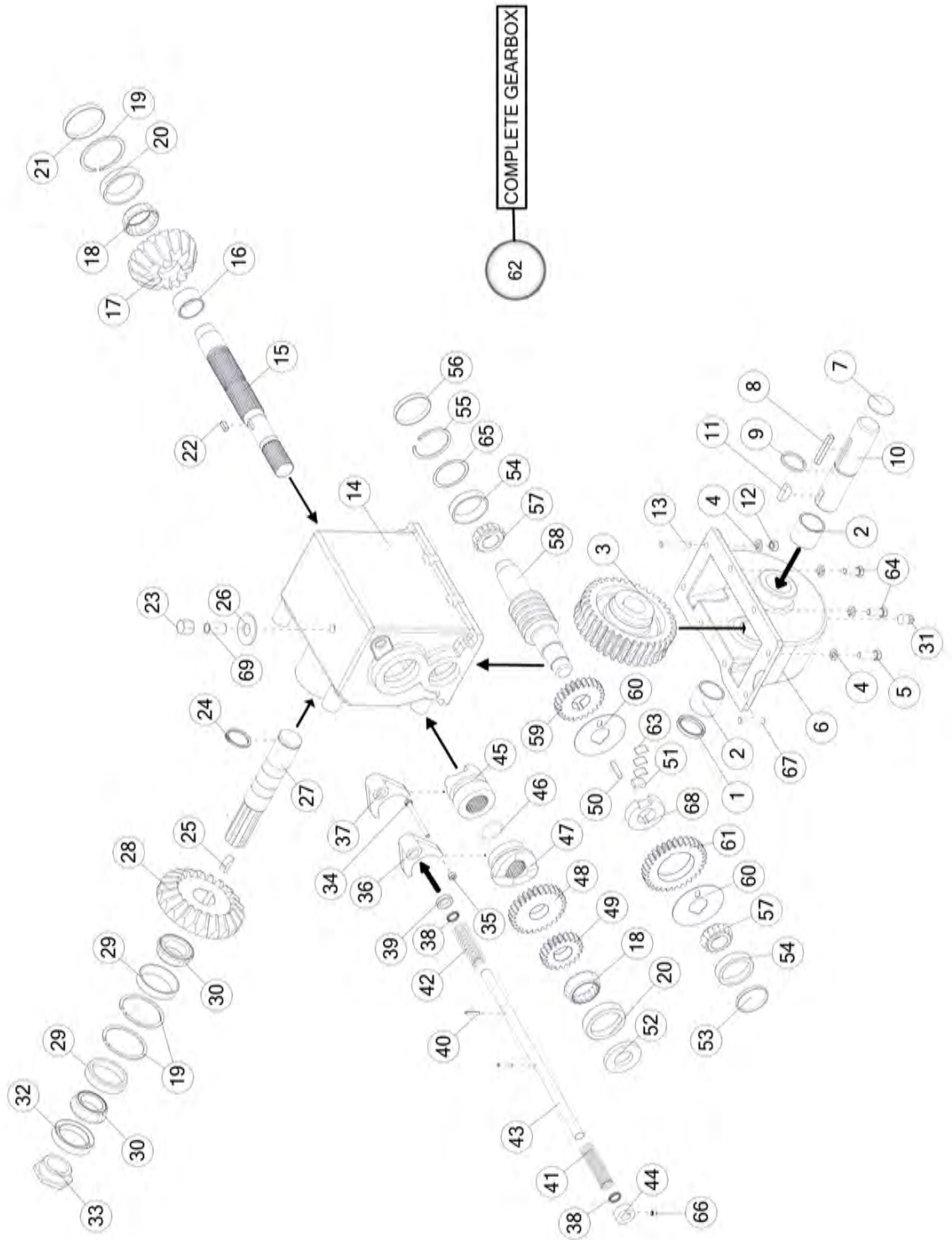

## **FIGURE 10**

### **GEARBOX**

<b><u>ITEM</u></b>	<b><u>QTY</u></b>	<b><u>PART #</u></b>	<b><u>DESCRIPTION</u></b>
1	1	17G133	SEAL, 1.88 X 1.50 X 0.25
2	2	17G134	BSH, 1.75 X 1.50 X 1.50, BRZ
3	1	17G137	GEAR, WORM, 36T, 6 PITCH, 2 SPEED GEAR BOX
4	8	YWLO12005	WASHER, LOCK, 3/8
5	2	YBHH12035	BOLT, HEX, 3/8-16 X 1-1/4, G5, ZC
6	1	17G107	CAST, HSG, GRBX, LOWER
7	1	17G139	CAP, 1.75
8	1	17G132	KEY, SQ, 0.31 X 0.31 X 2.25
9	1	17G135	SNAP RING, 1.424 ID X .125 WT
10	1	17G136	SHAFT, RND, 1.50, 7.093, WORM GEAR OUTPUT
11	1	5B9	KEY, WDF, 0.38 X 0.53 X 1.25
12	2	YNHX12005	HEX NUT, 3/8-16 GR 2
13	2	17G140	SCR, STUD, 0.38-16 X 1.81
14	1	17G99	CAST, HSG, GRBX, UPPER
15	1	17G108A	SHAFT, RND, 1.75, 12.82, PTO INPUT
16	1	17G111	BSH, 1.75 X 1.5 X 1.0, BRZ
17	1	17G110	GEAR, BEVEL, 16T, WITH 4 JAW
18	2	G18	BRG, 2.24 X 1.58 X .82, TAPER
19	3	G55	RING, SNAP, INTERNAL, 3.02 X 2.64
20	2	18VB25	BEARING, ROLL, CUP, 2.72,
21	1	G68	CAP, 2.72
22	1	17G116	KEY, SQ, 0.25 X 0.25 X 0.63
23	1	17G58	VENT CAP
24	1	12V62	HEAVY DUTY EXTERNAL SNAP RING, 1.50" KEY,
25	1	G61	WDF, 0.38 X 0.55 X 1.25
26	1	YWFL24005	WASHER, FLAT, 3/4 IN USS
27	1	17G104	SHAFT, RND, 1.50, 9.0, BEATER OUTPUT GEAR,
28	1	17G101	BEVEL, 22T
29	2	17G102	BEARING, ROLL, CUP, 2.72,
30	2	17G103	BRG, 2.35 X 1.50 X 0.75, TAPER
31	1	G65	PLUG, PIPE 3/8-18 NPT



# **FIGURE 10**

## **GEARBOX**

<b><u>ITEM</u></b>	<b><u>QTY</u></b>	<b><u>PART #</u></b>	<b><u>DESCRIPTION</u></b>
32	1	17G105	SEAL, 2.72 BORE, 2.00 SHAFT
33	1	17G106	NUT, HEX, 1.50-18, NA
34	1	YBHH08090	BOLT, 1/4 X 3 GR 2 FULL THREAD
35	1	YNHX08007	HEX NUT, 1/4-20 GR 5
36	1	17G125	YOKE, SHIFTER, HIGH SPEED
37	1	17G129	YOKE, SHIFTER, BEATER
38	2	17G121	SEAL, .813 BORE X .625 SHAFT
39	1	17G122	TUBE, RND, STR, 1.06 X 0.14 X 0.25
40	2	17G123	PIN, ROLL, 0.19 X 1.0, ZN
41	1	17G128	SPRG, COIL, 3.36, COMP
42	1	17G130	SPRG, COIL, 3.13, COMP
43	1	17G131	SHAFT, RND, 0.625, 15.0, SHIFTER ROD
44	1	17G171	COLLAR, LOCK, 1.25X.629,
45	1	17G109	BEATER CLUTCH, 2 SPEED GEAR BOX
46	1	17G169A	RING, SNAP, 1.57 X 1.38
47	1	17G119	HIGH SPEED CLUTCH, 2 JAW
48	1	17G118	GEAR, 28T, HIGH SPEED W/2 JAWS GEAR,
49	1	17G115	LOW SPEED, 2 SPEED GEAR BOX
50	1	S135	KEY, SQ, 0.25X0.25X1.25
51	1	17G124	KEY, 0.75 X 0.25 X 0.56
52	1	S136	SEAL, OIL, 1.25 ID X 2.44 OD X .31 THK
53	1	17G100	CAP, 2.14
54	2	3G18	BEARING, ROLL, CUP, 2.54,
55	1	3G19	RING, SNAP, INTERNAL, 2.59 X 2.22
56	1	G90	CAP
57	2	L3G24	BRG, 1.75 X 1.13 X 0.81, TAPER
58	1	17G120	SHAFT, RND, 2.33, 9.84
59	1	17G117	GEAR, HIGH SPEED, 2 SPEED GEARBOX
60	2	17G112	WASH, FLAT, 3.50, 1.26
61	1	17G113	LOW SPEED GEAR, 2 SPEED GEARBOX
62	1	17G142	ASSM, 2 SPEED GEARBOX
63	3	17G126	SPRG, DOG, 0.552 X 0.75
64	4	YBHH12010	BOLT, HEX, 3/8-16 X 1, G5, ZC
65	1	G92	SHIM, STAINLESS, 2.40" OD X 2.00" ID, X .010
66	1	YSKP10015	SET SCREW, SOCKET, KNURLED CUP PT, 5/16 X 5/16
67	1	17G138	SCR, STUD, 0.38-16 X 2.0
68	1	17G114	CLUTCH, LOW SPEED, 2 SPEED GEARBOX
69	1	23N288	PIPE NIPPLE, 0.38 X 1.25

**FIGURE 11**  
**4-HOSE HYDRAULIC DRIVE**

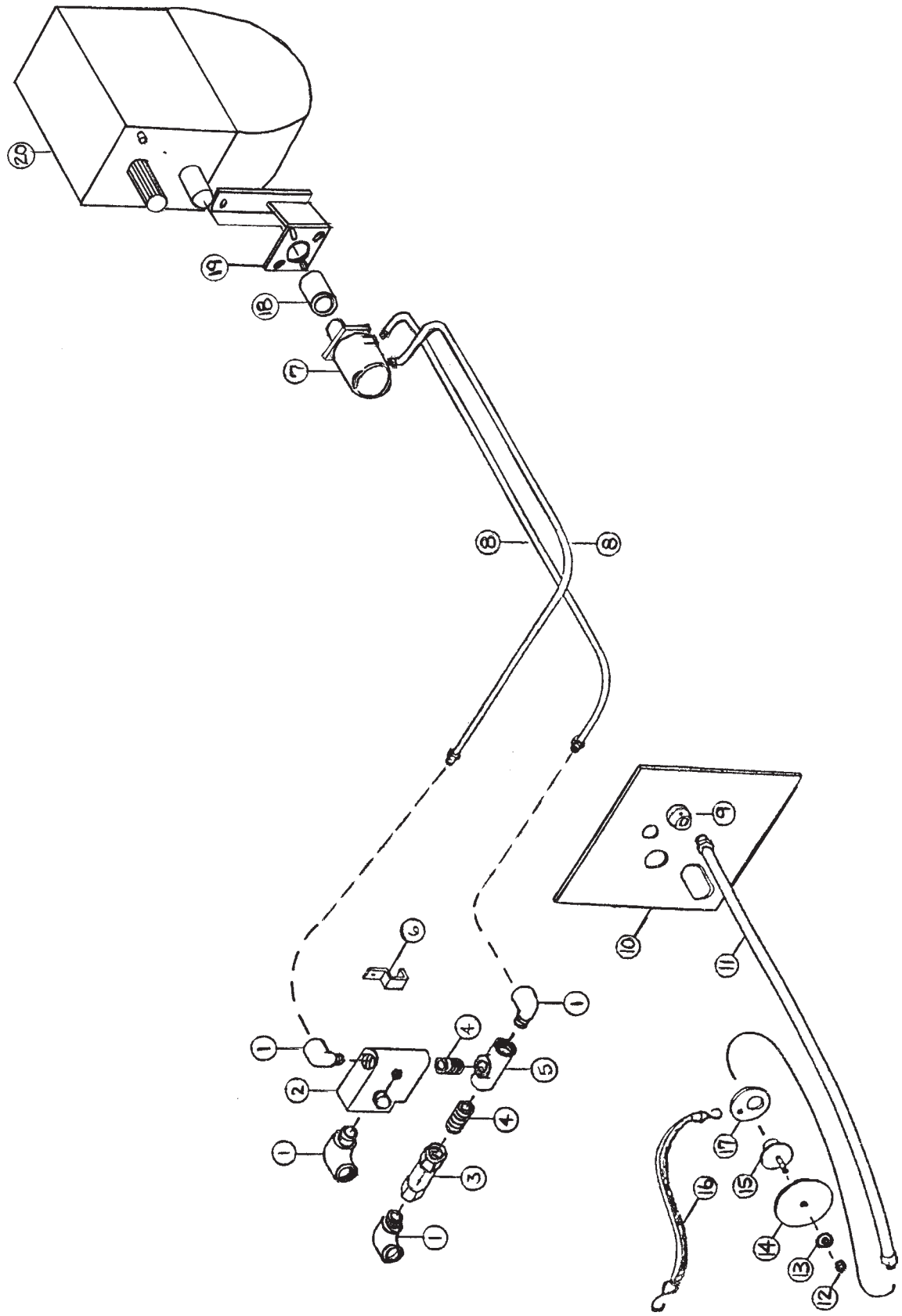



**FIGURE 11**  
**4-HOSE HYDRAULIC DRIVE**

<b><u>ITEM</u></b>	<b><u>PART #</u></b>	<b><u>DESCRIPTION</u></b>
1	HE58	90 DEGREE STREET ELBOW
2	DF15	SPEED CONTROL
3	DF18	CHECK VALVE
4	DF7	NIPPLE
5	DF8	TEE
6	HE14	HOSE BRACKET
7	DF1	HYDRAULIC MOTOR
8	23N132	HYDRAULIC MOTOR HOSE
9	DF21	REDUCER
10	23N133	CONTROL PANEL
11	DF9	HOSE FOR HANDLE
12	YNTL12005	HEX NUT, TOP LOCK, 3/8"-16
13	DF12	WASHER
14	DF11	HANDLE
15	DF10	HANDLE BRACKET
16	DF14	STRAP
17	DF22	RING FOR STRAP
18	17G161	COUPLER
19	17G162	MOUNTING BRACKET
20	17G163	COMPLETE GEARBOX

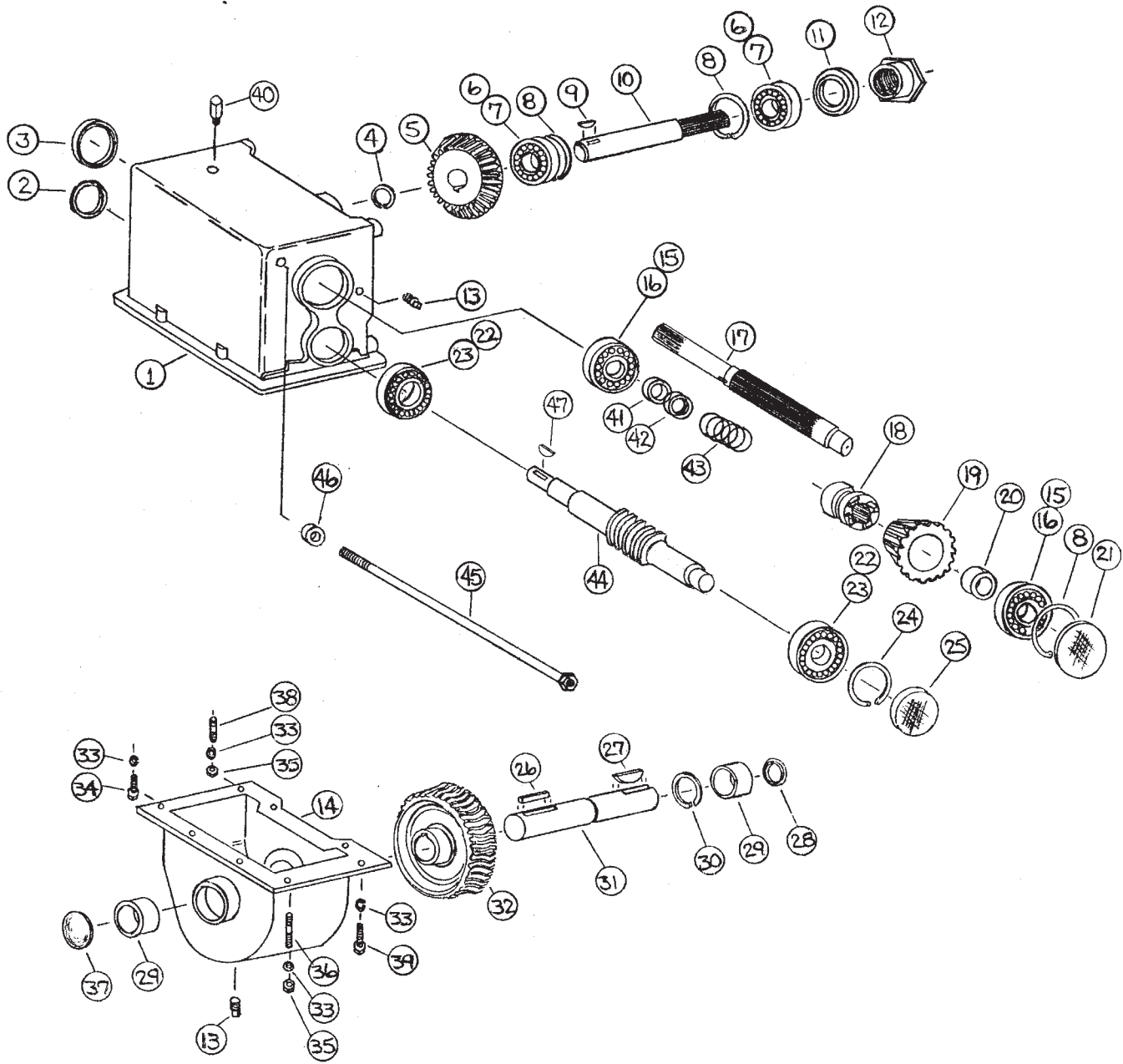

**FIGURE 12**  
**2-HOSE HYDRAULIC DRIVE**

<b><u>ITEM</u></b>	<b><u>PART #</u></b>	<b><u>DESCRIPTION</u></b>
1	17G163	COMPLETE GEARBOX
2	17G162	MOUNTING BRACKET
3	17G161	COUPLER
4	DF1	HYDRAULIC MOTOR
5	23N132	HYDRAULIC MOTOR HOSE
6	DF21	REDUCER
7	23N133	CONTROL PANEL
8	DF9	HOSE FOR HANDLE
9	YNTL12005	HEX NUT, TOP LOCK, 3/8"-16
10	DF12	WASHER
11	DF11	HANDLE
12	DF10	HANDLE BRACKET
13	DF22	RING FOR STRAP
14	DF14	STRAP
15	DF6	SEQUENCE VALVE
16	DF7	NIPPLE
17	DF8	TEE
18	HE14	HOSE BRACKET
19	DF18	CHECK VALVE
20	DF19	TEE
21	DF17	NIPPLE
22	DF15	SPEED CONTROL
23	DF16	DRAIN HOSE
24	HE58	90 DEGREE STREET ELBOW

# FIGURE 13

## HYDRAULIC DRIVE GEARBOX



## **FIGURE 13**

### **HYDRAULIC DRIVE GEARBOX**

<b><u>ITEM</u></b>	<b><u>PART #</u></b>	<b><u>DESCRIPTION</u></b>
1	17G99	UPPER GEAR HOUSING
2	17G164	SEAL
3	S136	SEAL
4	12V62	RETAINING RING
5	17G101	22T BEVELED GEAR
6	17G102	RACE 13621
7	17G103	BEARING 13685
8	G55	RETAINING RING
9	G61	3/8" X 1-1/4" HARDENED WOODRUFF KEY
10	17G104	BEATER OUTPUT SHAFT
11	17G105	SEAL
12	17G106	ADJUSTMENT NUT
13	G65	PLUG
14	17G107	LOWER GEAR HOUSING
15	G54	RACE 14276
16	G18	BEARING 14124
17	17G108A	INPUT SHAFT
18	17G109	BEATER CLUTCH
19	17G110	16T BEVELED GEAR W/ CLUTCH
20	17G111	BUSHING 1-1/2" ID X 1" LENGTH
21	G68	CAP
22	3G18	RACE 15245
23	L3G24	BEARING 15113
24	3G19	RETAINING RING
25	G90	CAP
26	17G132	5/16" X 2-1/4" KEY
27	5B9	3/8" X 1-1/4" WOODRUFF KEY
28	17G133	SEAL
29	17G134	BUSHING 1-1/2" ID X 1-1/2" LENGTH
30	17G135	RETAINING RING
31	17G136	WORM GEAR OUTPUT SHAFT
32	17G137	WORM GEAR
33	YWLO12005	WASHER, LOCK, 3/8"
34	YBHH12010	BOLT, 3/8" X 1" GR. 5
35	YNHX12005	HEX NUT, 3/8"-16
36	17G138	3/8" X 2" STUD
37	17G139	1-3/4" CAP
38	17G140	3/8" X 1-1/2" STUD
39	YBHH12035	BOLT, 3/8" X 1-1/4" GR. 5
40	G24	VENT PIPE PLUG
41	17G165	5/8" SPACER
42	A25	1" SPACER
43	23N89	CLUTCH SPRING
44	17G166	WORM SHAFT
45	17G167	BOLT
46	17G168	3/4" SPACER
47	5B10	1/4" X 1" KEY







# H&S MFG. CO.

products approved

for the

## FEMA

# SEAL OF QUALITY

