

H&S

PARTS BOOK

HP4142 SPREADER



Revision #04

Starting Serial:

HPH4142 - 811HP42001

HPV4142 - 811VP42001

Part #72478

HSMFG0518

2608 S. HUME AVE. , MARSHFIELD, WI 54449

(715) 387-3414 FAX (715) 384-5463

www.hsmfgco.com

CONTENTS

Instructions for Ordering Parts	1
Figure 1 - Frame Assembly	2-5
Figure 2 - Tandem Axle	6-9
Figure 3 - Beater Drive Train	10-13
Figure 4 - Endgate	14-15
Figure 5 - Beaters	16-19
Figure 6 - Pusher	20-23
Figure 7 - Pusher and Endgate hyd. Components	24-27
Figure 8 - Endgate Cylinder	28-29
Figure 9 - Hydraulic Pusher Cylinder	30-31
Figure 10 - Beater Gearbox	32-33
Figure 11 - Vertical Beater Frame	34-37
Figure 12 - Vertical Beater Drive Train	38-41
Figure 13 - Superior Gearbox Left	42
Figure 14 - Superior Gearbox Right	43
Figure 15 - Chain Oiler	44-45
Figure 16 - Optional Lighting	46
Figure 17 - Optional Rear Pan	47
Figure 18 - 1-3/8 540 Rpm Clutched Pto Option	48
Figure 19 - 1-3/8 1000 Rpm Clutched Pto Option	49
Figure 20 - 1-3/4 1000 Rpm Clutched Pto Option	50
Figure 21 - 1-3/8 1000 Rpm Shear Bolt Pto Option	51
Figure 22 - 1-3/4 1000 Rpm Shear Bolt Pto Option	51
Notes	52

INSTRUCTIONS FOR ORDERING PARTS

All service parts should be ordered through your authorized H&S dealer. He will be able to give you faster service if you will provide them with the following:

1. Model & Serial Number - Both can be located on the side of the center bearing post above jack mount.
2. All references to left or right apply to the machine as viewed from the rear.
3. Parts should not be ordered from illustration only. Please order complete part number.
4. If your dealer has to order parts - give shipping instructions:

VIA truck - large pieces (please specify local truck lines)

VIA United Parcel Service (include full address)

H&S MFG. CO. INC.	
MARSHFIELD, WIS.	
MOD. NO.	<input type="text"/>
SER. NO.	<input type="text"/>
DESCR.	<input type="text"/>

PLEASE RECORD NUMBERS FOR YOUR UNIT FOR QUICK REFERENCE

ABOUT IMPROVEMENTS

H&S IS CONTINUALLY STRIVING TO IMPROVE IT'S PRODUCTS

We must therefore, reserve the right to make improvements or changes whenever it becomes practical to do so, without incurring any obligation to make changes or additions to the equipment previously sold.

FIGURE 1

FRAME ASSEMBLY

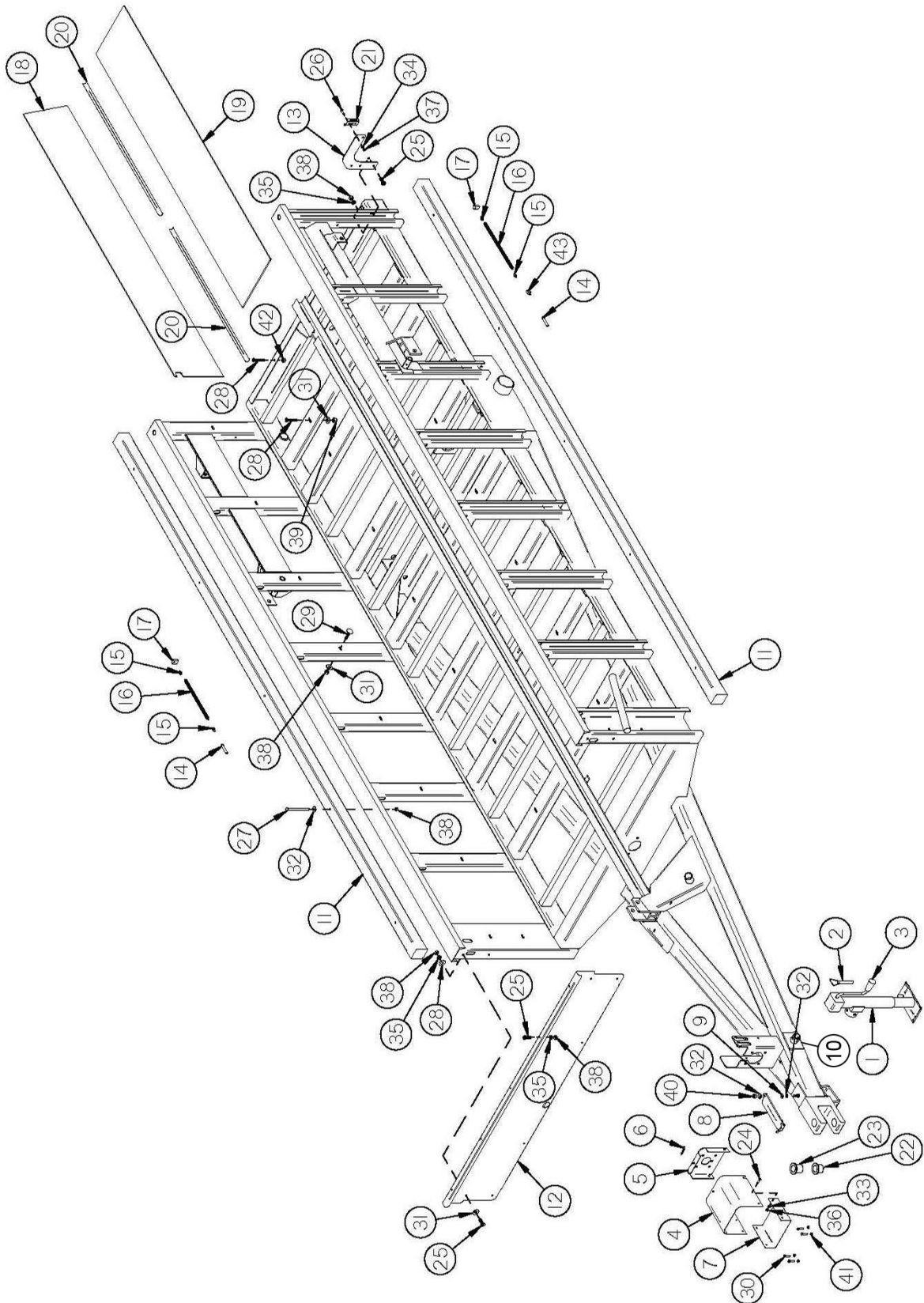

FIGURE 1

FRAME ASSEMBLY

<u>ITEM</u>	<u>QTY</u>	<u>PART #</u>	<u>DESCRIPTION</u>
1	1	27N49	JACK
2	1	27N50	PIN & CHAIN, 5/8"
3	1	12N119	JACK HANDLE
4	1	16SV329	PTO SHIELD
5	1	42N1	SHIELD MOUNT
*	2	YMRV10005	RIVET, FLAT HEAD, 5/16" X 1 SLD NAIL
6	1	YPHR02005	HAIR PIN
7	1	16SV327	SHIELD BOTTOM
8	1	42N2	PTO HOLDER
9	1	42N3	SPRING
10	1	12N121	JACK MOUNT
11	2	42N4	WOOD RAIL
12	1	42N5	FRONT PANEL
13	1	42N43	SMV BRACKET
14	2	66077	NIPPLE, 1/8 MALE PIPE X 2-1/2
15	4	S47	GREASE FITTING
16	2	42N41	GREASE LINE
17	2	16V9	GREASE BRACKET
18	1	42N8	SIDE POLY RH
*	1	42N9	SIDE POLY LH
19	1	42N10	FLOOR POLY RH
*	1	42N11	FLOOR POLY LH

NOTE: * MEANS NOT SHOWN

FIGURE 1

FRAME ASSEMBLY

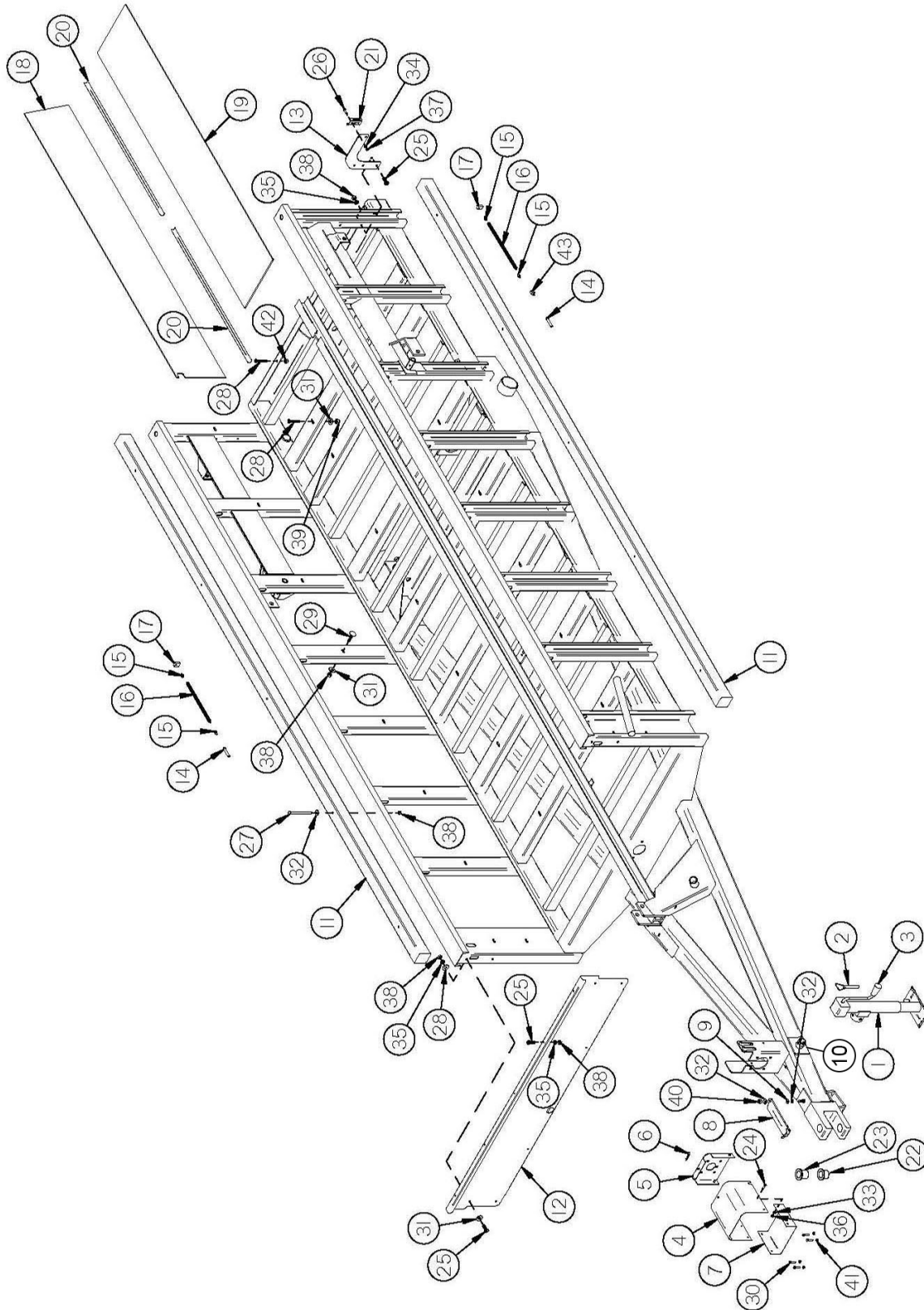

FIGURE 1

FRAME ASSEMBLY

<u>ITEM</u>	<u>QTY</u>	<u>PART#</u>	<u>DESCRIPTION</u>
20	4	42N12	POLY SIDE ANGLE
21	1	F97	SMV HOLDER
22	1	42N166	HITCH PIN BUSHING BOTTOM (OPTIONAL)
23	1	42N167	HITCH PIN BUSHING TOP (OPTIONAL)
24	4	YBHH08010	BOLT HEX, 1/4 X 1 G5
25	11	YBHH12010	BOLT HEX, 3/8 X1 G5
26	2	YBCR10030	BOLT CARRIAGE, 5/16 X 3/4 G5
27	10	YBCR12105	BOLT CARRIAGE, 3/8 X 4-1/2 G5 FULL THREAD
28	20	YSFS12005	FLAT HEAD, SOCKET CAP SCREW, 3/8 X 1-1/4 G5
29	18	YBPL12010	FLAT HEAD PLOW BOLT, 3/8 X 1-1/4 G5
30	4	YBHH10070	BOLT HEX, SHEAR, 5/16 x 2 G5 (1000 RPM)
*	4	YBHH10075	BOLT HEX, SHEAR, 5/16 x 2 G8 (540 RPM)
31	40	YWFL12005	WASHER FLAT, 3/8 USS
32	12	YWFL14005	WASHER FLAT, 7/16 USS
33	4	YWLO08005	WASHER LOCK 1/4
34	2	YWLO10005	WASHER LOCK 5/16
35	11	YWLO12005	WASHER LOCK 3/8
36	4	YNHX08005	NUT HEX, 1/4
37	2	YNHX10005	NUT HEX, 5/16
38	39	YNHX12005	NUT HEX, 3/8
39	14	YNNY12005	NUT HEX, NYLON LOCKNUT, 3/8
40	1	YNNY16005	NUT HEX, NYLON LOCKNUT, 1/2
41	4	YNRL10005	NUT HEX, REVERSIBLE - SIDE LOCK, 5/16
42	6	YNTL12005	NUT HEX, TOP LOCK, 3/8
43	1	66079	HEX ADAPTER, 1/4 FEMALE & 1/8 FEMALE PIPE

NOTE: * MEANS NOT SHOWN

FIGURE 2

TANDEM AXLE

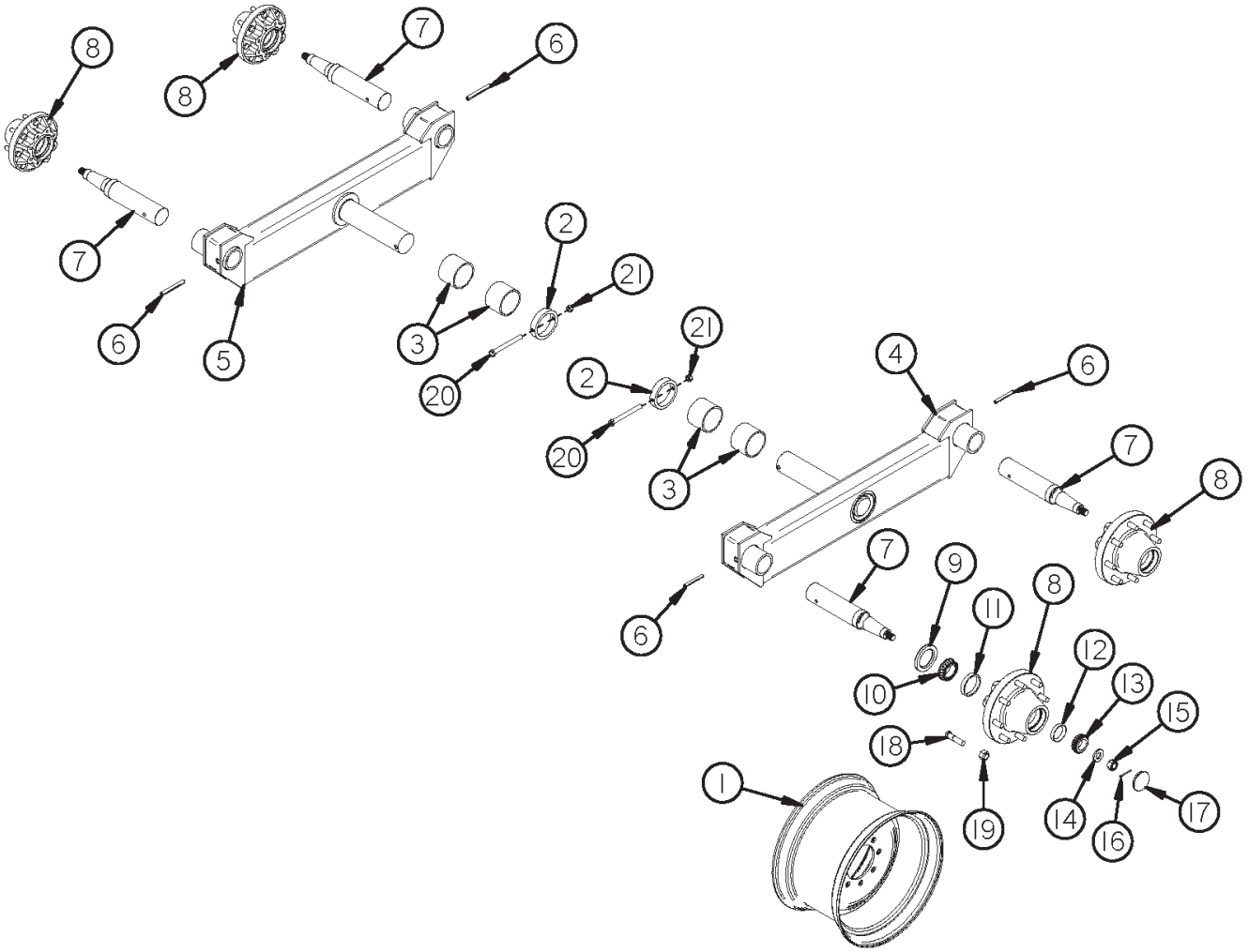

FIGURE 2

TANDEM AXLE

<u>ITEM</u>	<u>QTY</u>	<u>PART#</u>	<u>DESCRIPTION</u>
1	4	16SV89	WHEEL 13.5 X 22.5
*	4	42N138	TIRE (385 x 22.5 TRUCK)
OPT.	4	12N36	WHEEL 16.1 X 14 (8 Bolt)
OPT.	4	23N54	TIRE (16.5 X 16.1 FLOTATION)
2	2	45N35	COLLAR FOR AXLE
3	4	45N36	POLY BUSHING
4	1	42N6	TANDEM AXLE LH
5	1	42N7	TANDEM AXLE RH
6	4	YPEX16020	ROLL PIN
7	4	33SV40	SPINDLE
8	4	33SV45	HUB
*	4	RG275	HUB COMPLETE
9	4	33SV42	SEAL
10	4	33SV43	INNER BEARING
11	4	33SV44	INNER RACE
12	4	RG169	OUTER RACE
13	4	RG70	OUTER BEARING
14	4	33SV95	WASHER
15	4	YNSL32005	NUT HEX , SLOTTED, 1
16	4	YPCT06005	COTTER PIN
17	4	RG171	HUB CAP
18	32	YBSD20010	STUD BOLT, 5/8 UNF X 2-1/2 (7/8 SHOULDER)
19	32	YNWL24005	WHEEL NUT, 5/8 UNF
20	2	YBHH16160	BOLT HEX, 1/2 X 5-1/2 G5
21	2	YNNY16005	NUT HEX , NYLON LOCKNUT, 1/2

NOTE: * MEANS NOT SHOWN

FIGURE 3

BEATER DRIVE TRAIN

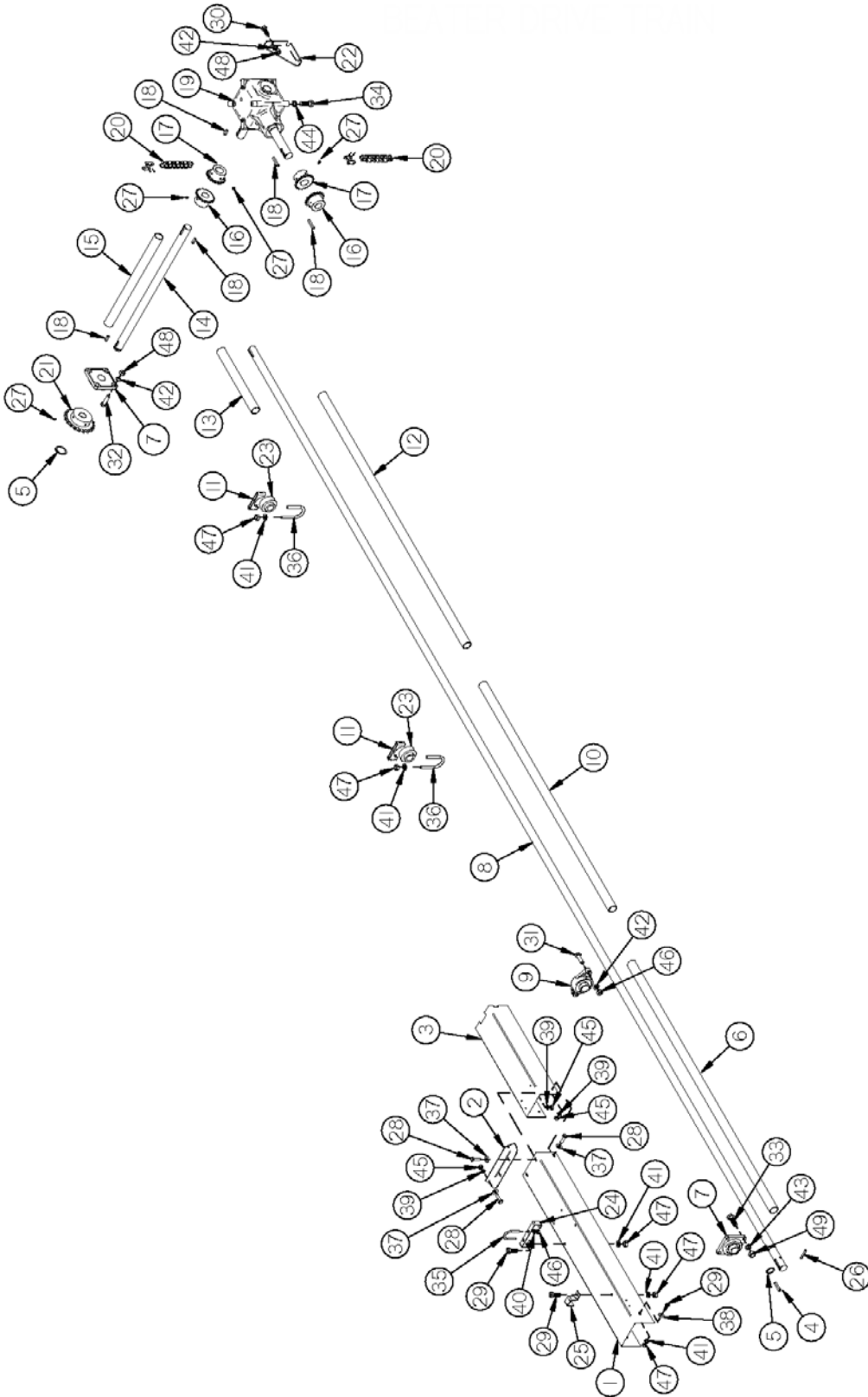

FIGURE 3

BEATER DRIVE TRAIN

<u>ITEM</u>	<u>QTY</u>	<u>PART #</u>	<u>DESCRIPTION</u>
1	1	42N13	INPUT SHAFT SHIELD
2	1	42N14	INPUT SHIELD ANGLE
3	1	42N15	INPUT SHIELD BACK
4	1	S138	KEY W/ ROUND ENDS, 3/8 X 2-3/8
5	2	12V62	SNAP RING
6	1	42N16	INPUT PVC SHIELD
7	2	12V99	BEARING
8	1	42N17	INPUT SHAFT
9	1	42N18	BEARING
10	1	42N19	DRIVE SHAFT CENTER PVC SHIELD
11	2	42N137	BEARING SADDLE
12	1	42N20	DRIVE SHAFT MIDDLE PVC SHIELD
13	1	42N21	DRIVE SHAFT BACK PVC SHIELD
14	1	56783	CROSS SHAFT
15	1	42N23	CROSS SHAFT PVC SHIELD
16	2	42N24	SPROCKET (50-B-20)
17	2	42N25	SPROCKET (50-B-20)
18	5	56N174	KEY W/ROUND ENDS, 3/8 X 2 (HARDENED)
19	1	42N26	GEARBOX
20	2	HGV124	CONNECTOR CHAIN (#50) (20P)
21	1	56769	OVER RUNNING CLUTCH
22	1	42N49	GEARBOX GUSSET
23	2	42N100	BEARING

FIGURE 3
BEATER DRIVE TRAIN

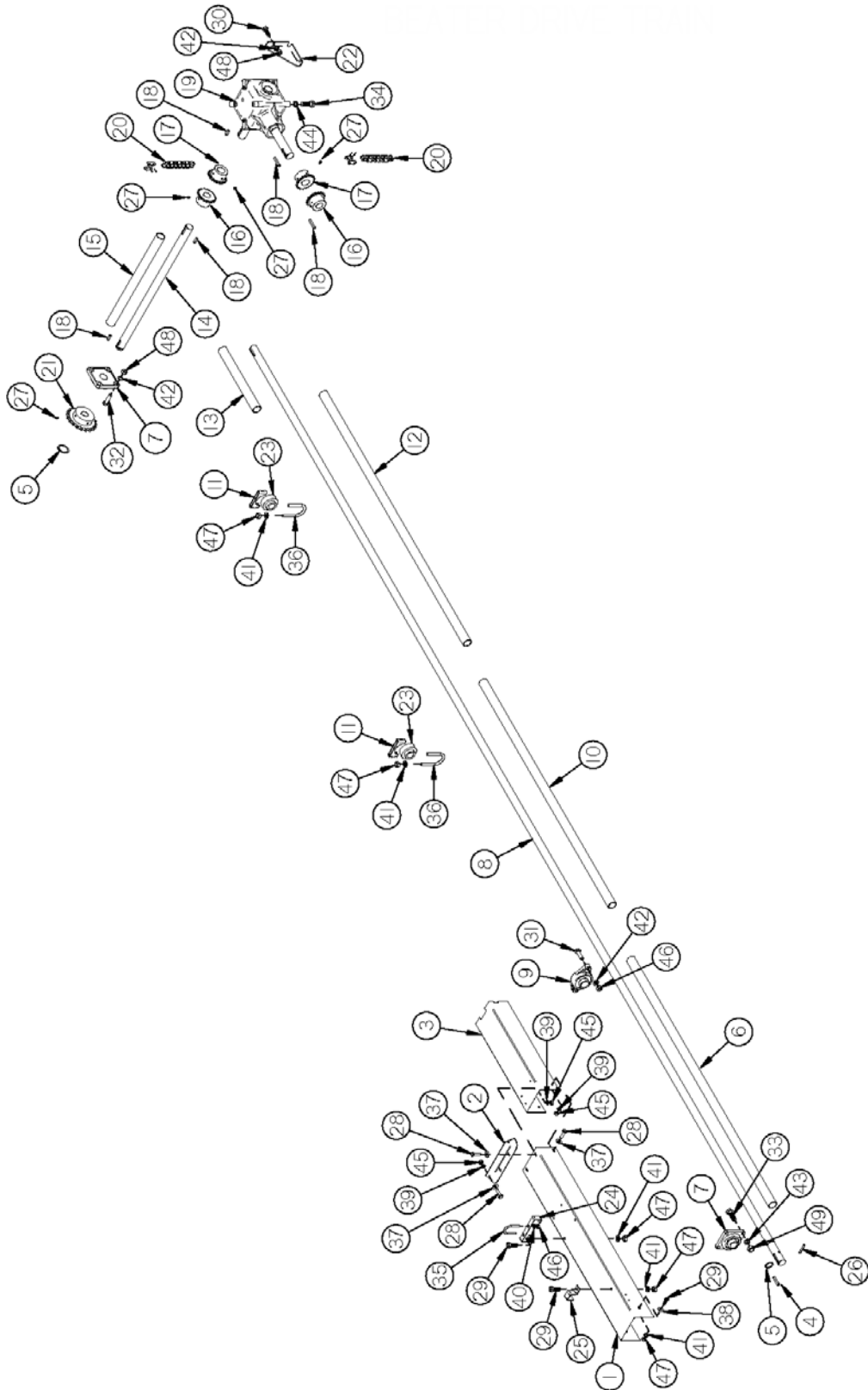

FIGURE 3

BEATER DRIVE TRAIN

<u>ITEM</u>	<u>QTY</u>	<u>PART#</u>	<u>DESCRIPTION</u>
24	1	42N101	HOSE HOLDER
25	1	HE14	SMALL PIPE BRACKET
26	1	YPEX12023	EXPANSION PIN, 3/8 X 2-1/2
27	10	YSKP12025	SET SCREW, SOCKET, KNURLED CUP PT, 3/8 X 3/8
28	6	YBHH08010	BOLT HEX, 1/4 X 1 G5
29	5	YBHH12010	BOLT HEX, 3/8 X 1 G5
30	2	YBHH16045	BOLT HEX, 1/2 X 1-1/4 G5
31	2	YBHH16030	BOLT HEX, 1/2 X 1-1/2 G5
32	4	YBHH16055	BOLT HEX, 1/2 X 1-3/4 G5
33	4	YBHH18015	BOLT HEX, 9/16 X 2 G5
34	4	YBHH20015	BOLT HEX, 5/8 X 1-1/4 G5
35	1	YBPU10007	PIPE U BOLT, 5/16 X 2
36	2	YBPU12025	U-BOLT, 3/8 X 3
37	6	YWFL08005	WASHER FLAT, 1/4 USS
38	2	YWFL12005	WASHER FLAT, 3/8 USS
39	6	YWLO08005	WASHER LOCK, 1/4
40	2	YWLO10005	WASHER LOCK, 5/16
41	5	YWLO12005	WASHER LOCK, 3/8
42	8	YWLO16005	WASHER LOCK, 1/2
43	4	YWLO18005	WASHER LOCK, 9/16
44	4	YWLO20005	WASHER LOCK, 5/8
45	6	YNHX08005	NUT HEX, 1/4
46	2	YNHX10005	NUT HEX, 5/16
47	5	YNHX12005	NUT HEX, 3/8
48	8	YNHX16005	NUT HEX, 1/2
49	4	YNHX18005	NUT HEX, 9/16

FIGURE 4
ENDGATE

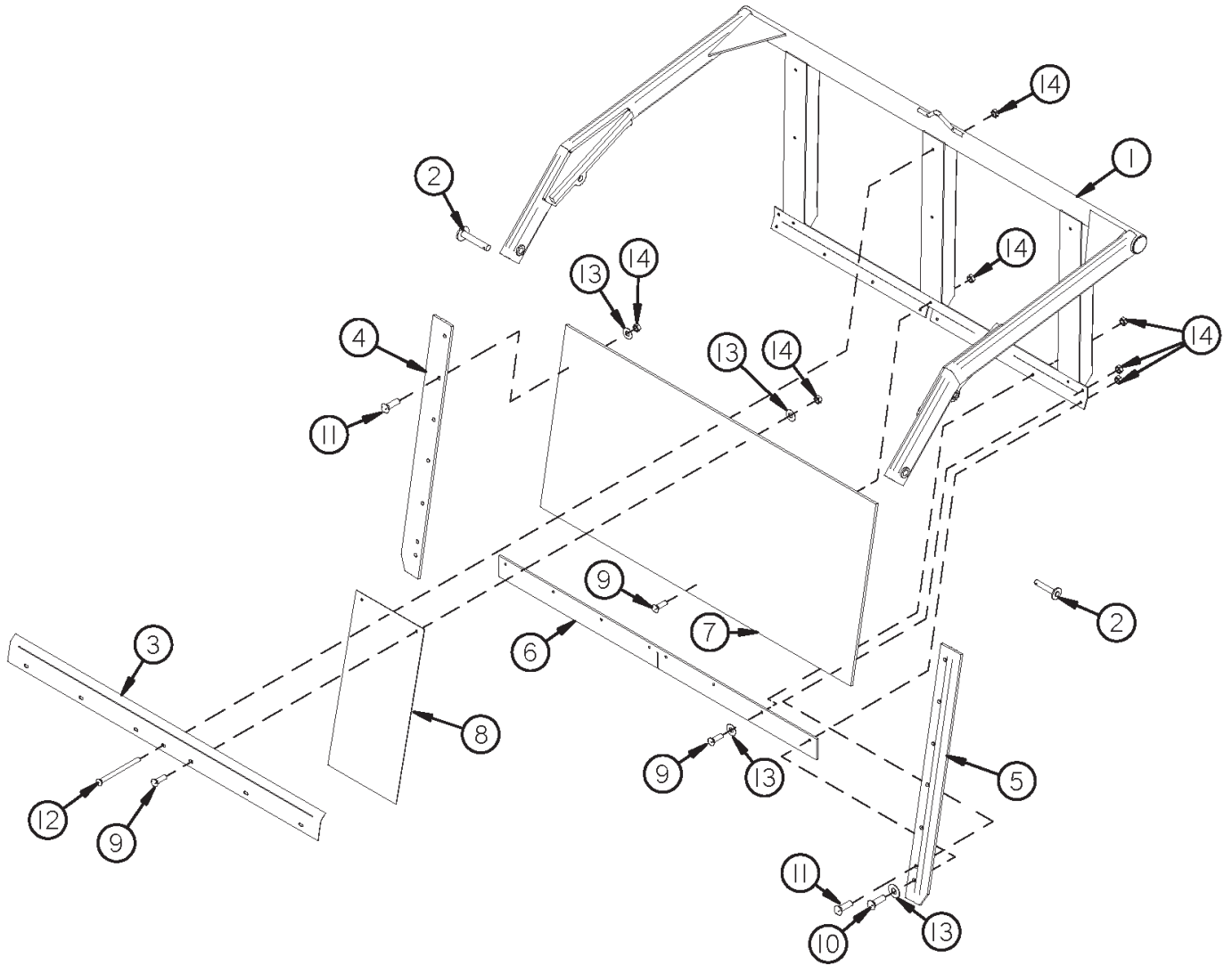

FIGURE 4

ENDGATE

<u>ITEM</u>	<u>QTY</u>	<u>PART #</u>	<u>DESCRIPTION</u>
1	1	42N28	ENDGATE
2	2	42N29	HINGE PIN
3	1	42N30	ENDGATE POLY HOLDOWN
4	1	42N31	ENDGATE RUBBER RH
5	1	42N32	ENDGATE RUBBER LH
6	1	42N33	ENDGATE RUBBER
7	1	42N34	ENDGATE POLY
8	5	42N165	ENDGATE CURTAIN
9	13	YBCR12010	BOLT CARRIAGE, 3/8 X 1 G5
10	2	YBCR12015	BOLT CARRIAGE, 3/8 X 1-1/2 G5
11	12	YBCR12030	BOLT CARRIAGE, 3/8 X 1-3/4 G5
12	6	YBCR12105	BOLT CARRIAGE, 3/8 X 4-1/2 GR G FULL THREAD
13	22	YWFL12005	WASHER FLAT, 3/8 USS
14	33	YNHX12005	NUT HEX , 3/8 G2

FIGURE 5

HORIZONTAL BEATER ASSEMBLY

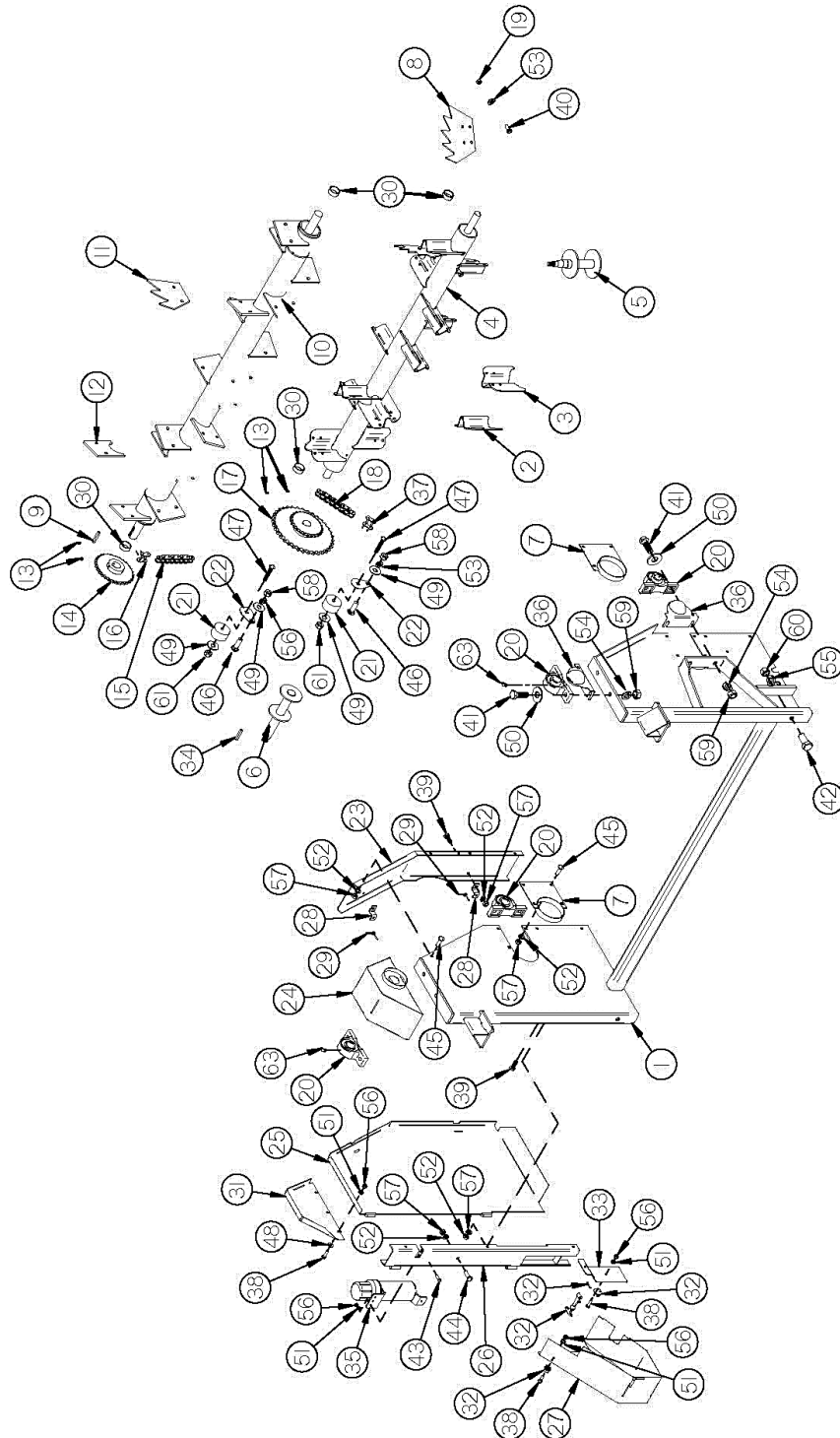

FIGURE 5

HORIZONTAL BEATER ASSEMBLY

<u>ITEM</u>	<u>QTY</u>	<u>PART#</u>	<u>DESCRIPTION</u>
1	1	42N35	BEATER PANEL
2	6	42N36	BLADE HOLDER RH
3	6	42N37	BLADE HOLDER LH
4	1	42N38	BEATER
5	1	56N69	BEATER STUB SHAFT
6	1	42N39	BEATER DRIVE SHAFT
7	2	42N40	BEATER SLOT FILLER
8	12	23N277	BEATER BLADE
9	1	S437	SQUARE KEY, 3/8 X 1-3/8
10	1	42N42	SECOND BEATER
11	16	45N27	BEATER BLADE 2ND
12	16	42N147	BEATER BLADE HOLDER
13	4	YSKP12025	SET SCREW, SOCKET, KNURLED CUP PT, 3/8 X 3/8
14	1	42N44	SECOND BEATER SPROCKET (30T)
15	1	42N45	SECOND BEATER CHAIN
16	1	D39	CONNECTOR LINK (#60)
17	1	42N46	BEATER SPROCKET (80-20-60-25)
*	1	42N47	BEATER SPROCKET (80-36-60-25)
*	1	74563	ROLLER CHAIN (#80), (88P)
18	1	16SV34	FINAL DRIVE CHAIN RH
19	80	YNTL16005	NUT HEX, TOP LOCK, 1/2
20	4	16SV72	PILLOW BLOCK BEARING W/ ZERK
21	2	42N50	POLY CHAIN TIGHTENER
22	2	42N51	TIGHTENER STOP
23	1	42N52	MAIN PANEL RIGHT END
24	1	42N53	SECOND BEATER ANTI-WRAP
25	1	42N54	REAR SHIELD
26	1	42N55	SHIELD FILLER
27	1	42N56	CROSS SHAFT SHIELD

NOTE: * MEANS NOT SHOWN

FIGURE 5
HORIZONTAL BEATER ASSEMBLY

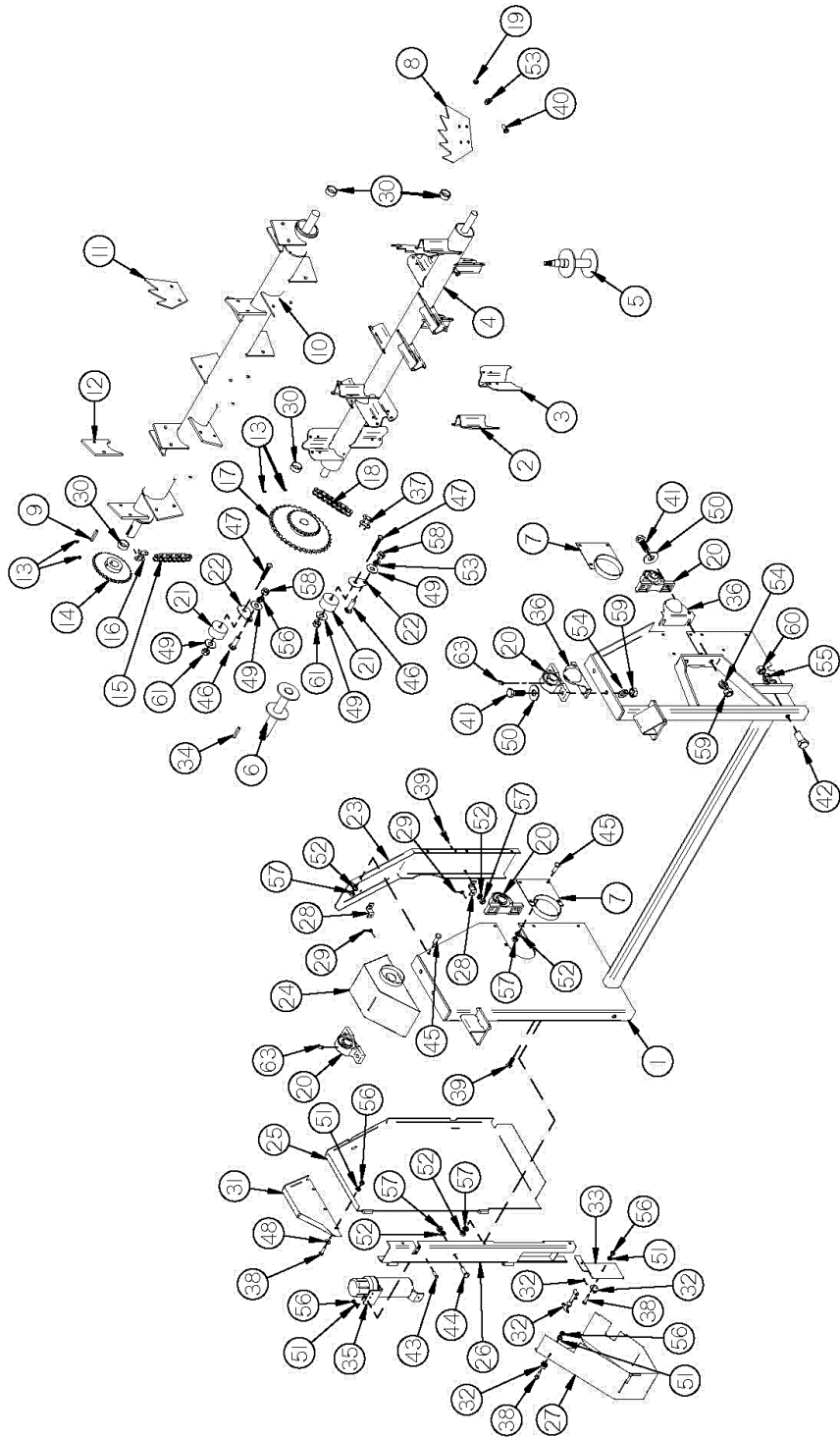

FIGURE 5

HORIZONTAL BEATER ASSEMBLY

<u>ITEM</u>	<u>QTY</u>	<u>PART#</u>	<u>DESCRIPTION</u>
28	2	F69	SHIELD BRACKET
29	2	YPLY08011	LYNCH PIN, 1/4 X 1-9/16
30	4	42N103	BEATER SPACER
31	1	42N104	SECOND BEATER SHIELD
32	1	X233	COMPLETE LATCH
33	1	42N105	BACK STAKE FILLER
34	1	42N141	KEY W/ ROUND ENDS, 3/8 X 2-1/4
35	1	S522	MANUAL HOLDER
36	2	42N142	STUB SHAFT SHIELD
37	1	F157	CONNECTOR LINK (#80)
38	5	YBHH08010	BOLT HEX, 1/4 X 1 G5
39	5	YBHH12010	BOLT HEX, 3/8 X 1 G5
40	80	YBHH16045	BOLT HEX, 1/2 X 1-1/4 G5
41	8	YBHH18015	BOLT HEX, 9/16 X 2 G5
42	2	YBHH24010	BOLT HEX, 3/4 X 1-1/2 G5
43	3	YSTM08004	SLOTTED TRUSS HEAD, MACHINE SCREW, 1/4 X 3/4
44	1	YBCR12065	BOLT CARRIAGE, 3/8 X 3/4 G5
45	11	YBCR12010	BOLT CARRIAGE, 3/8 X 1 G5
46	2	YBCR16015	BOLT CARRIAGE, 1/2 X 1-1/4 G5
47	2	YBCR16035	BOLT CARRIAGE, 1/2 X 2-3/4 G5
48	3	YWFL08005	WASHER FLAT, 1/4 USS
49	4	YWFL16005	WASHER FLAT, 1/2 USS
50	8	YWFL18005	WASHER FLAT, 9/16 USS
51	8	YWLO08005	WASHER LOCK, 1/4
52	17	YWLO12005	WASHER LOCK, 3/8
53	82	YWLO16005	WASHER LOCK, 1/2
54	8	YWLO18005	WASHER LOCK 9/16
55	2	YWLO24005	WASHER LOCK, 3/4
56	8	YNHX08005	NUT HEX, 1/4
57	17	YNHX12005	NUT HEX, 3/8
58	2	YNHX16005	NUT HEX, 1/2
59	8	YNHX18005	NUT HEX, 9/16
60	2	YNHX24005	NUT HEX, 3/4
61	2	YNRL16005	NUT HEX, REVERSIBLE - SIDE LOCK, 1/2

NOTE: * MEANS NOT SHOWN

FIGURE 6

PUSHER

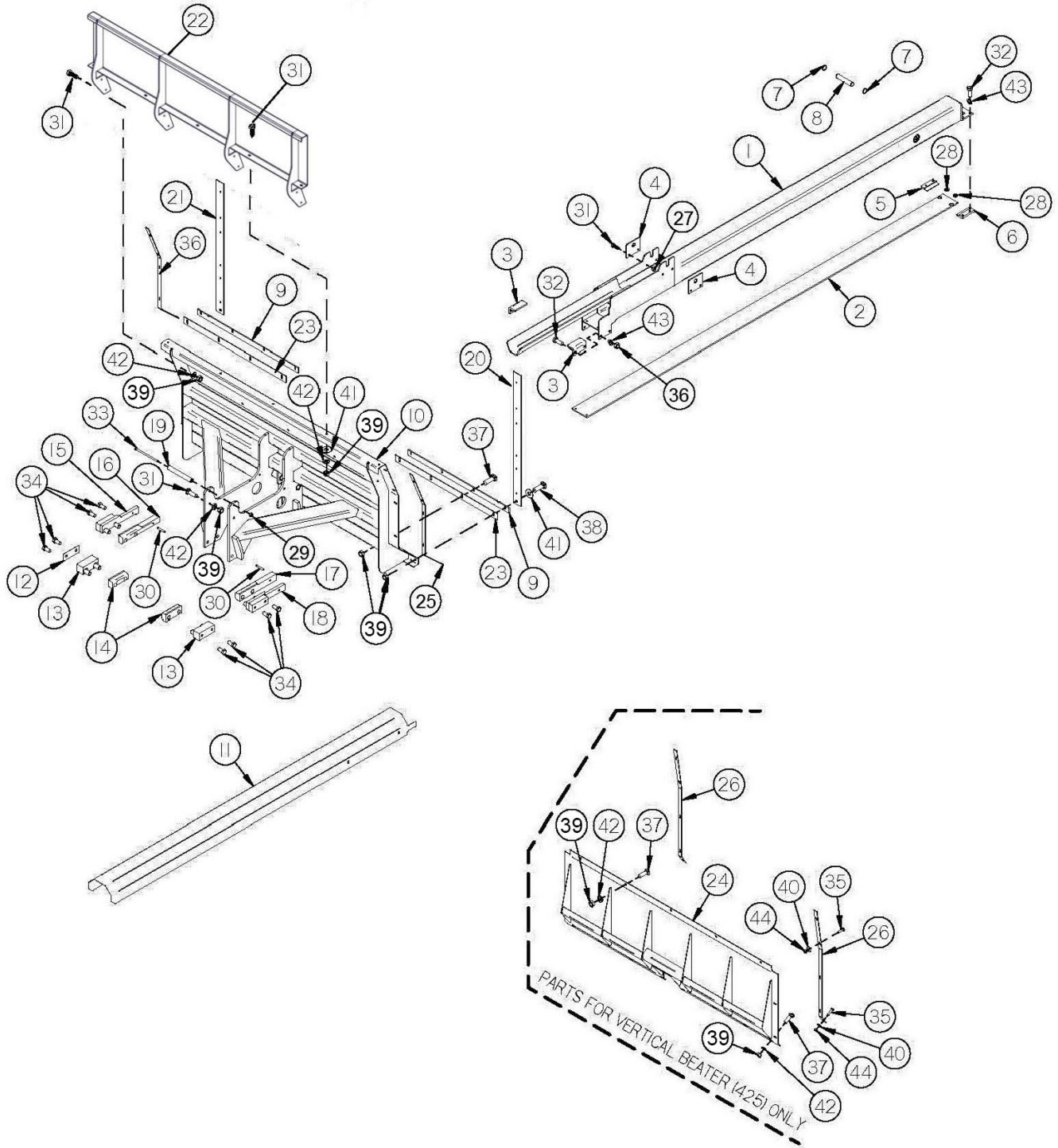

FIGURE 6

PUSHER

<u>ITEM</u>	<u>QTY</u>	<u>PART #</u>	<u>DESCRIPTION</u>
1	1	42N74	MOVEABLE FLOOR TUBE
2	1	42N149	PUSHER TUBING SLIDE
3	2	42N76	PUSHER TUBE FRONT GUIDE
4	2	42N77	CYLINDER RETAINER
5	1	42N78	END CAP CLAMP RH
6	1	42N79	END CAP CLAMP LH
7	2	3G21	SNAP RING, 1
8	1	42N80	REAR CYLINDER PIN
9	2	42N81	PUSHER WIPER
10	1	42N83	PUSHER
11	1	42N84	CYLINDER SHIELD
12	A/R	42N114	PUSHER SHIM
13	2	42N85	POLY BLOCK SPACER
14	2	42N86	PUSHER POLY SLIDE
15	1	42N87	POLY BLOCK SPACER RH
16	1	42N88	PUSHER POLY SLIDE RH
17	1	42N89	PUSHER POLY SLIDE LH
18	1	42N90	POLY BLOCK SPACER LH
19	1	42N91	PUSHER SPACER

NOTE: A/R MEANS AS REQUIRED

FIGURE 6

PUSHER

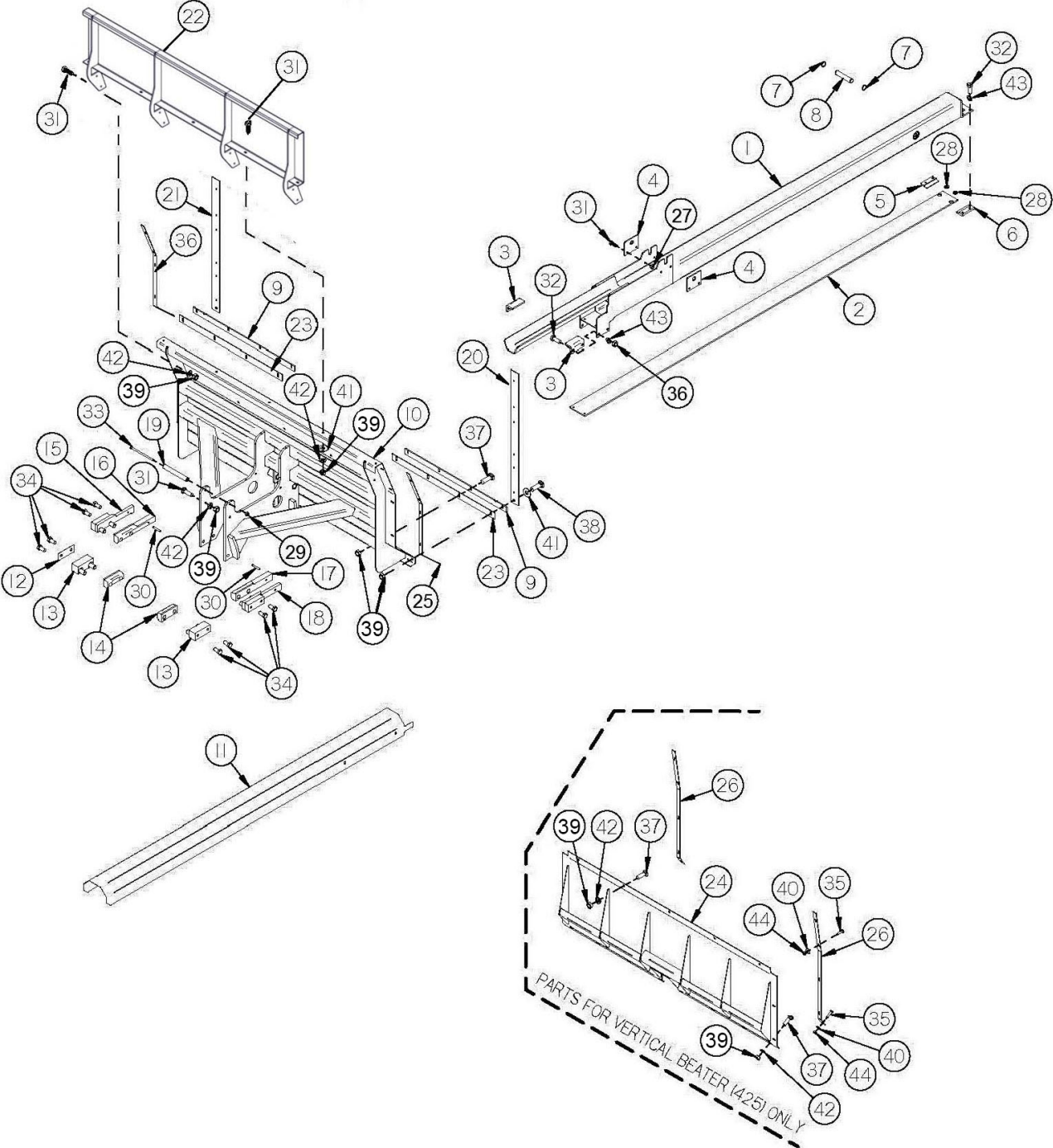

FIGURE 6

PUSHER

<u>ITEM</u>	<u>QTY</u>	<u>PART#</u>	<u>DESCRIPTION</u>
20	1	42N92	PUSHER RUBBER LH
21	1	42N93	PUSHER RUBBER RH
22	1	79355	PUSHER EXTENSION
23	2	42N139	PUSHER BOTTOM RUBBER
24	1	HGV115	FLAT PUSHER FACE
25	2	42N82	PUSHER RUBBER STRAP
26	2	HGV116	FLAT PUSHER SEAL STRAP
27	4	YNRL12005	NUT HEX , REVERSIBLE-SIDE LOCK, 3/8
28	2	42N150	POLY SPACER
*	1	42N151	SCRAPER
29	1	YNRL12005	NUT HEX , REVERSIBLE-SIDE LOCK, 3/8
30	2	YPEX12020	EXPANSION PIN, 3/8 X 2
31	17	YBHH12010	BOLT HEX, 3/8 X 1 G5
32	8	YBHH16045	BOLT HEX, 1/2 X 1-1/4 G5
33	1	YBHH16185	BOLT HEX, 1/2 X 9 G5
34	8	YBHH20015	BOLT HEX, 5/8 X 1-1/4 G5
35	6	YBCR08005	BOLT CARRIAGE, 1/4 X 1 G5
36	4	YNHX16005	NUT HEX, 1/2
37	19	YBCR12010	BOLT CARRIAGE, 3/8 X 1 G5
38	2	YBCR12015	BOLT CARRIAGE, 3/8 X 1-1/2 G5
39	34	YNHX12005	NUT HEX, 3/8
40	6	YWFL08005	WASHER FLAT, 1/4 USS
41	7	YWFL12005	WASHER FLAT, 3/8 USS
42	26	YWLO12005	WASHER LOCK, 3/8
43	8	YWLO16005	WASHER LOCK, 1/2
44	6	YNHX08005	NUT HEX, 1/4

NOTE: * MEANS NOT SHOWN

FIGURE 7
PUSHER & ENDGATE HYD COMPONENTS

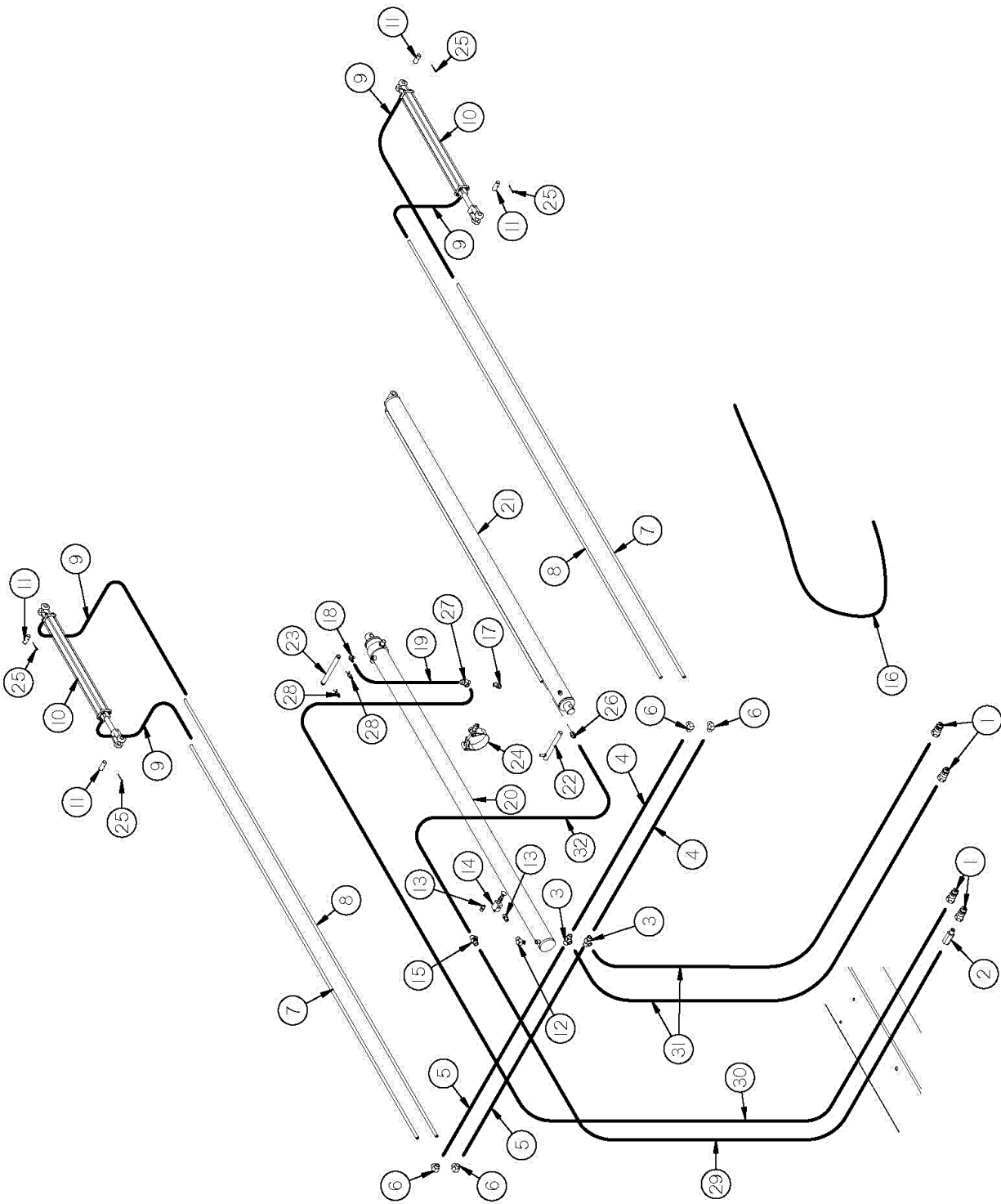

FIGURE 7
PUSHER & ENDGATE HYD. COMPONENTS

<u>ITEM</u>	<u>QTY</u>	<u>PART #</u>	<u>DESCRIPTION</u>
1	4	DWM205	MALE QUICK COUPLER
2	1	57735	CHECK VALVE
3	2	BFR74	TEE
4	2	46N40	HYD HOSE, 3/8 X 46
5	2	BFR287	HYD HOSE, 3/8 X 36
6	4	HE59	FEMALE ELBOW, 3/8
7	2	42N59	ENDGATE HYD LINE SHORT
8	2	42N60	ENDGATE HYD LINE LONG
9	4	12V19	HYD HOSE, 3/8 X 24
10	2	56002	HYD CYLINDER, (2 X 20)
11	4	56N141	CYLINDER PIN
12	1	23N234	FITTING, 3/8 NPT X 1/4 NPT, 90 DEGREE
13	1	16SV351	NIPPLE, 3/8
14	1	16SV339	SEQUENCE VALVE
15	1	WM146	TEE MALE, 3/8
16	1	42N64	HOSE SHIELD, 1-1/2 X 73
17	1	42N67	UNION ADAPTER, 3/8, 45 DEG.
18	1	DWM110	ADAPTER, 3/8 MALE TO 3/8 FEMALE, 90 DEG. SWIVEL
19	1	42N68	HYD HOSE, 3/8 X 20-1/2

FIGURE 7
PUSHER & ENDGATE HYD. COMPONENTS

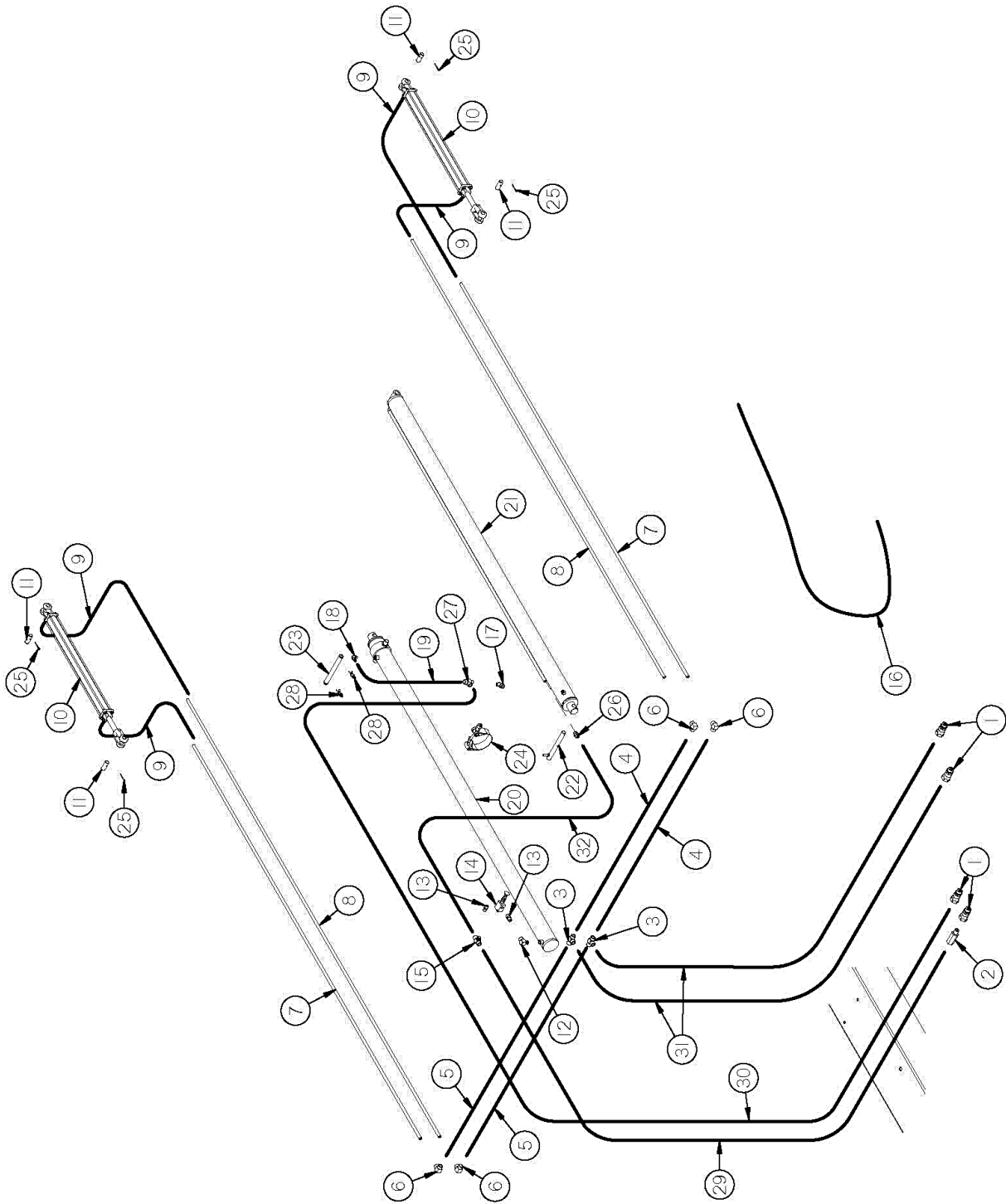

FIGURE 7

PUSHER & ENDGATE HYD. COMPONENTS

<u>ITEM</u>	<u>QTY</u>	<u>PART #</u>	<u>DESCRIPTION</u>
20	1	42N70	HYD CYLINDER, 3-1/2 X 90
21	1	42N69	HYD CYLINDER, 3-1/2 X 90
22	1	42N71	CYLINDER PIN
23	1	42N72	PUSHER CYLINDER PIN
24	1	12V70	HOSE CLAMP
25	4	YPCT07005	COTTER PIN, 7/32 X 2
26	1	DWM233	MALE ADAPTER, 3/8
27	1	23N116	SERVICE TEE
28	2	T144	CLIP PIN
29	1	HGV168	HYD HOSE, 3/8 X 186
30	1	HGV169	HYD HOSE, 3/8 X 260
31	2	HGV167	HYD HOSE, 3/8 X 157
32	1	42N66	HYD HOSE, 3/8 X 76

FIGURE 8

ENDGATE CYLINDER

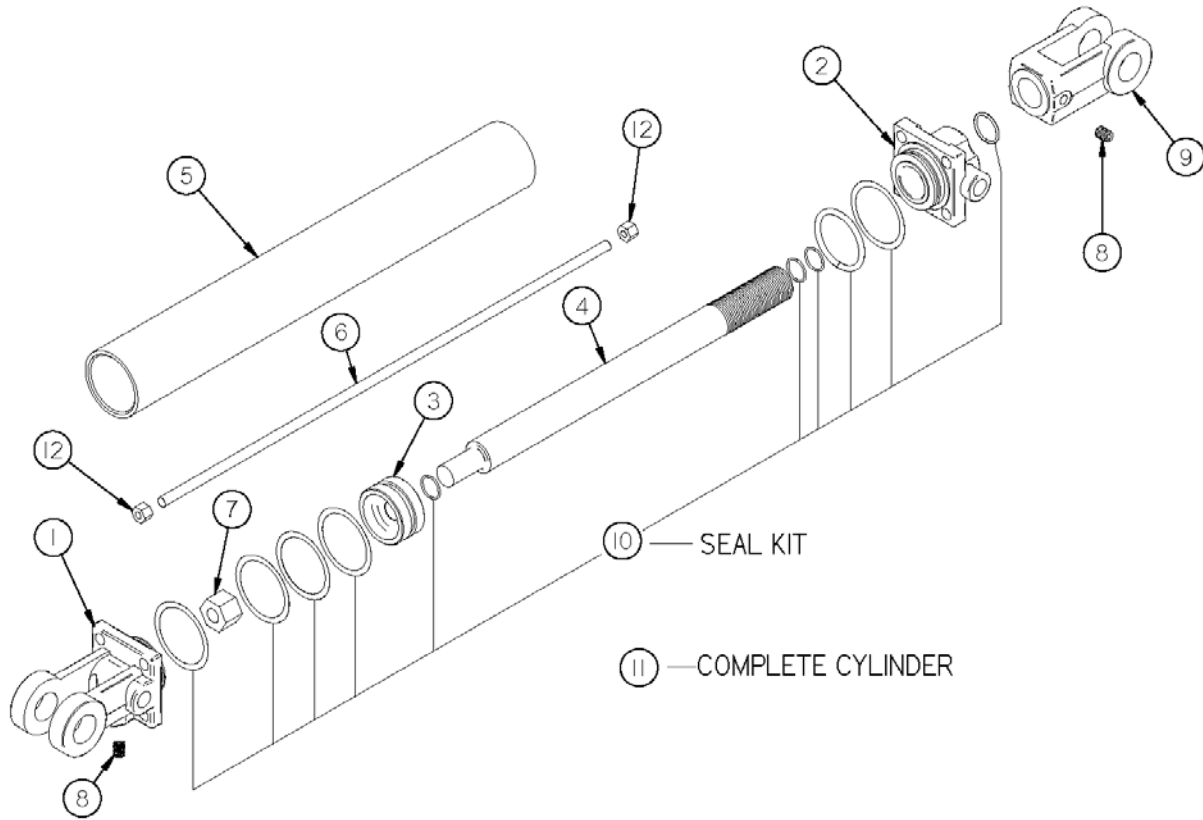

FIGURE 8
ENDGATE CYLINDER

<u>ITEM</u>	<u>QTY</u>	<u>PART#</u>	<u>DESCRIPTION</u>
1	1	23N142A	CLEVIS CAP
2	1	56174	ROD CAP
3	1	56180	PISTON
4	1	45N42	ROD
5	1	45N43	CYLINDER TUBE
6	4	45N44	TIE ROD
7	1	23N148	PISTON NUT
8	2	23N149	PLUG
9	1	23N150A	ROD CLEVIS
10	1	56187	SEAL KIT
11	1	56002	HYDRAULIC CYLINDER
12	8	YNHX12005	NUT HEX, 3/8

FIGURE 9 HYDRAULIC PUSHER CYLINDER

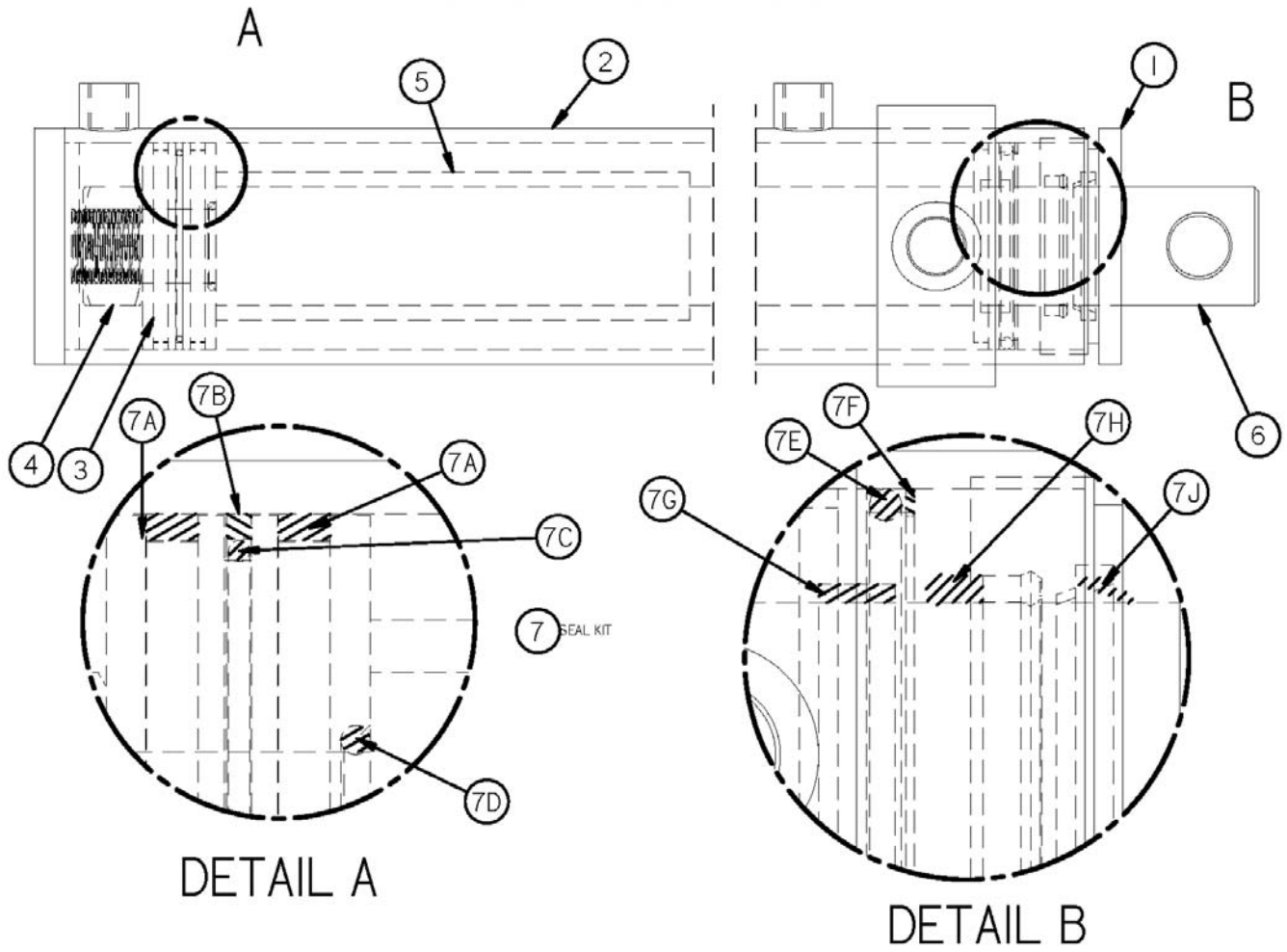

FIGURE 9

HYDRAULIC PUSHER CYLINDER

<u>ITEM</u>	<u>QTY</u>	<u>PART #</u>	<u>DESCRIPTION</u>
1	1	42N106	INTERNAL HEAD
2	1	42N107	BARREL ASSM (TOP CYL)
*	1	42N108	BARREL ASSM (BOTTOM CYL)
3	1	42N109	PISTON
4	1	42N110	LOCKNUT
5	1	42N111	SPACER
6	1	42N112	ROD
7	1	42N113	SEAL KIT (INC ITEMS 7A THRU 7J)
7A	2	"	WEAR RING
7B	1	"	P
7C	1	"	O-RING
7D	1	"	O-RING
7E	1	"	O-RING
7F	1	"	BACK-UP RING
7G	1	"	WEAR RING
7H	1	"	LOADED U-CUP
7J	1	"	ROD WIPER
*	1	42N69	COMP. CYL. - TOP
*	1	42N70	COMP. CYL. - BOTTOM

NOTE: * MEANS NOT SHOWN

FIGURE 10
BEATER GEARBOX

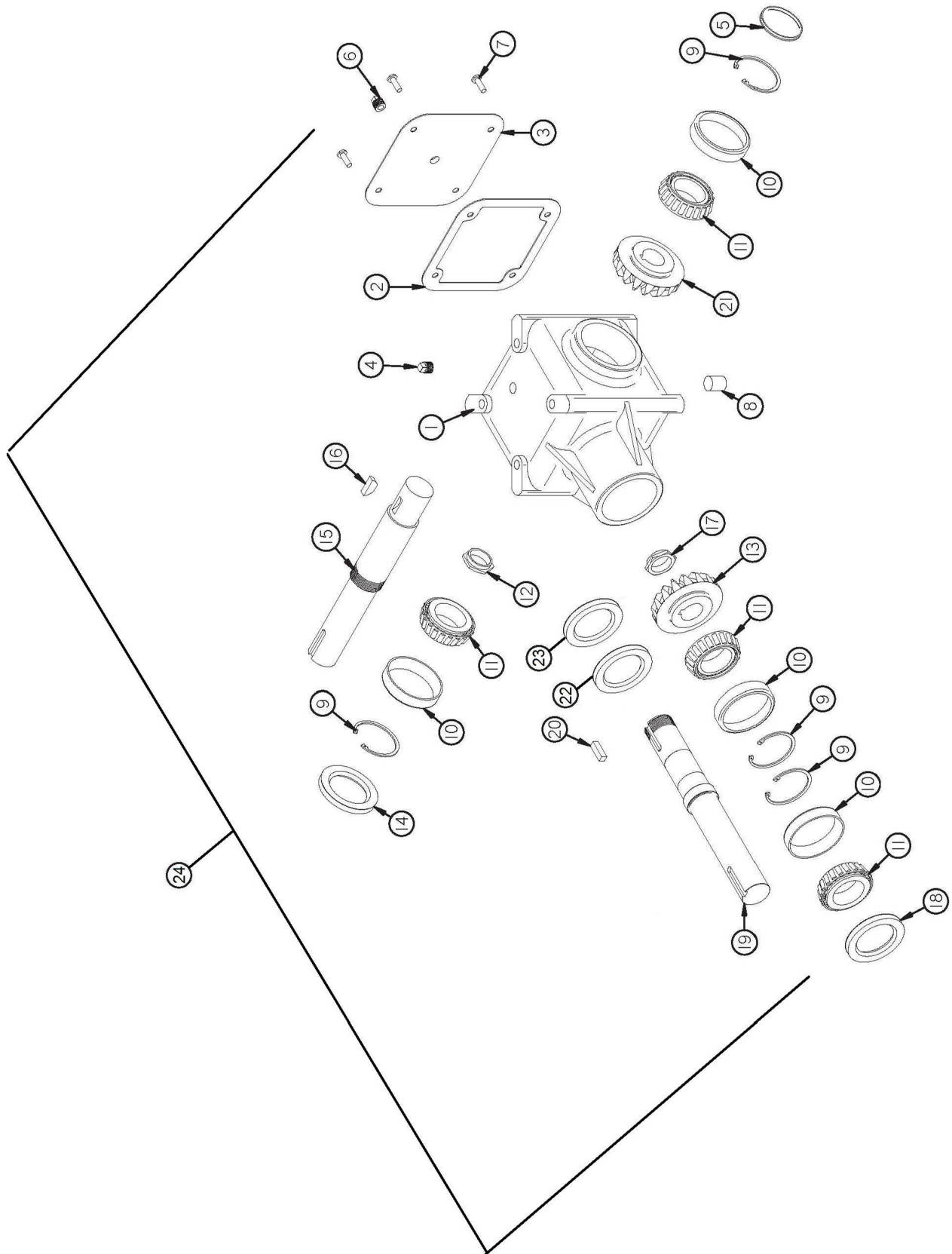

FIGURE 10
BEATER GEARBOX

<u>ITEM</u>	<u>QTY</u>	<u>PART #</u>	<u>DESCRIPTION</u>
1	1	G125	SHIM
2	1	G138	GASKET
3	1	G126	COVER
4	1	G144	VENT PLUG
5	1	G140	CAP
6	1	G65	PLUG PIPE, 3/8 NPT
7	4	G131	CAPSCREW
8	1	G145	PLUG
9	4	G130	SNAP RING
10	4	G128	BEARING CUP
11	4	G129	BEARING CONE
12	1	G132	STAKE NUT
13	1	G142	BEVEL GEAR (22T)
14	1	G136	SEAL-OUTPUT
15	1	42N57	OUTPUT SHAFT
16	1	5B9	WOODRUFF KEY
17	1	G133	STAKE NUT
18	1	G137	INPUT SEAL
19	1	42N58	INPUT SHAFT
20	1	50N140	SQUARE KEY, 3/8 X 1
21	1	G127	BEVEL GEAR
22	1	G141	SHIM
23	1	58420	SHIM
24	1	42N26	COMPLETE GEARBOX

FIGURE 11
VERTICAL BEATERS FRAME ASSEMBLY

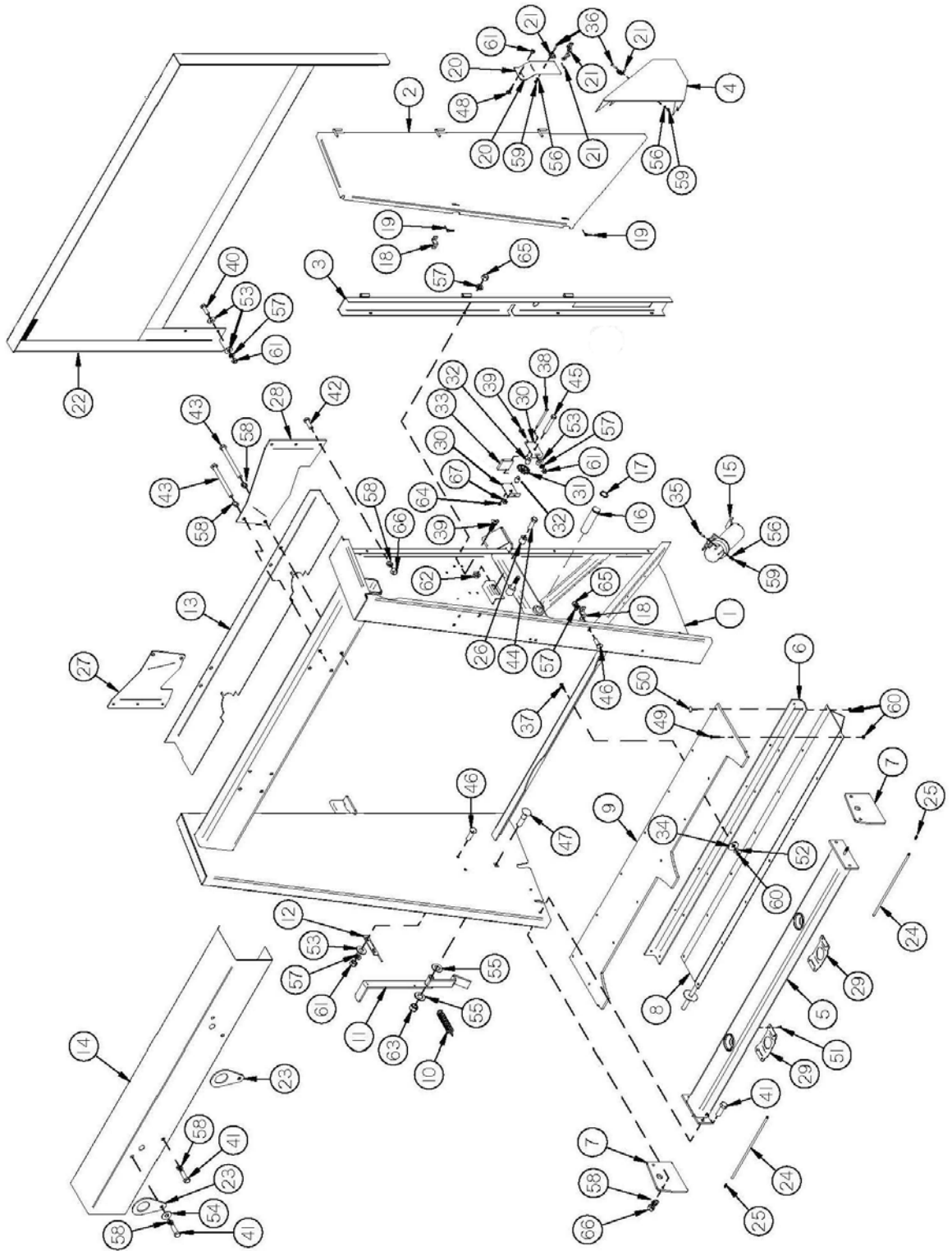

FIGURE 11

VERTICAL BEATERS FRAME ASSEMBLY

<u>ITEM</u>	<u>QTY</u>	<u>PART #</u>	<u>DESCRIPTION</u>
1	1	HGV54	FRAME
2	1	77526	REAR SHIELD
3	1	77527	SHIELD FILLER
4	1	HGV7	CROSS SHAFT SHIELD
5	1	HGV8	BEATER BOTTOM MOUNT
6	1	HGV9	PAN HINGE
7	2	HGV10	LEG
8	1	HGV11	PAN BOTTOM
9	1	HGV12	PAN
10	1	K103	SPRING
11	1	HGV13	PAN HANDLE
12	1	HGV14	PAN HANDLE STOP
13	1	HGV56	GEARBOX BOTTOM SHIELD SUPERIOR
14	1	HGV57	GEARBOX TOP SHIELD SUPERIOR
15	1	S522	MANUAL HOLDER
16	1	HGV18	SPROCKET IDLER SHAFT
17	1	12V62	SNAP RING
18	2	F69	SHIELD BRACKET
19	2	GM572	CLIP PIN W/LANYARD
20	1	42N105	BACK STAKE FILLER
21	1	X233	COMPLETE LATCH
22	1	79411	STONE GUARD
23	2	HGV50	LIFTING EYE
24	2	HGV51	GREASE LINE
25	2	56694	GREASE FITTING
26	1	16SV44	TIGHTENER SPACER
27	1	HGV134	MAIN PANEL BRACE LH
28	1	HGV133	MAIN PANEL BRACE RH
29	2	26VB56	HUB CAP RETAINER
30	2	HGV100	IDLER BRACKET
31	1	16SV328	SPROCKET W/BEARING (80-C-12)
32	2	HGV111	SPROCKET SPACER
33	1	HGV109	CHAIN POLY BLOCK
*	1	HGV117	TIGHTENER ASSEMBLY
34	7	YWCU12005	WASHER CUSTOM, FLAT, .435 ID. X 1-7/8 OD. X .125 THICK
35	3	YBHH08100	BOLT HEX, 1/4 X 3/4 G5

NOTE: * MEANS NOT SHOWN

FIGURE 11

VERTICAL BEATERS FRAME ASSEMBLY

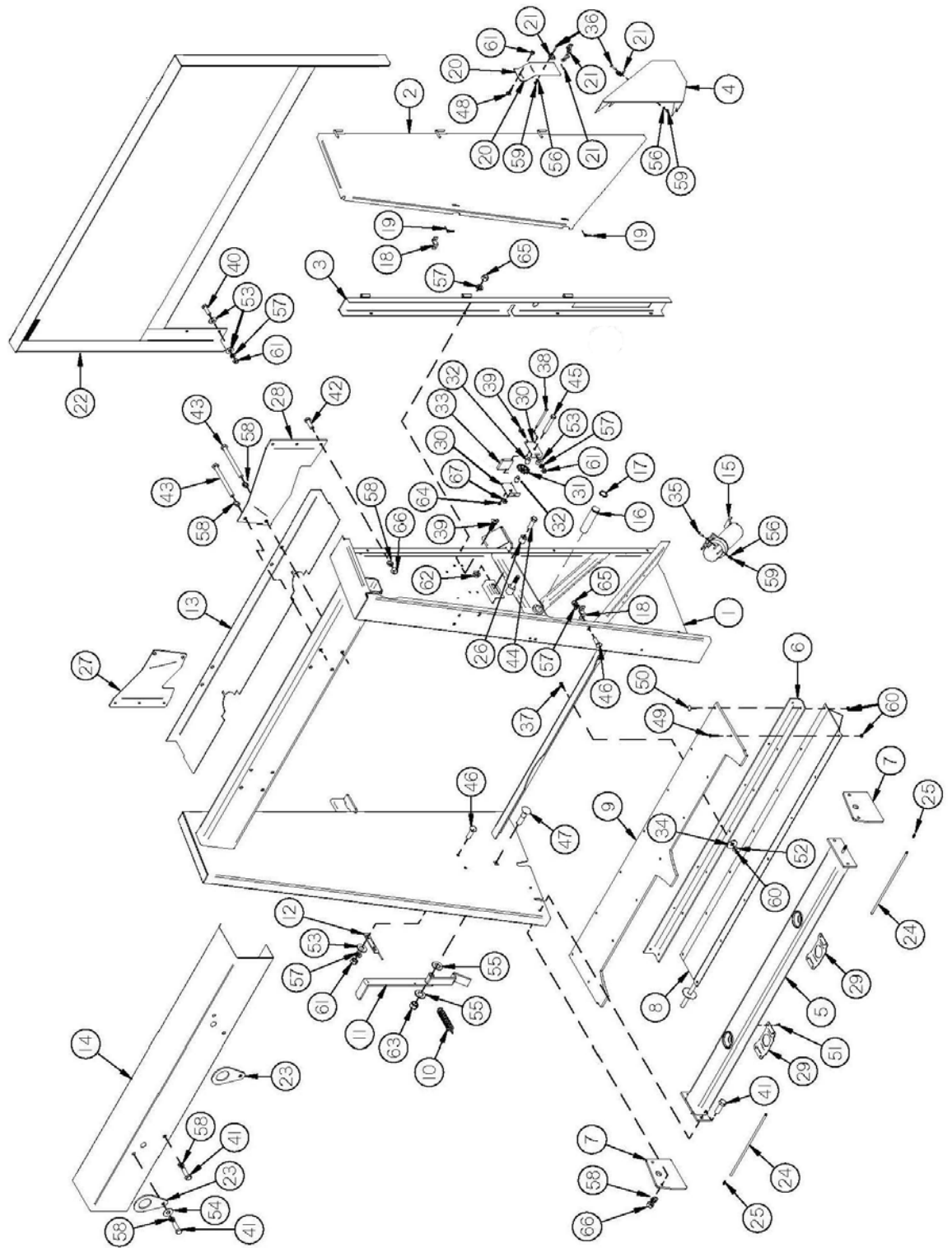

FIGURE 11

VERTICAL BEATERS FRAME ASSEMBLY

<u>ITEM</u>	<u>QTY</u>	<u>PART #</u>	<u>DESCRIPTION</u>
36	2	YBHH08010	BOLT HEX, 1/4 X 1 G5
37	7	YBHH10010	BOLT HEX, 5/16 X 1 G5
38	2	YBHH10125	BOLT HEX, 5/16 X 4-1/2 G5
39	6	YBHH12010	BOLT HEX, 3/8 X 1 G5
40	4	YBHH12035	BOLT HEX, 3/8 X 1-1/4 G5
41	8	YBHH16030	BOLT HEX, 1/2 X 1-1/2 G5
42	6	YBHH16047	BOLT HEX, 1/2 X 1-1/4 G5 (3/4 MAX THREADS)
43	8	YBHH16160	BOLT HEX, 1/2 X 5-1/2 G5
44	1	YBHH24035	BOLT HEX, 3/4 X 2-1/4 G5
45	1	YBHH24080	BOLT HEX, 3/4 X 5 G5
46	4	YBCR12010	BOLT CARRIAGE, 3/8 X 1 G5
47	1	HGV108	LATCH PIVOT BOLT
48	1	YBPL12010	FLAT HEAD, PLOW BOLT, 3/8 X 1-1/4 G5
49	7	YSFS10005	FLAT HEAD, SOCKET CAP SCREW, 5/16 X 1
50	7	YBSB10005	BOLT STEP, 5/16 X 1-1/2
51	8	YSDR08005	SELF DRILLING SCREW, 1/4 X 1
52	7	YWFL10005	WASHER FLAT, 5/16 USS
53	12	YWFL12005	WASHER FLAT, 3/8 USS
54	2	YWFL16005	WASHER FLAT, 1/2 USS
55	2	16SV49	SHIM, .074
56	5	YWLO08005	WASHER LOCK, 1/4
57	14	YWLO12005	WASHER LOCK, 3/8
58	22	YWLO16005	WASHER LOCK, 1/2
59	5	YNHX08005	NUT HEX, 1/4
60	21	YNHX10005	NUT HEX, 5/16
61	9	YNHX12005	NUT HEX, 3/8
62	1	YNFG24005	NUT HEX, FLANGED - LOCK, 3/4
63	1	YNRL24005	NUT HEX, REVERSIBLE - SIDE - LOCK, 3/4
64	2	YNTL10005	NUT HEX, TOP LOCK, 5/16
65	7	YNTL12005	NUT HEX, TOP LOCK, 3/8
66	10	YNTL16005	NUT HEX, TOP LOCK, 1/2
67	1	YNTL24005	NUT HEX, TOP LOCK, 3/4

FIGURE 12
VERTICAL BEATERS DRIVE TRAIN



FIGURE 12

VERTICAL BEATERS DRIVE TRAIN

<u>ITEM</u>	<u>QTY</u>	<u>PART #</u>	<u>DESCRIPTION</u>
1	1	HGV118	BEATER LH
2	1	HGV120	BEATER RH
3	21	HGV122	BEATER BLADE LH
4	21	HGV123	BEATER BLADE RH
5	2	HGV27	SEAL
6	2	B5	BEARING CONE
7	2	B5A	BEARING CUP
8	2	3G18	BEARING CUP
9	2	3G7	BEARING CONE
10	2	17G144	HUB CAP
11	2	56N174	SQUARE KEY W/ ROUND ENDS, 3/8 X 2 (HARD)
12	1	HGV58	COMPLETE GEARBOX LH
13	2	26VB37	BEATER HEX PLUG
14	6	42N25	SPROCKET, (50-B-20)
15	3	HGV124	CONNECTOR CHAIN, (#50) (20P)
*	3	D118	CONNECTOR LINK (#50)
16	1	HGV59	GEARBOX CROSS SHAFT
17	1	HGV60	COMPLETE GEARBOX RH
18	1	HGV61	GEARBOX DRIVE SHAFT
19	1	HGV41	BEARING
20	1	HGV25	SPROCKET, (80-B-20)
21	1	HGV126	ROLLER CHAIN, (#80H) (98P)
*	1	F157	CONNECTOR LINK, (#80H)
*	A/R	HGV163	HALF CHAIN LINK, (80H)
22	2	12V52	BEARING
23	2	12N77	IDLER SPROCKET W/BEARING, (80-A-12)
24	1	HGV36	BEATER TIGHTENER
25	2	42N164	BEARING
*	2	16SV375	SHIM .130
26	1	HGV38	SPROCKET, (80-A-20 TO 80-A-20) 540 RPM
*	1	HGV37	SPROCKET, (80-A-36 & 80-A-20) 1000 RPM
*	1	74573	ROLLER CHAIN, (#80H), (117P)
27	1	HGV128	DRIVE CHAIN, (#80H), (109P) 540 RPM
*	1	HGV127	DRIVE CHAIN, (#80H), (117P) 1000 RPM

NOTE: * MEANS NOT SHOWN

A/R: AS REQUIRED

FIGURE 12

VERTICAL BEATERS DRIVE TRAIN



FIGURE 12

VERTICAL BEATERS DRIVE TRAIN

<u>ITEM</u>	<u>QTY</u>	<u>PART #</u>	<u>DESCRIPTION</u>
*	1	F157	CONNECTOR LINK, (#80H)
28	1	10R14	SPRING
29	1	HGV30	SPACER
30	2	HGV43	PRIMARY TIGHTENER SPACER
31	1	HGV42	TIGHTENER
32	2	56N160	SPRING HOLDER
33	1	ST36	SPRING
34	8	26VB57	FAN BLADE
35	2	HGV129	BEATER RUBBER SEAL
36	2	HGV130	BEATER SEAL CAP
37	2	HGV102	BEATER STUB SHAFT
38	7	PB136	SQUARE KEY W/ROUND ENDS, 3/8 X 2
39	2	YPCT05020	COTTER PIN, 5/32 X 1-1/2
40	16	YSKP12025	SET SCREW, SOCKET, KNURLED CUP PT, 3/8 X 3/8
41	12	YBHH08100	BOLT HEX, 1/4 X 3/4 G5
42	3	YBHH18010	BOLT HEX, 9/16 X 1-3/4 G5
43	1	YBHH18115	BOLT HEX, 9/16 X 2-1/2 G5
44	84	YBHH20020	BOLT HEX, 5/8 X 1-3/4 G5
45	2	YBHH24050	BOLT HEX, 3/4 X 3 G5
46	16	YBCR16010	BOLT CARRIAGE, 1/2 X 1-1/2 G5
47	2	YBTE12045	TURNED EYE BOLT, 3/8 X 5
48	2	YWFL12005	WASHER FLAT, 3/8 USS
49	1	YWFL24005	WASHER FLAT, 3/4 USS
50	2	YWFL24010	WASHER FLAT, 3/4 SAE
51	12	YWLO08005	WASHER LOCK, 1/4
52	2	YWLO12005	WASHER LOCK, 3/8
53	16	YWLO16005	WASHER LOCK, 1/2
54	5	YWLO18005	WASHER LOCK, 9/16
55	84	YWLO20005	WASHER LOCK, 5/8
56	2	YNHX12005	NUT HEX, 3/8
57	5	YNHX18005	NUT HEX, 9/16
58	2	YNRL24005	NUT HEX, REVERSIBLE - SIDE LOCK, 3/4
59	2	YNL12005	NUT HEX, TOP LOCK, 3/8
60	16	YNL16005	NUT HEX, TOP LOCK, 1/2
61	84	YNL20005	NUT HEX, TOP LOCK, 5/8
62	1	YNL24005	NUT HEX, TOP LOCK, 3/4
63	2	YNSL24010	NUT HEX, SLOTTED, 3/4
64	1	60533	TIGHTER SPACER

NOTE: * MEANS NOT SHOWN

FIGURE 13

SUPERIOR GEARBOX LEFT

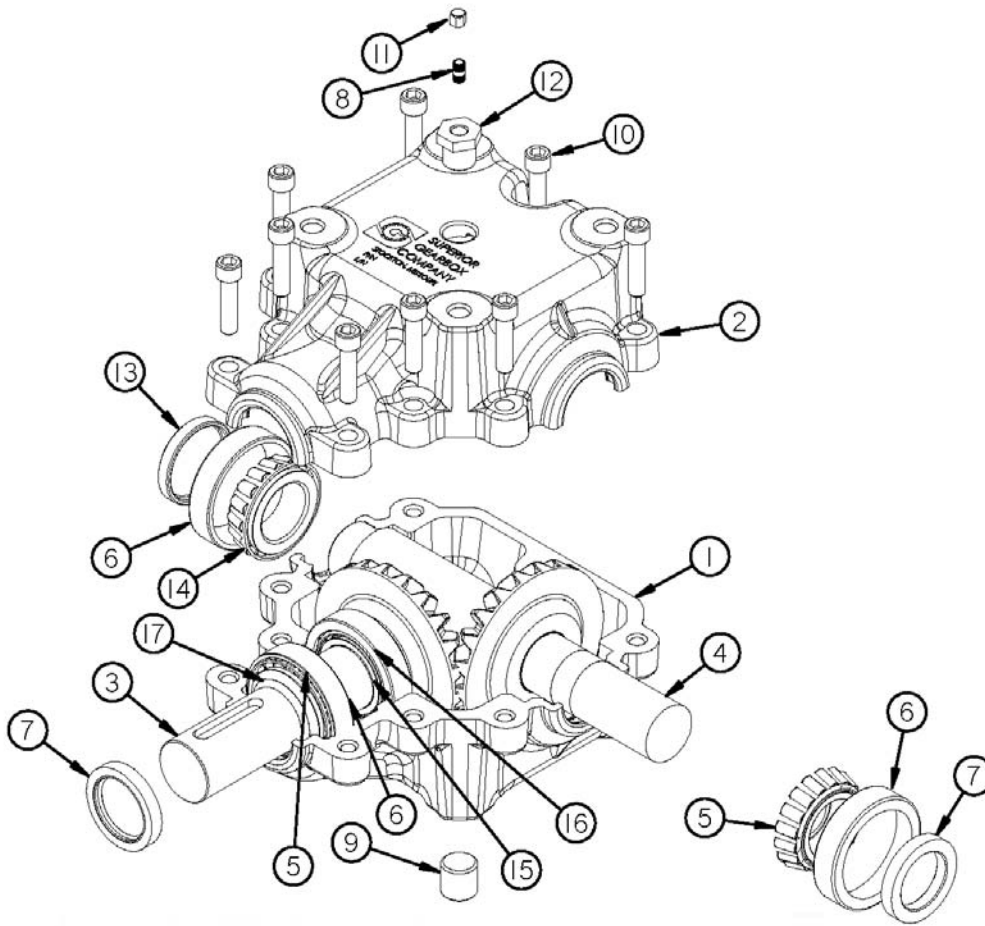

<u>ITEM</u>	<u>QTY</u>	<u>PART #</u>	<u>DESCRIPTION</u>
1	1	HGV88	BOTTOM HOUSING
2	1	HGV89	TOP HOUSING
3	1	HGV90	OUTPUT SHAFT
4	1	HGV105	INPUT SHAFT
5	2	HGV91	BEARING CONE
6	3	HGV92	BEARING CUP
7	2	HGV93	SEAL
8	1	23N288	NIPPLE, 3/8
9	1	HGV95	PLUG, 1/2 NPT
10	9	YSHS12012	SOCKET HEAD CAP SCREW, 3/8 X 2-1/4
11	1	17G58	VENT CAP
12	1	JB82	BUSHING, 1/2 TO 3/8
13	1	HGV99	CAP
14	1	HGV94	BEARING CONE
15	1	HGV97	BEARING CONE
16	1	HGV112	BEARING CUP
17	1	HGV98	RETAINING PING
*	1	HGV58	COMPLETE GEARBOX LH

NOTE: * MEANS NOT SHOWN

FIGURE 14

SUPERIOR GEARBOX RIGHT

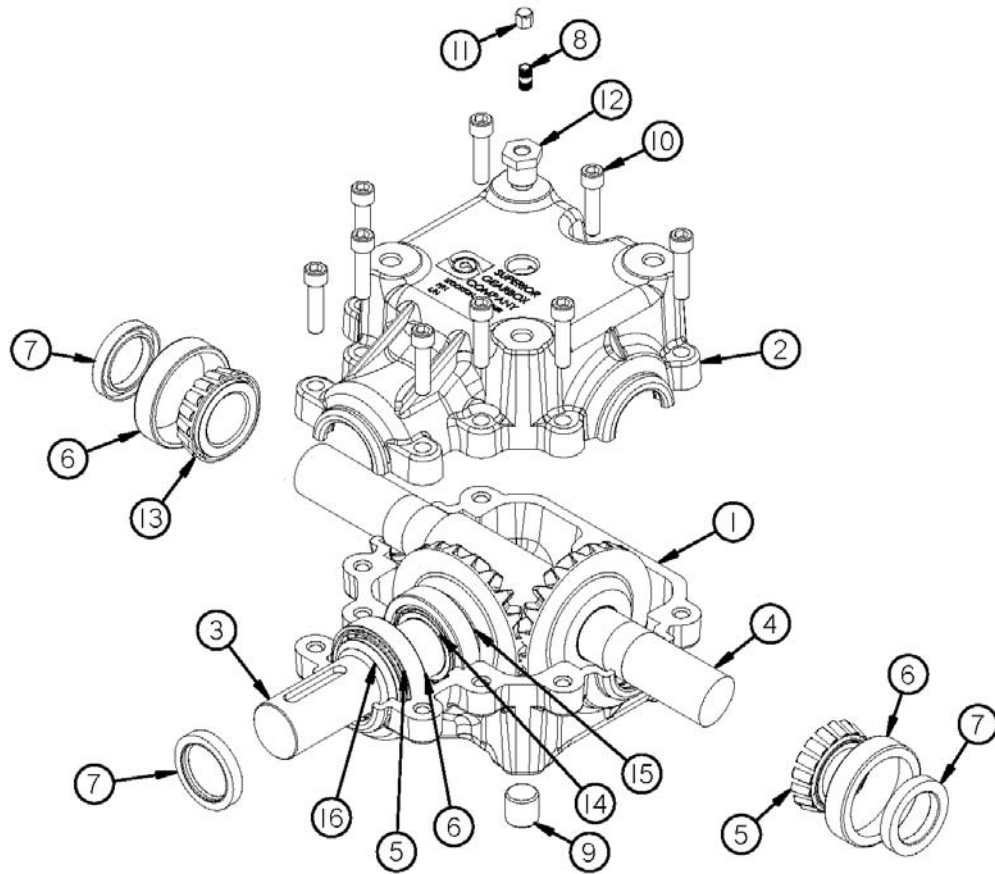

<u>ITEM</u>	<u>QTY</u>	<u>PART #</u>	<u>DESCRIPTION</u>
1	1	HGV88	BOTTOM HOUSING
2	1	HGV89	TOP HOUSING
3	1	HGV90	OUTPUT SHAFT
4	1	HGV101	INPUT SHAFT
5	2	HGV91	BEARING CONE
6	3	HGV92	BEARING CUP
7	3	HGV93	SEAL
8	1	23N288	NIPPLE, 3/8
9	1	HGV95	PLUG, 1/2 NPT
10	9	YSHS12012	SOCKET HEAD CAP SCREW, 3/8 X 2-1/4
11	1	17G58	VENT CAP
12	1	JB82	BUSHING, 1/2 TO 3/8
13	1	HGV94	BEARING CONE
14	1	HGV97	BEARING CONE
15	1	HGV112	BEARING CUP
16	1	HGV98	RETAINING RING
*	1	HGV60	COMPLETE GEARBOX RH

NOTE: * MEANS NOT SHOWN

FIGURE 15 CHAIN OILER

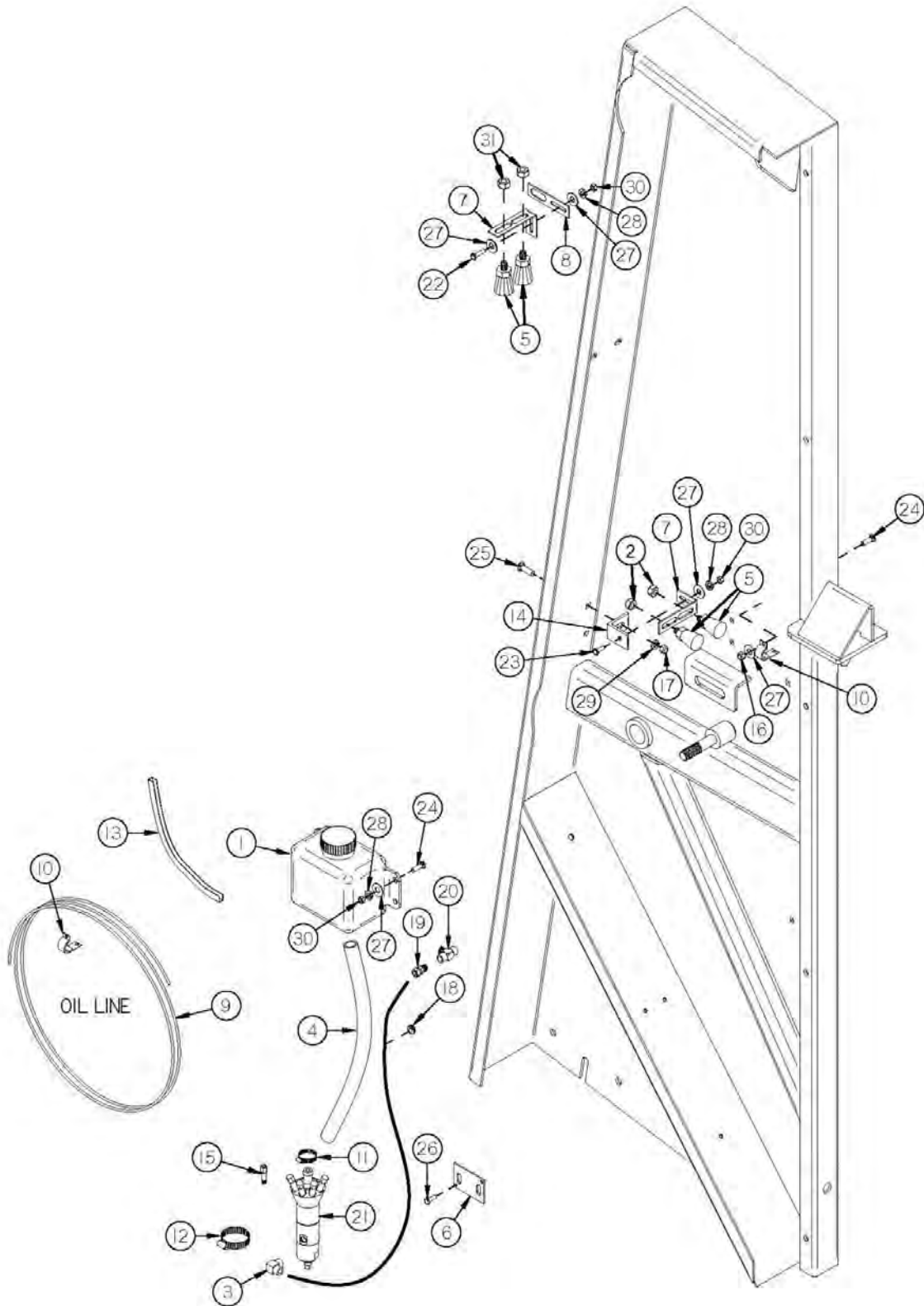

FIGURE 15

CHAIN OILER

<u>ITEM</u>	<u>QTY</u>	<u>PART #</u>	<u>DESCRIPTION</u>
1	1	HGV63	RESERVOIR
2	2	YNHX16005	NUT HEX, 1/2
*	1	GM501	HYD HOSE, 1/4 X 29-3/4
3	1	HGV65	O-RING/JIC ELBOW
4	4	HGV66	FILLER HOSE
5	4	HGV67	BRUSH
6	1	HGV135	OILER MOUNT
7	2	HGV69	BRUSH BRACKET
8	1	HGV70	BRACKET MOUNT
9	1	HGV71	OILER TUBE 5/32 OD
10	5	HGV72	SMALL TUBE HOLDER
11	2	HGV75	HOSE CLAMP, 1
12	1	HGV74	HOSE CLAMP, 2
13	1	HGV77	EDGING, (12)
14	1	HGV170	ANGLE
15	4	HGV84	COMPLETE MANIFOLD
16	3	YNTL08005	NUT HEX, TOP LOCK, 1/4
17	1	YNTL12005	NUT HEX, TOP LOCK, 3/8
*	1	8613	OILER KIT
18	1	8651	RUBBER GROMMET
19	1	BFR120	UNION ADAPTER, 3/8
20	1	WM146	MALE BRANCH TEE, 3/8
21	1	HGV82	PUMP (COMPLETE)
*	1	HGV83	REPAIR KIT
22	11	YBHH08010	BOLT HEX, 1/4 X 1 G5
23	1	YBHH08100	BOLT HEX, 1/4 X 3/4 G5
24	7	YBCR08040	BOLT CARRIAGE, 1/4 X 3/4 G5
25	1	YBCR12010	BOLT CARRIAGE, 3/8 X 1 G5
26	2	YSDR08015	HEX WASHER HEAD SLOT THRD ROLL SCREW, 1/4 X 1/2
27	11	YWFL08005	WASHER FLAT, 1/4 USS
28	6	YWLO08005	WASHER LOCK, 1/4
29	1	YWLO12005	WASHER LOCK, 3/8
30	6	YNHX08005	NUT HEX, 1/4

NOTE: * MEANS NOT SHOWN

FIGURE 16

LIGHTING

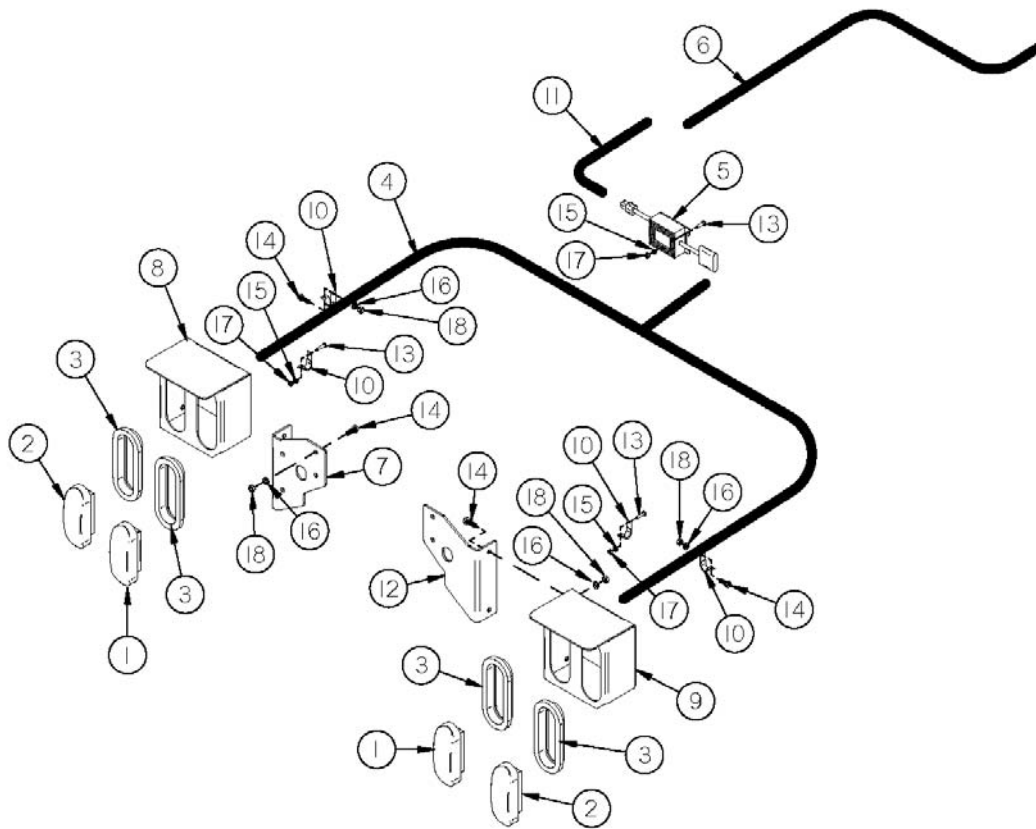

<u>ITEM</u>	<u>QTY</u>	<u>PART #</u>	<u>DESCRIPTION</u>
1	2	S310	RED TAILLIGHT
2	2	S309	AMBER TAILLIGHT
3	4	S308	RUBBER LIGHT MOUNT
4	1	56N155	HARNESS, TAILLIGHT
5	1	69908	CONTROL BLINKER MODULE
6	1	1140	WIRE HARNESS
7	1	HGV137	LIGHT BRACKET MOUNT LH
8	1	55N61	LIGHT BRACKET LH
9	1	55N62	LIGHT BRACKET RH
10	14	55N64	METAL CUSHIONED CABLE
11	1	BFR666	LIGHT HARNESS
12	1	HGV136	LIGHT BRACKET MOUNT RH
13	5	YBHH08010	BOLT HEX, 1/4 X 1 G5
14	10	YBHH12010	BOLT HEX, 3/8 X 1 G5
15	5	YWLO08005	WASHER LOCK, 1/4
16	10	YWLO12005	WASHER LOCK, 3/8
17	5	YNHX08005	NUT HEX, 1/4
18	10	YNHX12005	NUT HEX, 3/8

FIGURE 17

OPTIONAL REAR PAN

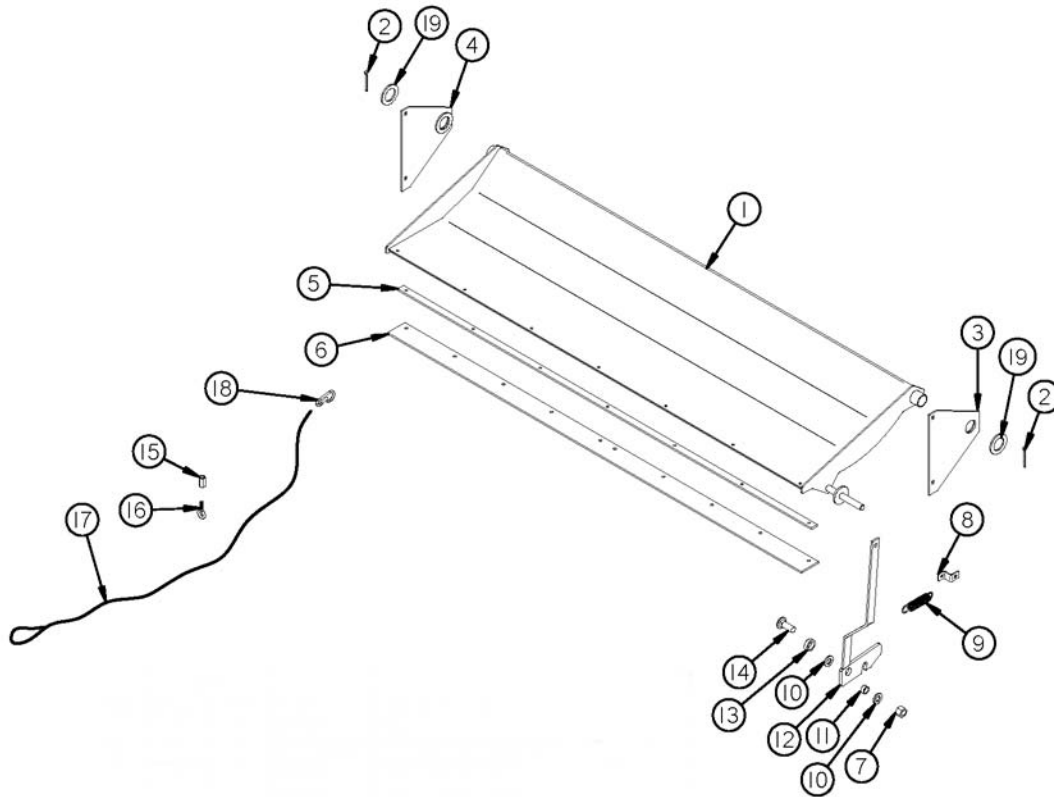

<u>ITEM</u>	<u>QTY</u>	<u>PART #</u>	<u>DESCRIPTION</u>
1	1	42N127	PAN
2	2	YPCT06020	COTTER PIN, 3/16 X 2
3	1	42N128	PAN PLATE LH
4	1	42N129	PAN PLATE RH
5	1	42N130	PAN STRAP
6	1	42N131	RUBBER
7	1	YNTL24005	NUT HEX, TOP LOCK, 3/4
8	1	F69	SHIELD BRACKET
9	1	ST36	SPRING
10	2	T73	WASHER
11	1	42N132	LATCH BUSHING
12	1	42N133	LATCH
13	1	42N134	LATCH SPACER
14	1	YBCR24003	BOLT CARRIAGE, 3/4 X 2-1/2 G5
15	1	YNCO12005	NUT HEX, COUPLING, 3/8 X 1-1/8
16	1	YBTE12005	TURNTD EYE BOLT, 3/8 X 1
17	1	42N136	ROPE (18)
18	1	YMSN10005	SNAP HOOK, 5/16
19	2	56N170	PAN WASHER

FIGURE 18

1-3/8 540 RPM CLUTCHED PTO OPTION

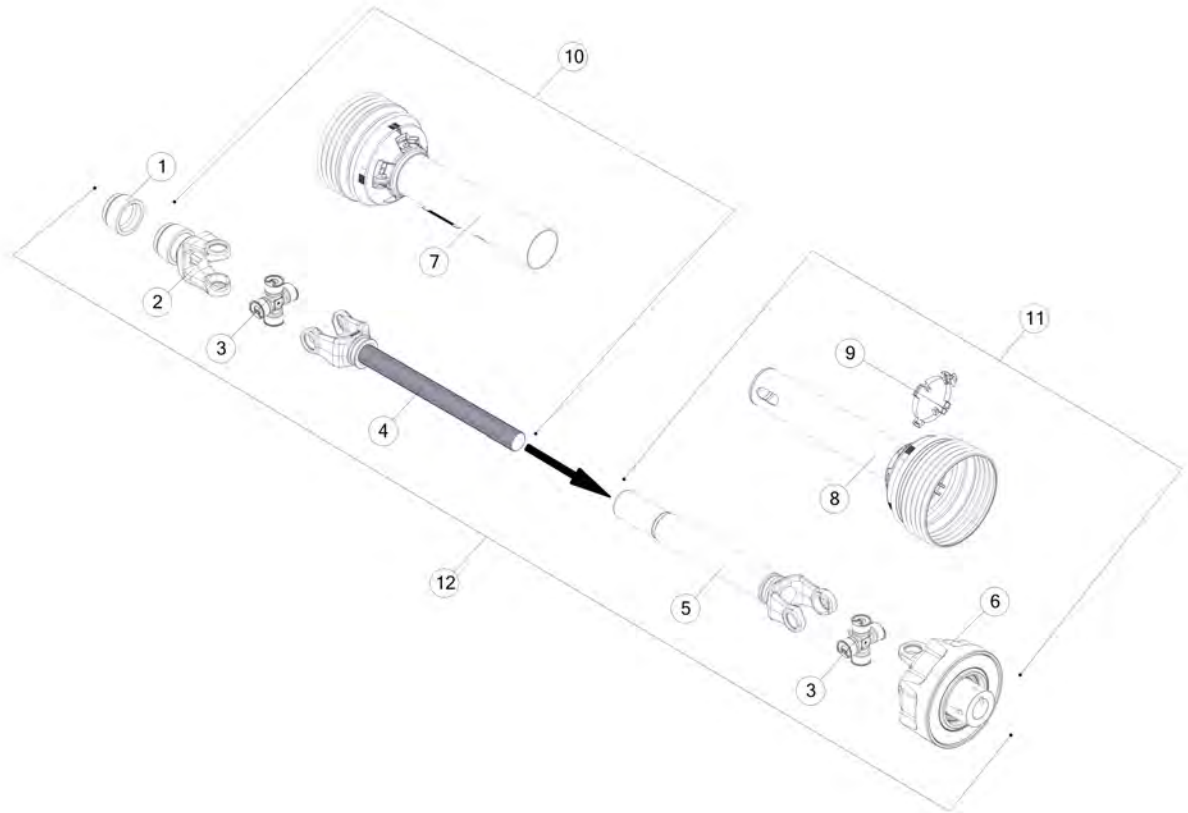

ITEM	PART #	DESCRIPTIONS
1	16SV274	SAFETY SLIDE LOCK REPAIR KIT
2	42N115	LOCK YOKE
3	16SV179	CROSS KIT, 35R
4	61375	YOKE AND SHAFT
5	61378	YOKE AND TUBE
6	61379	PTO CLUTCH
7	61376	OUTER GUARD
8	61377	INNER GUARD
9	16SV383	GUARD REPAIR KIT
10	61371	TRACTOR HALF PTO W/GUARD
11	61373	MACHINE HALF PTO W/GUARD
12	60255	COMPLETE PTO
*	S402	ADMA SAFETY MANUAL

FIGURE 19

1-3/8 1000 RPM CLUTCHED PTO OPTION

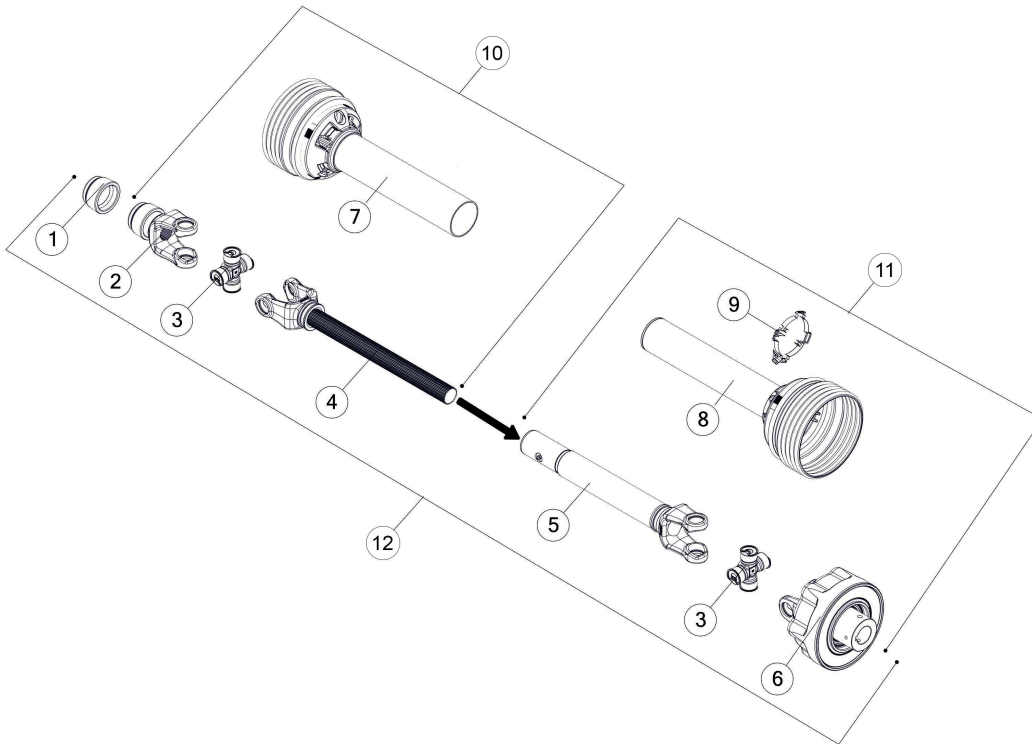

<u>ITEM</u>	<u>PART #</u>	<u>DESCRIPTIONS</u>
1	16SV274	AUTO LOCK REPAIR KIT
2	55N68	AUTO LOCK YOKE
3	16SV179	CROSS KIT, 35R
4	61375	YOKE AND SHAFT
5	61378	YOKE AND TUBE
6	74196	PTO CLUTCH
7	61376	OUTER GUARD
8	61377	INNER GUARD
9	16SV383	ASSY, GUARD REPAIR KIT
10	74400	TRACTOR HALF PTO W/ GUARD
11	74401	MACHINE HALF PTO W/GUARD
12	60422	COMPLETE PTO
*	S402	ADMA SAFETY MANUAL

FIGURE 20

1-3/4 1000 RPM CLUTCHED PTO OPTION

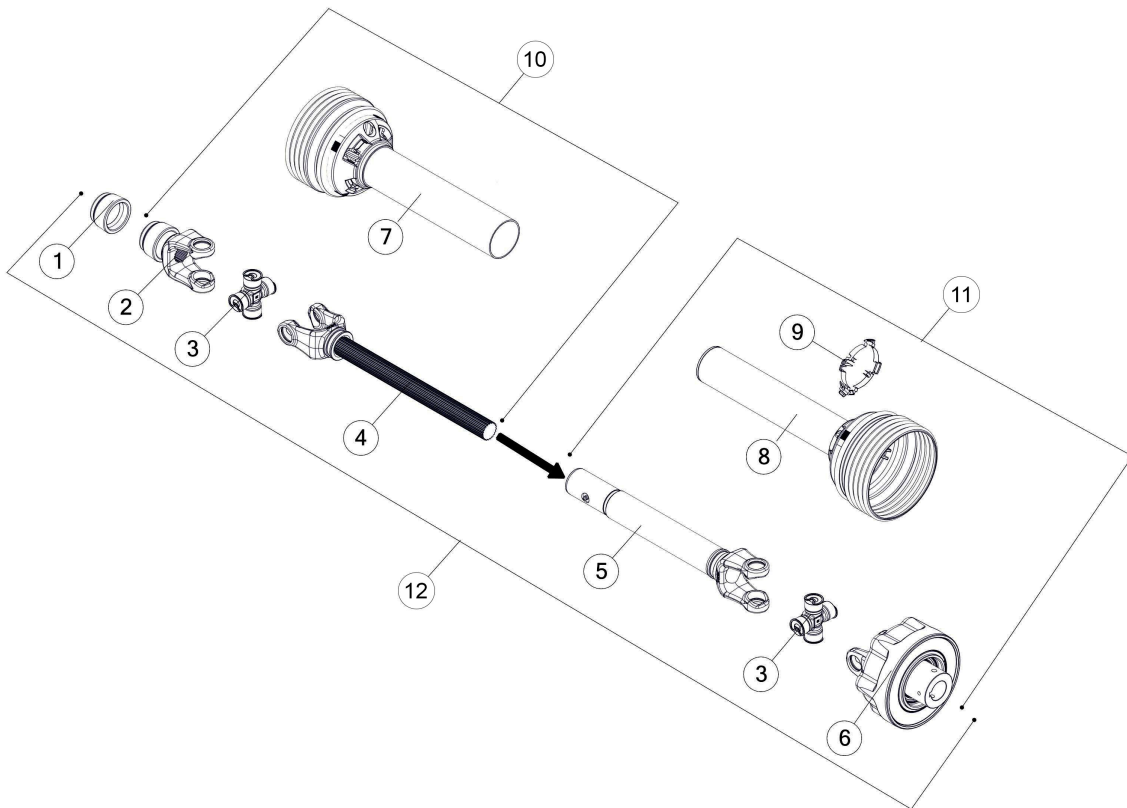

<u>ITEM</u>	<u>PART #</u>	<u>DESCRIPTIONS</u>
1	16SV275	AUTO LOCK REPAIR KIT
2	55N69	AUTO LOCK YOKE
3	16SV179	CROSS KIT, 35R
4	61375	YOKE AND SHAFT
5	61378	YOKE AND TUBE
6	74196	PTO CLUTCH
7	61376	OUTER GUARD
8	61377	INNER GUARD
9	16SV383	GUARD REPAIR KIT
10	74398	TRACTOR HALF PTO W/GUARD
11	74401	MACHINE HALF PTO W/GUARD
12	74390	COMPLETE PTO
*	S402	ADMA SAFETY MANUAL

FIGURE 21

1-3/8 1000 RPM SHEAR BOLT PTO OPTION

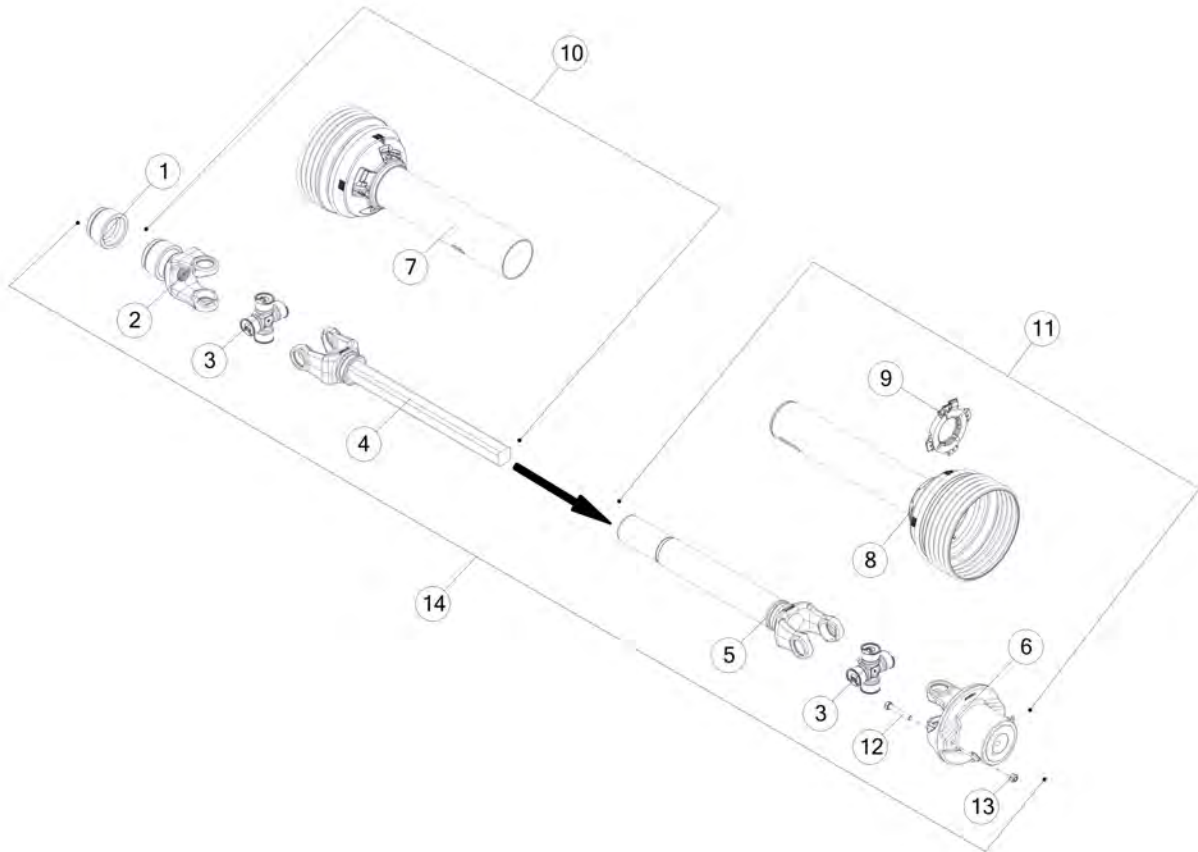

<u>ITEM</u>	<u>PART #</u>	<u>DESCRIPTIONS</u>
1	16SV274	AUTO LOCK REPAIR KIT
2	55N68	AUTO LOCK YOKE
3	16SV179	CROSS KIT, 35R
4	42N116	YOKE AND SHAFT
5	42N119	YOKE, TUBE, SLIP SLEEVE
6	42N120	PTO SHEAR HUB
7	42N117	OUTER GUARD
8	42N118	INNER GUARD
9	16SV181	NYLON REPAIR
10	55N72	TRACTOR HALF PTO W/GUARD
11	55N76	MACHINE HALF PTO W/GUARD
12	YBHH10070	BOLT HEX, 5/16 X 2 G5
13	YNTL10005	NUT HEX, TOP LOCK, 5/16
14	55N78	COMPLETE PTO
*	S402	ADMA SAFETY MANUAL

FIGURE 22

1-3/4 1000 RPM SHEAR BOLT PTO OPTION

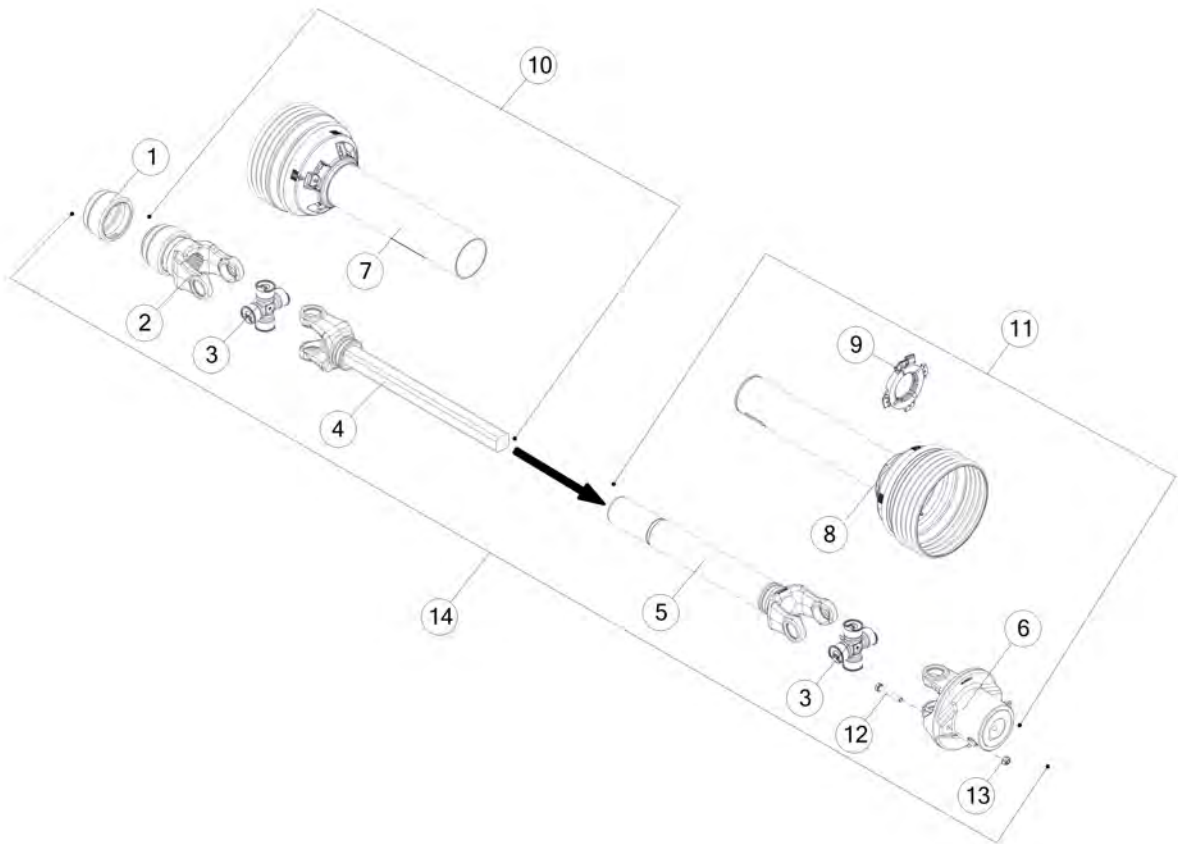

<u>ITEM</u>	<u>PART #</u>	<u>DESCRIPTIONS</u>
1	16SV275	AUTO LOCK REPAIR KIT
2	55N69	AUTO LOCK YOKE
3	16SV179	CROSS KIT, 35R
4	42N116	YOKE AND SHAFT
5	42N119	YOKE, TUBE, SLIP SLEEVE
6	42N120	PTO SHEAR HUB
7	42N117	OUTER GUARD
8	42N118	INNER GUARD
9	16SV181	NYLON REPAIR
10	55N73	TRACTOR HALF PTO W/GUARD
11	55N76	MACHINE HALF PTO W/GUARD
12	YBHH10070	BOLT HEX, 5/16 X 2 G5
13	YNTL10005	NUT HEX, TOP LOCK, 5/16
14	55N79	COMPLETE PTO
*	S402	ADMA SAFETY MANUAL



**H&S Manufacturing products are approved for the
FEMA SEAL OF QUALITY**

**P.O. BOX 768, MARSHFIELD, WI 54449
(715) 387-3414 FAX (715) 384-5463
www.hsmfgco.com**