

H&S PARTS BOOK

HP4155 MANURE SPREADER

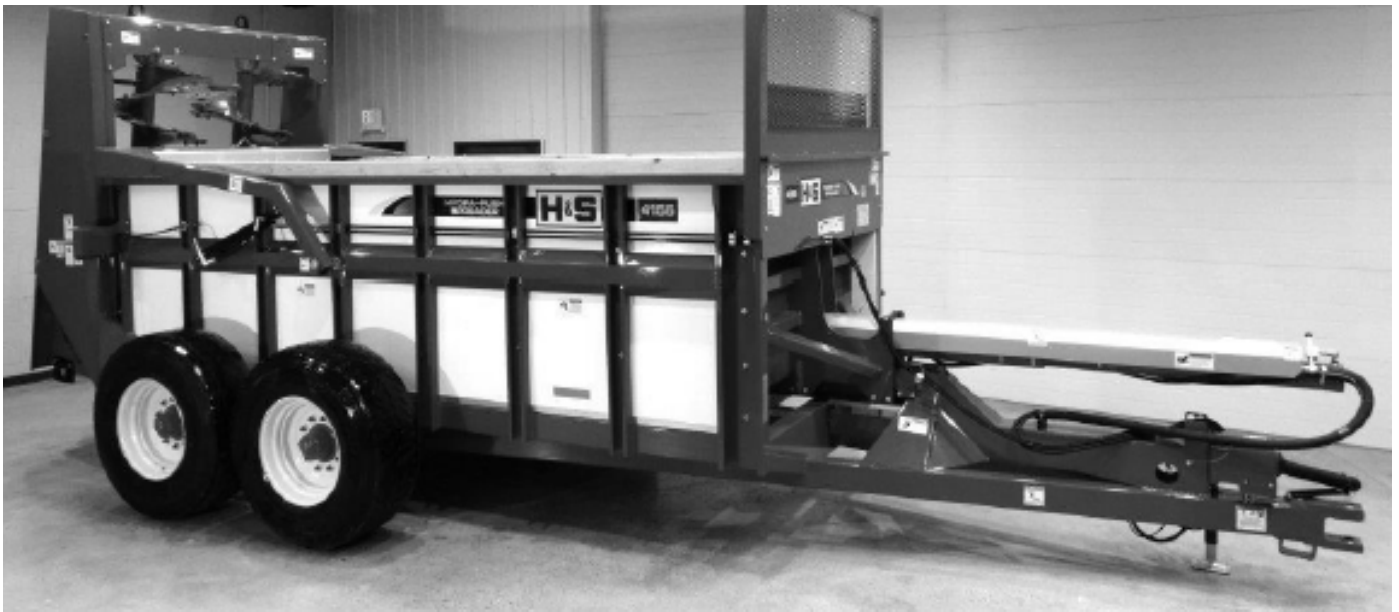

Revision #06

Starting Serial:

HPH4155 - 121HP55002

HPV4155 - 121VP55011

HSMFG011921

PART#72691

Manufactured by
H&S MANUFACTURING CO., INC.
2608 S. HUME AVE. MARSHFIELD, WI 54449
(715) 387-3414 | hsmfgco.com



CONTENTS

Instructions for Ordering Parts - About Improvements	1
Figure 1 - Frame Assembly.	2-3
Figure 2 - Tandem Axle	4-5
Figure 3 - Beater Drive Train.	6-7
Figure 4 - Endgate.	8-9
Figure 5 - Beaters	10-13
Figure 6 - Pusher.	14-15
Figure 7 - Pusher and Endgate Hyd. Components.	16-17
Figure 8 - Endgate Cylinder.	18-19
Figure 9 - Hydraulic pusher Cylinder.	20-21
Figure 10 - Beater Gearbox	22-23
Figure 11 - Vertical Beater Frame.	24-27
Figure 12 - Vertical Beater Drive Train	28-31
Figure 13 - Superior Gearbox Left	32-33
Figure 14 - Superior Gearbox Right	34-35
Figure 15 - Chain Oiler.	36-37
Figure 16 - Optional Lighting	38-39
Figure 17 - Optional Rear Pan	40-41
Figure 18 - 1-3/8 1000 RPM Clutched PTO Option.	42-43
Figure 19 - 1-3/4 1000 RPM Clutched PTO Option.	44-45
Figure 20 - 1-3/8 1000 RPM Clutched Shear Bolt PTO Option	46-47
Figure 21 - 1-3/4 1000 RPM Shear Bolt PTO Option	48-49
Figure 22 - Optional Tandem	50-51
Parts Notes.	52

INSTRUCTIONS FOR ORDERING PARTS

All service parts should be ordered through your authorized H&S dealer. He will be able to give you faster service if you will provide them with the following:

1. Model & Serial Number - Both can be located on front, left side of the PTO bearing support mount.
2. All references to left or right apply to the machine as viewed from the rear.
3. Parts should not be ordered from illustration only. Please order complete part number.
4. If your dealer has to order parts - give shipping instructions:

VIA truck - large pieces (please specify local truck lines)

VIA United Parcel Service (include full address)

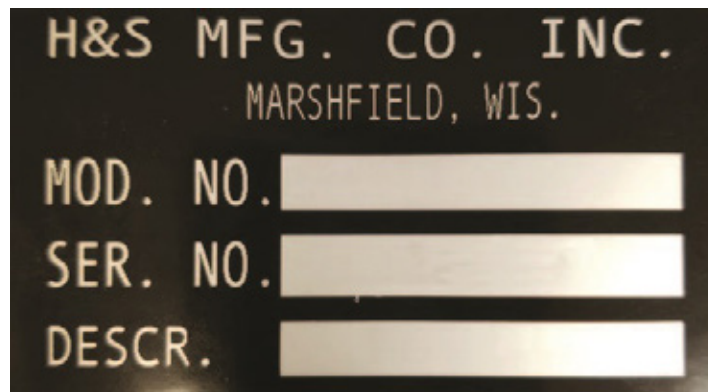

H&S MFG. CO. INC.
MARSHFIELD, WIS.

MOD. NO.

SER. NO.

DESCR.

PLEASE RECORD NUMBERS FOR YOUR UNIT FOR QUICK REFERENCE

ABOUT IMPROVEMENTS

H&S IS CONTINUALLY STRIVING TO IMPROVE ITS PRODUCTS

We must, therefore, reserve the right to make improvements or changes whenever it becomes practical to do so, without incurring any obligation to make changes or additions to the equipment previously sold.

FIGURE 1 FRAME ASSEMBLY

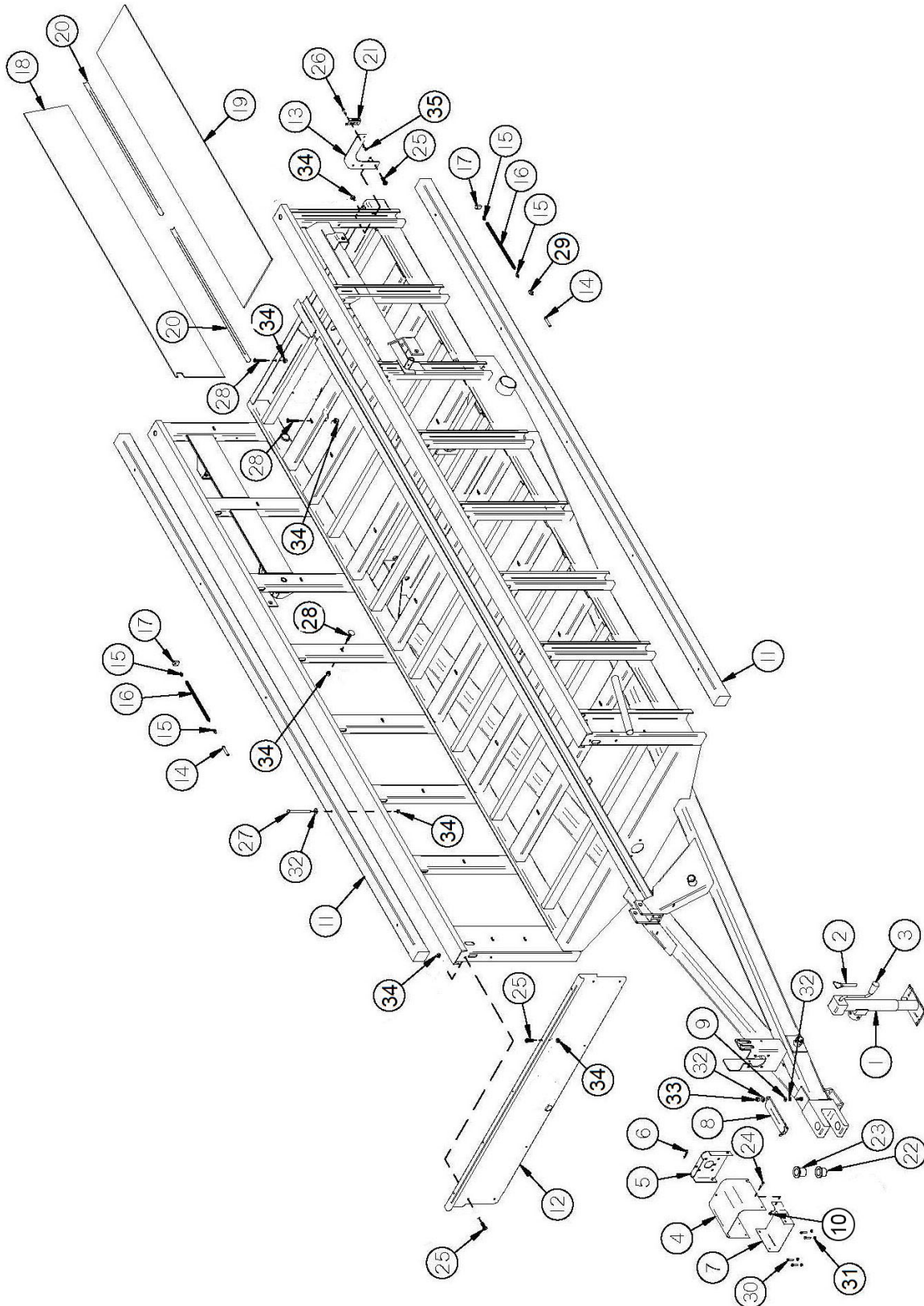

FIGURE 1

FRAME ASSEMBLY

<u>ITEM</u>	<u>QTY</u>	<u>PART#</u>	<u>DESCRIPTION</u>
1	1	27N49	JACK
2	1	27N50	PIN W/CHAIN, 5/8
3	1	12N119	JACK HANDLE
4	1	16SV329	PTO SHIELD
5	1	42N10	SHIELD MOUNT
*	2	YMRV10005	RIVET FLAT HEAD, 5/16 X 1
6	1	YPHR02005	HAIR PIN
7	1	16SV327	SHIELD BOTTOM
8	1	42N2	PTO HOLDER
9	2	42N3	SPRING
10	4	YNFG08010	NUT FLANGE , 1/4 GF
11	2	42N4	WOOD RAIL
12	1	55N1	FRONT PANEL
13	1	42N43	SMV BRACKET
14	1	66077	NIPPLE, 1/8 MALE PIPE X 2-1/2
15	2	S47	GREASE FITTING
16	4	42N41	GREASE LINE
17	2	16V9	GREASE BRACKET
18	2	55N4	SIDE POLY RH
*	1	55N5	SIDE POLY LH
19	1	42N10	FLOOR POLY RH
*	1	42N11	FLOOR POLY LH
20	4	42N12	POLY SIDE ANGLE
21	1	F97	SMV HOLDER
22	1	42N166	HITCH PIN BUSHING BOTTOM (OPTIONAL)
23	1	42N167	HITCH PIN BUSHING TOP (OPTIONAL)
24	4	YBFB08075	BOLT FLANGE, 1/4 X 3/4 G5
25	11	YBFB12003	BOLT FLANGE, 3/8 X 1 G5 ZC
26	2	YBCR10030	BOLT CARRIAGE, 5/16 X 3/4 G5
27	10	YBCR12105	BOLT CARRIAGE, 3/8 X 4-1/2 G5 FULL THREAD
28	58	YSFS12016	FLAT HEAD SOCKET CAP SCREW, 3/8-16 X 1-1/2 ZINC
29	1	66079	HEX ADAPTER, 1/4 FEMALE & 1/8 FEMALE PIPE
30	4	YBHH10070	SHEAR BOLT, 5/16 X 2 G5 (1000 RPM)
31	4	YNRL10005	NUT HEX, REVERSIBLE-SIDE LOCK, 5/16
32	12	YWFL16005	WASHER FLAT, 1/2
33	1	YNFG16003	NUT FLANGE, 1/2 GF
34	98	YNFG12006	NUT FLANGE, 3/8 GF
35	2	YNFG10005	NUT FLANGE, 5/16 GF

***MEANS NOT SHOWN**

FIGURE 2 TANDEM AXLE

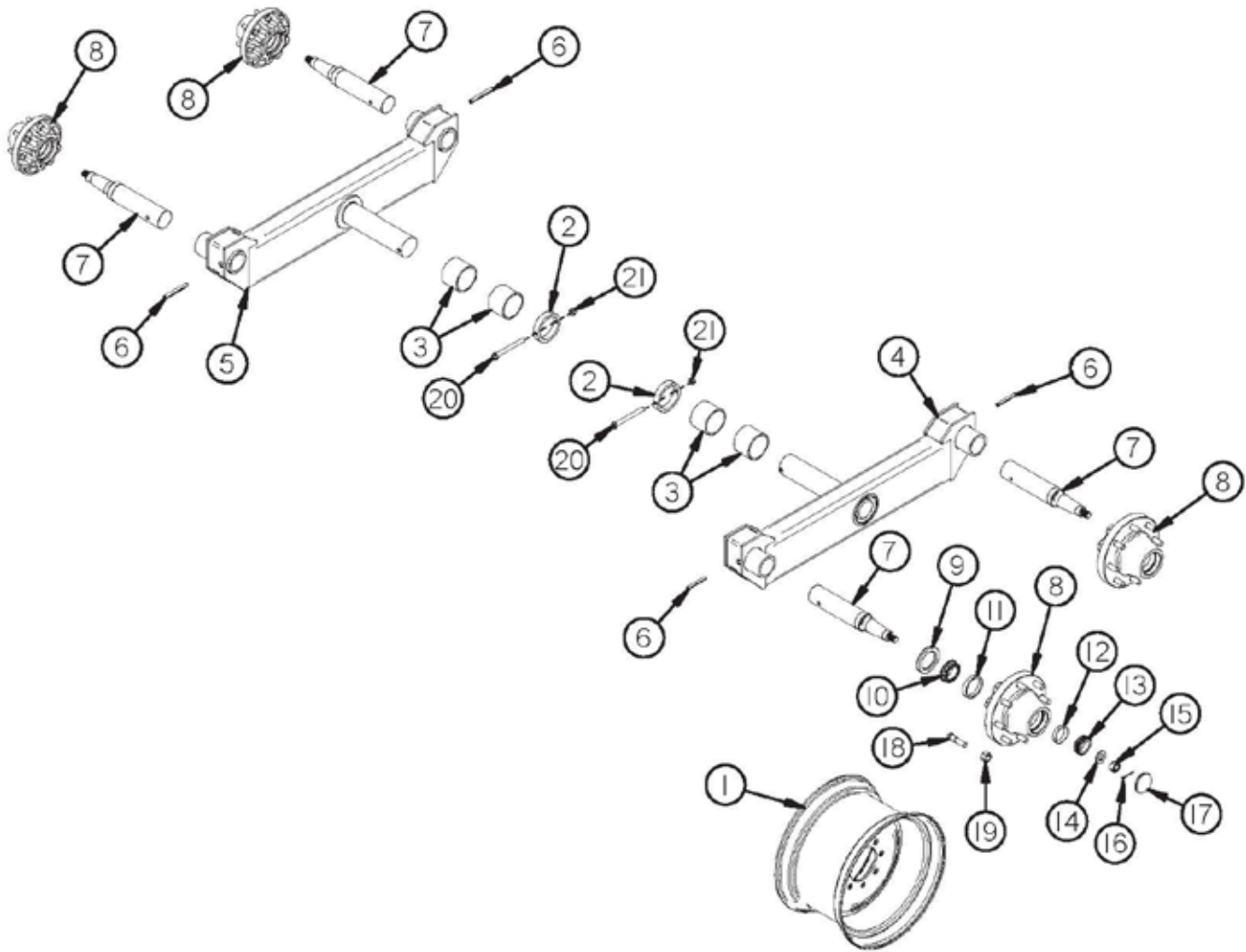

FIGURE 2 TANDEM AXLE

<u>ITEM</u>	<u>QTY</u>	<u>PART#</u>	<u>DESCRIPTION</u>
1	4	60N15	WHEEL, 22.5 X 13.0, 10 BOLT, OFF-WHITE
*	4	16SV88	TIRE 425 X 22.5
2	2	16SV214	AXLE MOUNT
3	4	170157	POLY BUSHING
4	1	55N2	TANDEM AXLE LH
5	1	55N3	TANDEM AXLE RH
6	4	YPEX16020	ROLL PIN
7	4	66N15	TANDEM SPINDLE
8	4	60N8	HUB W/RACES ONLY, (10 BOLT)
9	4	60N5	SEAL
10	4	60N7	INNER BEARING
11	4	60N6	INNER RACE
12	4	60N10	OUTER RACE
13	4	60N9	OUTER BEARING
14	4	60N2	WASHER
15	4	YNCA36005	NUT HEX, CASTLE, 1-1/4
16	4	YPCT07005	COTTER PIN, 7/32 X 2
17	4	60N11	HUB CAP
18	32	YBSD24010	STUD BOLT, 3/4 X 2-3/4 (3/4 SHOULDER)
19	32	YNWL24005	WHEEL NUT, 3/4
20	2	YBHH16165	BOLT HEX, 1/2 X 6 G5
21	2	YNNY16005	NUT HEX, NYLON LOCKNUT, 1/2
*	16	YBHH10020	BOLT HEX, 5/16 X 1/2 G5

***MEANS NOT SHOWN**

FIGURE 3 **BEATER DRIVE TRAIN**

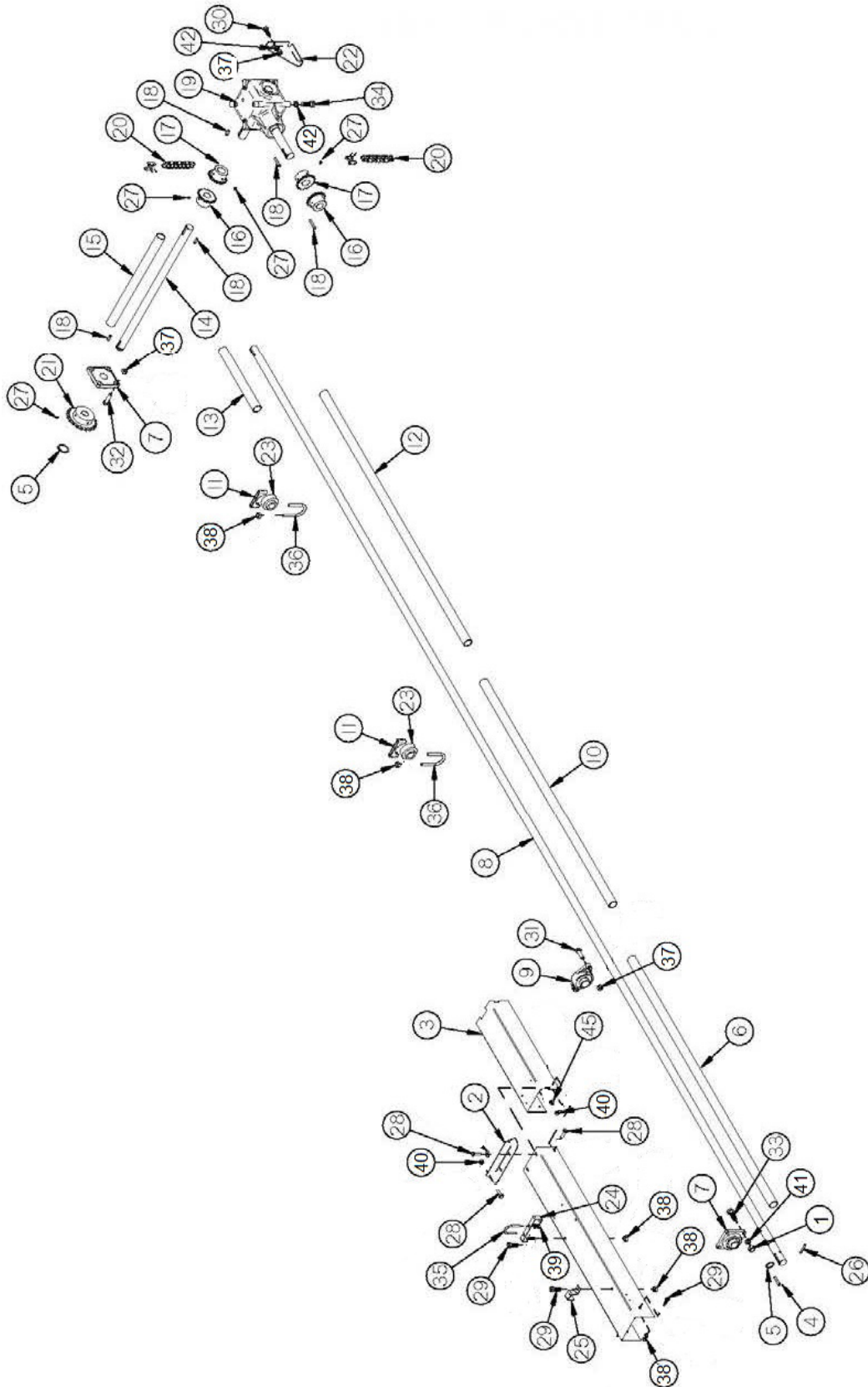

FIGURE 3

BEATER DRIVE TRAIN

<u>ITEM</u>	<u>QTY</u>	<u>PART#</u>	<u>DESCRIPTION</u>
1	4	YNHX18005	NUT HEX , 9/16
2	1	42N14	INPUT SHIELD ANGLE
3	1	42N15	INPUT SHIELD BACK
4	1	S138	KEY W/ROUND ENDS, 3/8 X 2 -3/8
5	2	12V62	SNAP RING
6	1	42N16	INPUT PVC SHIELD
7	2	12V99	BEARING
8	1	42N17	INPUT SHAFT
9	1	42N18	BEARING
10	1	42N19	DRIVE SHAFT CENTER PVC SHIELD
11	2	42N137	BEARING SADDLE
12	1	42N20	DRIVE SHAFT MIDDLE PVC SHIELD
13	1	42N21	DRIVE SHAFT BACK PVC SHIELD
14	1	56783	CROSS SHAFT
15	1	42N23	SHAFT PVC SHIELD
16	2	42N24	SPROCKET (50-B-20)
17	2	42N25	SPROCKET (50-B-20)
18	5	56N174	KEY W/ ROUND END, 3/8 X 2 (HARDENED)
19	1	87267	COMPLETE GEARBOX
20	2	HGV124	CONNECTOR CHAIN (#50) (20P)
21	1	56769	OVER RUNNING CLUTCH
22	1	87278	GEARBOX GUSSET
23	2	42N100	BEARING
24	1	42N101	HOSE HOLDER
25	1	HE14	SMALL PIPE BRACKET
26	1	YPEX12023	EXPANSION PIN, 3/8 X 2-1/2
27	10	YSKP12025	SET SCREW, SOCKET, KNURLED CUP PT, 3/8 X 3/8
28	6	YBFB08100	BOLT FLANGE, 1/4 X 1 G5
29	5	YBFB12003	BOLT FLANGE, 3/8 X 1 G5 ZC
30	2	YBFB16125	BOLT FLANGE, 1/2 X 1-1/4 G5
31	2	YBFB16150	BOLT FLANGE, 1/2 X 1-1/2 G5
32	4	YBFB16175	BOLT FLANGE, 1/2 X 1-3/4 G5
33	4	YBHH18015	BOLT HEX, 9/6 X 2 G5
34	4	YBFB16125	BOLT FLANGE, 1/2 X 1-1/4 G5
35	1	YBPU10007	PIPE U BOLT, 5/16 X 2
36	2	YBPU12025	U-BOLT, 3/8 X 3
37	4	YNFG16003	NUT FLANGE, 1/2 GF
38	8	YNFG12006	NUT FLANGE, 3/8 GF
39	5	YNFG10005	NUT FLANGE, 5/16 GF
40	2	YNFG08010	NUT FLANGE , 1/4 GF
41	4	YWLO18005	WASHER LOCK, 9/16
42	4	YWLO16005	WASHER LOCK, 1/2

FIGURE 4
ENDGATE

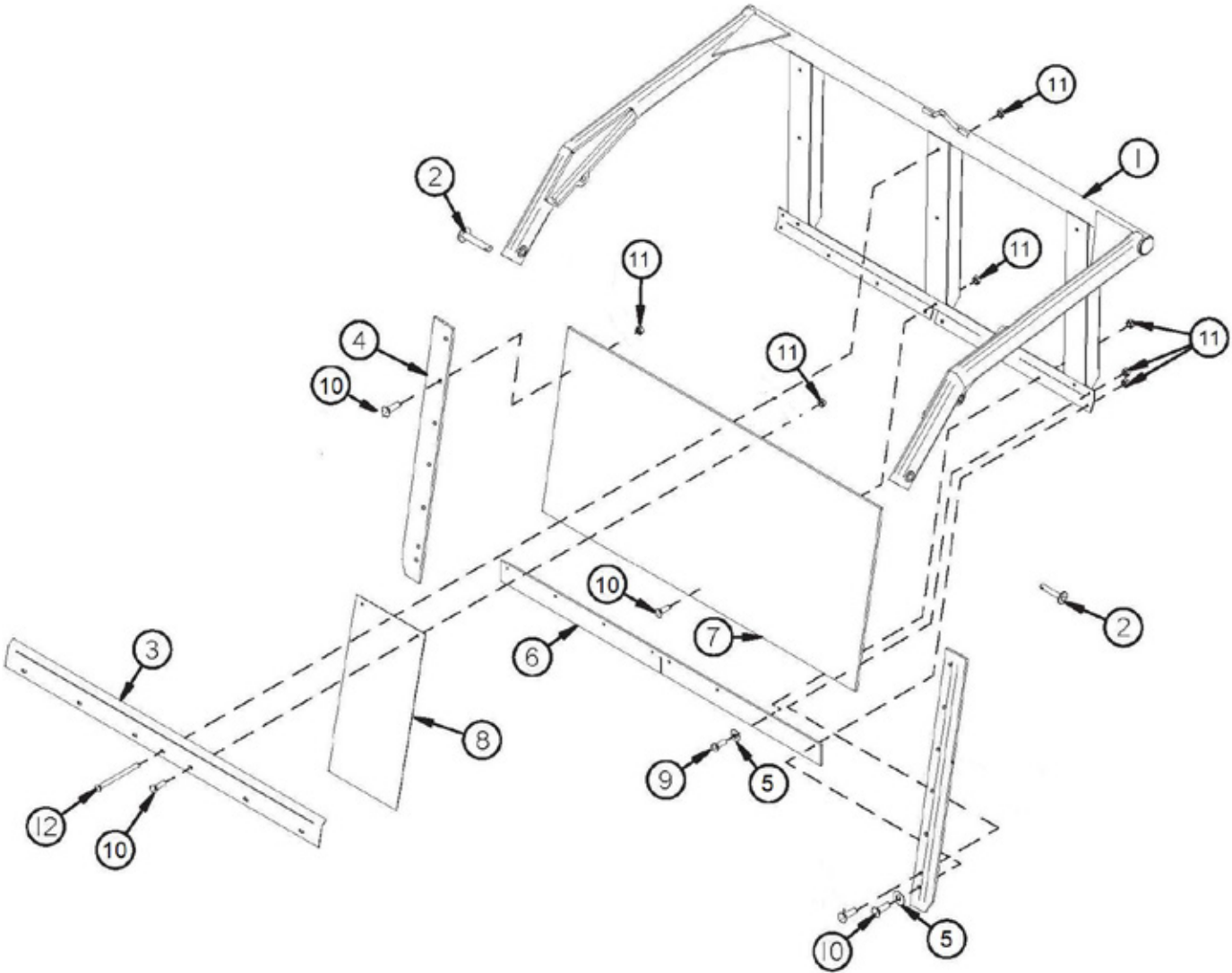

FIGURE 4 **ENDGATE**

<u>ITEM</u>	<u>QTY</u>	<u>PART#</u>	<u>DESCRIPTION</u>
1	1	55N9	ENDGATE
2	2	55N10	HINGE PIN
3	1	55N11	ENDGATE POLY HOLDOWN
4	2	55N13	ENDGATE RUBBER LH
5	36	YWFL16005	WASHER FLAT, 1/2
6	1	55N14	ENDGATE RUBBER
7	1	55N15	ENDGATE POLY
8	5	55N88	ENDGATE CURTAIN
9	23	YBCR12010	BOLT CARRIAGE, 3/8 X 1 G5
10	18	YBCR12015	BOLT CARRIAGE, 3/8 X 1-1/2 G5
11	57	YNFG12006	NUT FLANGE, 3/8 GF
12	16	YBCR12105	BOLT CARRIAGE, 3/8 X 4-1/2 G5

FIGURE 5 **HORIZONTAL BEATER ASSEMBLY**

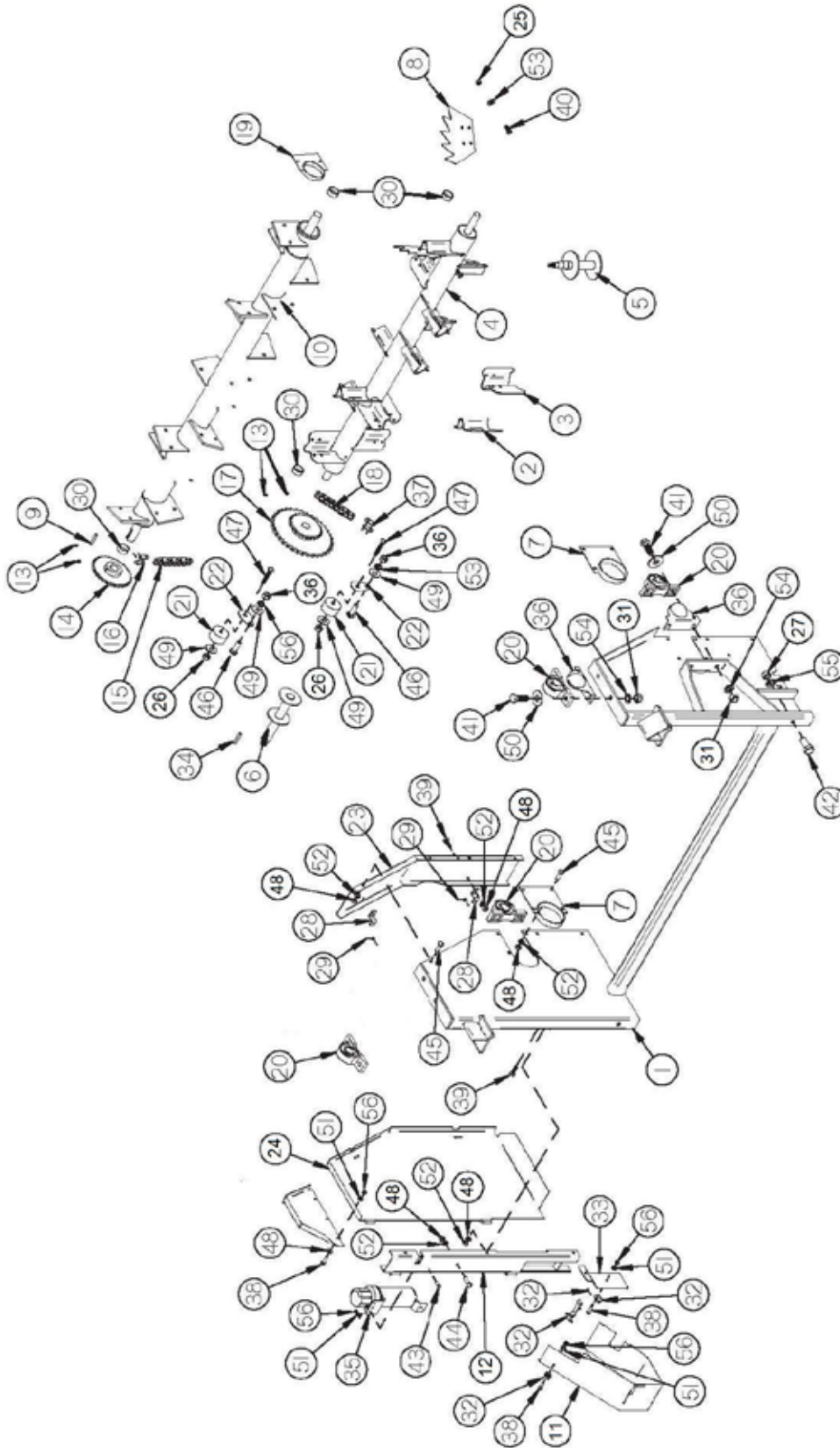

FIGURE 5

HORIZONTAL BEATER ASSEMBLY

<u>ITEM</u>	<u>QTY</u>	<u>PART#</u>	<u>DESCRIPTION</u>
1	1	55N16	BEATER PANEL
2	12	42N36	BLADER HOLDER RH
3	12	42N37	BLADE HOLDER LH
4	2	42N38	BEATER PANEL
5	2	56N69	BEATER STUB SHAFT
6	2	42N39	BEATER DRIVE SHAFT
7	2	42N40	BEATER SLOT FILLER
8	24	23N277	BEATER BLADE
9	1	56N174	KEY, 3/8 X 2
10	1	42N42	SECOND BEATER
11	4	42N56	CROSS SHAFT SHIELD
12	1	55N22	SHIELD FILLER
13	1	YSKP12025	SET SCREW, SOCKET, KNURLED CUP PT, 3/8 X 3/8
14	4	16SV213	SECOND BEATER SPROCKET (80-B-23)
15	1	55N17	SECOND BEATER CHAIN (#80) (82P)
16	1	F157	CONNECTOR LINK (#80)
17	1	55N19	BEATER SPROCKET (#80-36T-#80-20T) (1000)
18	1	42N48	BEATER CHAIN (#80) (88P) (1000)
19	1	55N18	SECOND BEATER SLOT FILLER
20	1	16SV72	PILLOW BLOCK BEARING
21	4	42N50	POLY CHAIN TIGHTENER
22	2	42N51	TIGHTENER STOP
23	2	55N20	MAIN PANEL RH
24	1	55N21	MAIN PANEL RH
25	96	YNTL16005	NUT HEX, TOP LOCK, 1/2
26	2	YNRL16005	NUT HEX, REVERSIBLE-SIDE LOCK, 1/2
27	2	YNHX24005	NUT HEX, 3/4
28	2	F69	SHIELD BRACKET
29	2	YPLY08011	LYNCH PIN, 1/4 X 1-9/16
30	4	42N103	BEATER SPACER
31	8	YNHX18005	NUT HEX , 9/16
32	1	X233	COMPLETE LATCH
33	1	42N105	BACK STAKE FILLER
34	1	42N141	KEY W/ ROUND ENDS, 3/8 X 2-1/4
35	1	S522	MANUAL HOLDER
36	2	YNHX16005	NUT HEX, 1/2
37	1	F157	CONNECTOR LINK (#80)
38	5	YBHH08010	BOLT HEX, 1/4 X 1 G5
39	5	YBHH12010	BOLT HEX, 3/8 X 1 G5
40	80	YBHH16045	BOLT HEX, 1/2 X 1-1/4 G5
41	8	YBHH18015	BOLT HEX, 9/16 X 2 G5
42	2	YBHH24010	BOLT HEX, 3/4 X 1-1/2 G5
43	3	YSTM08004	SCREW SLOTTED TRUSS HEAD, MACHINE, 1/4 X 3/4
44	1	YBCR12065	BOLT CARRIAGE, 3/8 X 3/4 G5
45	11	YBCR12010	BOLT CARRIAGE, 3/8 X 1 G5

FIGURE 5 **HORIZONTAL BEATER ASSEMBLY**

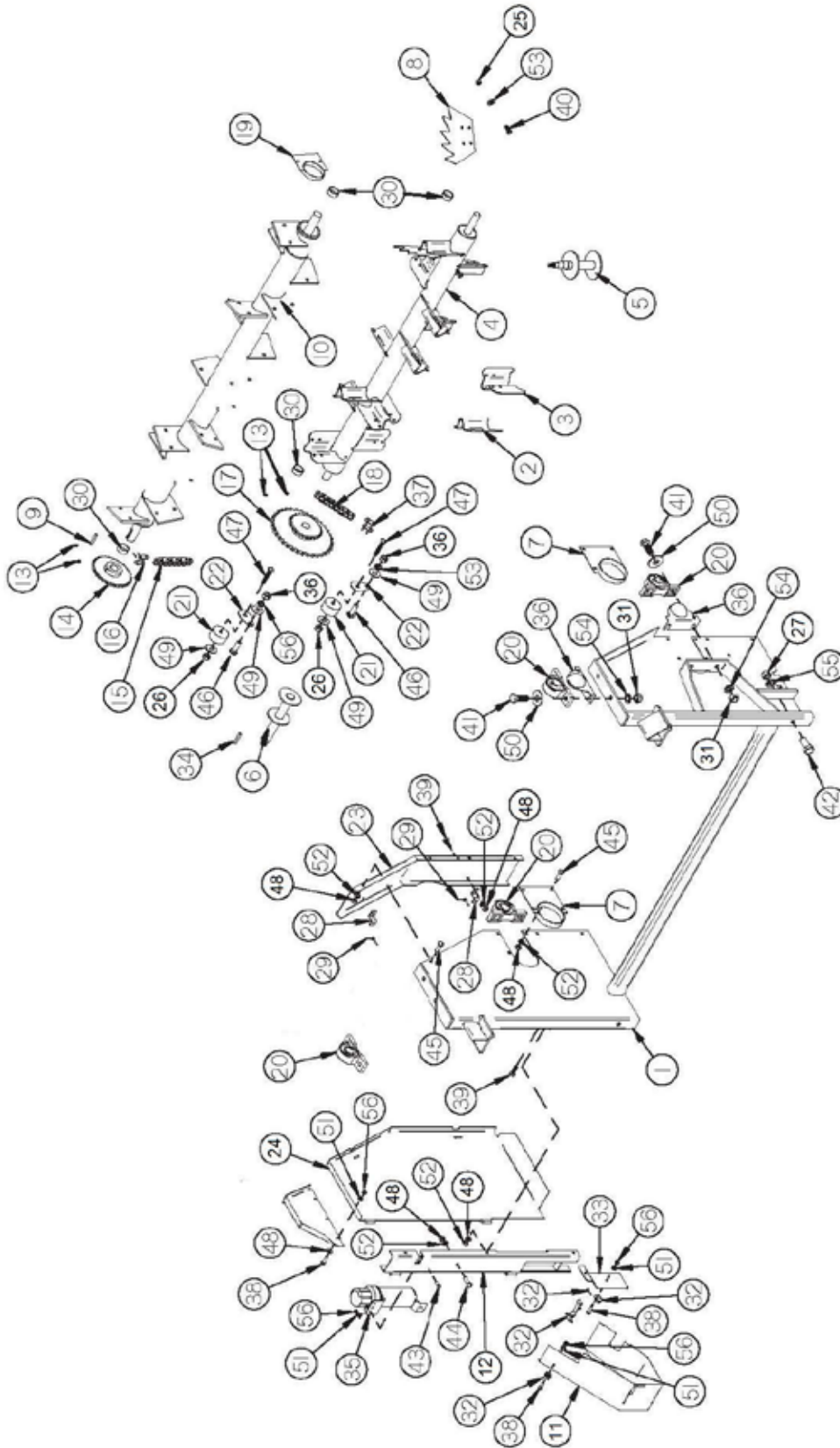

FIGURE 5
HORIZONTAL BEATER ASSEMBLY

<u>ITEM</u>	<u>QTY</u>	<u>PART#</u>	<u>DESCRIPTION</u>
46	2	YBCR16015	BOLT CARRIAGE, 1/2 X 1-1/4 G5
47	2	YBCR16035	BOLT CARRIAGE, 1/2 X 2-3/4 G5
48	17	YNHX12005	NUT HEX, 3/8
49	4	YWFL16005	WASHER FLAT, 1/2 USS
50	8	YWFL18005	WASHER FLAT, 9/16 USS
51	8	YWLO08005	WASHER LOCK, 1/4
52	17	YWLO12005	WASHER LOCK, 3/8
53	82	YWLO16005	WASHER LOCK, 1/2
54	8	YWLO18005	WASHER LOCK, 9/16
55	2	YWLO24005	WASHER LOCK, 3/4
56	8	YNHX08005	NUT HEX , 1/4

FIGURE 6 **PUSHER**

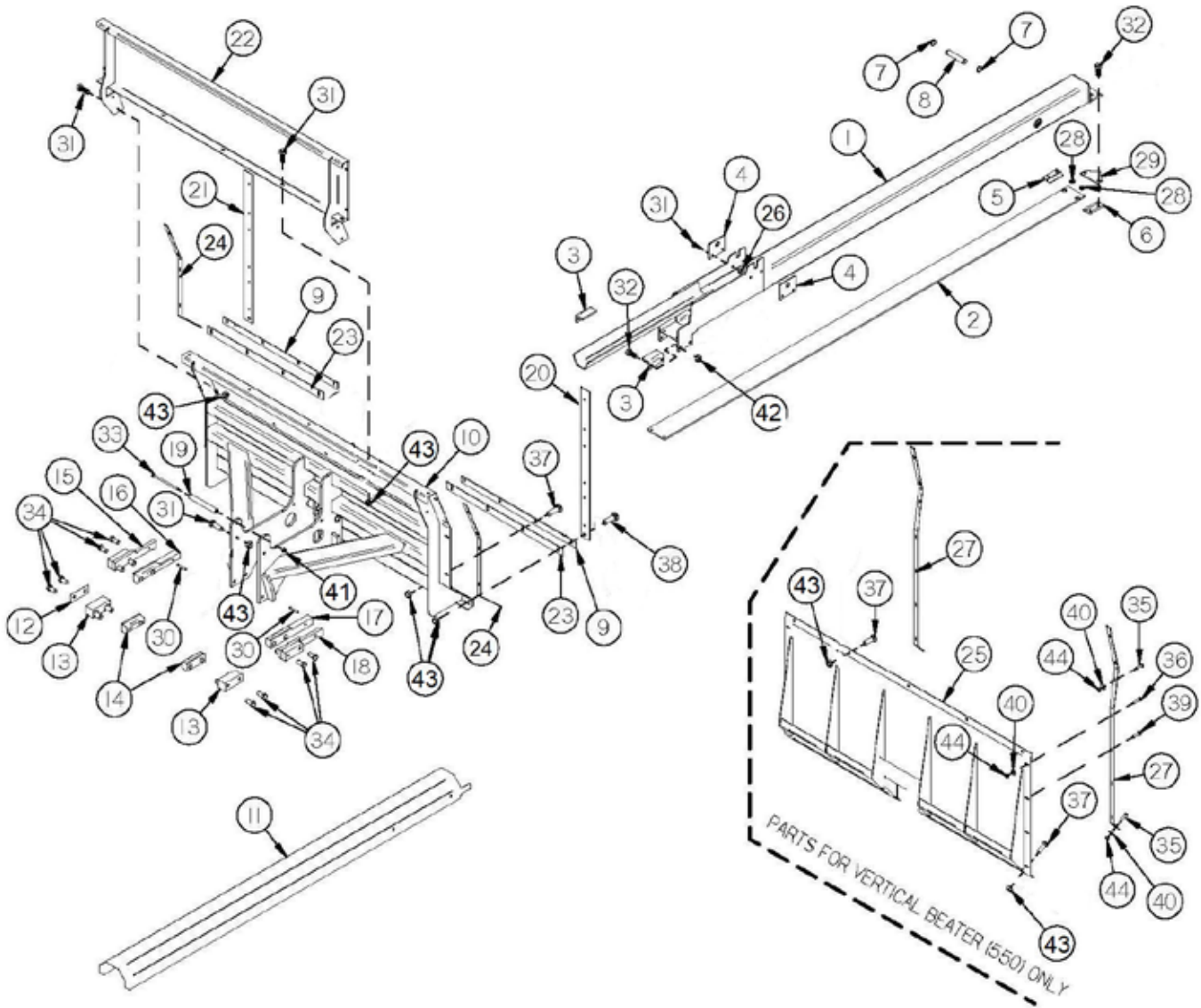

FIGURE 6 PUSHER

<u>ITEM</u>	<u>QTY</u>	<u>PART#</u>	<u>DESCRIPTION</u>
1	1	55N44	MOVEABLE FLOOR TUBE
2	1	55N85	PUSHER SLIDE TUBING
3	2	55N46	FRONT PUSHER TUBE GUIDE
4	2	55N47	CYLINDER RETAINER
5	1	55N48	END CAP CLAMP RH
6	1	55N49	END CAP CLAMP LH
7	2	F73	SNAP RING, 1
8	1	55N50	REAR CYLINDER PIN
9	2	55N81	PUSHER WIPER
10	1	55N26	PUSHER
11	1	55N51	CYLINDER SHIELD
12	A/R	42N114	PUSHER SHIM
13	2	55N52	POLY BLOCK SPACER
14	2	55N53	PUSHER POLY SLIDE
15	1	55N54	POLY BLOCK SPACER RH
16	1	55N55	PUSHER POLY SLIDE RH
17	1	55N56	PUSHER POLY SLIDE LH
18	1	55N57	POLY BLOCK SPACER LH
19	1	55N59	PUSHER SPACER
20	1	55N27	PUSHER RUBBER LH
21	1	55N28	PUSHER RUBBER RH
22	1	79355	PUSHER EXTENSION
23	2	55N83	BOTTOM PUSHER RUBBER
24	2	55N25	RUBBER STRAP
25	1	HGV113	FLAT PUSHER FACE
26	4	YNFG12006	NUT FLANGE, 3/8 GF
27	4	HGV114	FLAT PUSHER SEAL STRAP
28	2	42N150	POLY SPACER
29	1	55N86	SCRAPER
30	2	YPEX12023	EXPANSION PIN, 3/8 X 2-1/2
31	17	YBFB12125	BOLT FLANGE, 3/8 X 1-1/4 G5
32	8	YBFB16125	BOLT FLANGE, 1/2 X 1-1/4 G5
33	1	YBHH16200	BOLT HEX, 1/2 X 10 G5
34	8	YBFB20125	BOLT FLANGE, 5/8 X 1-1/4 G5
35	8	YBCR08005	BOLT CARRIAGE, 1/4 X 1 G5
36	2	YBCR08010	BOLT CARRIAGE, 1/4 X 1-1/2 G5
37	19	YBCR12010	BOLT CARRIAGE, 3/8 X 1 G5
38	2	YBCR12015	BOLT CARRIAGE, 3/8 X 1-1/2 G5
39	6	YSHW10010	HEX WASHER SLOT, 1-1/4
40	10	YWFL08005	WASHER FLAT, 1/4
41	1	YNNY16005	NUT HEX, NYLON LOCKNUT, 1/2
42	4	YNFG16003	NUT FLANGE, 1/2 GF
43	34	YNFG12006	NUT FLANGE, 3/8 GF
44	10	YNHX08005	NUT HEX, 1/4

A/R MEANS AS REQUIRED

FIGURE 7 PUSHER & ENDGATE HYD. COMPONENTS

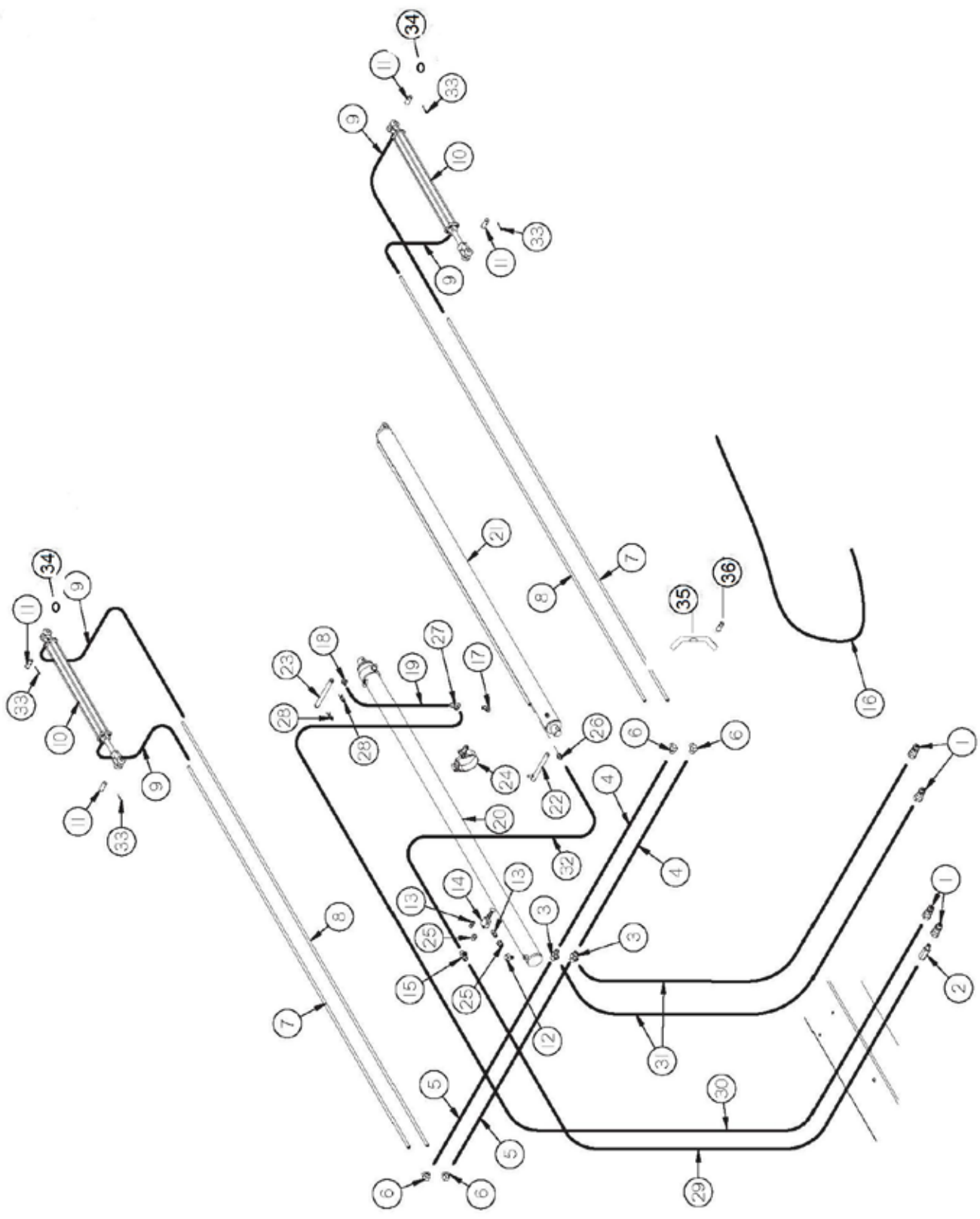

FIGURE 7

PUSHER & ENDGATE HYD. COMPONENTS

<u>ITEM</u>	<u>QTY</u>	<u>PART#</u>	<u>DESCRIPTION</u>
1	4	DWM205	MALE QUICK COUPLER
2	1	57735	CHECK VALVE
3	2	BFR74	TEE
4	2	46N40	HYD HOSE, 3/8 X 46
5	2	BFR287	HYD HOSE, 3/8 X 36
6	4	HE59	FEMALE ELBOW, 3/8
7	2	55N23	ENDGATE HYD LINE SHORT
8	2	55N24	ENDGATE HYD LINE LONG
9	4	12V19	HYD HOSE, 3/8 X 24
10	2	56002	HYDRAULIC CYLINDER, (2 X 20)
11	4	56N141	CYLINDER PIN
12	1	HE58	FITTING, 1/2 NPT X 1/2 NPT, 90 DEGREE
13	2	16SV351	NIPPLE, 3/8
14	1	16SV339	SEQUENCE VALVE
15	1	DF8	TEE, 1/2 NPT X 1/2 NPT X 1/2 NPT
16	1	42N64	HOSE SHIELD
17	1	55N65	UNION ADAPTER, 1/2, 45 DEGREE
18	1	HE58	FITTING, 1/2 NPT X 1/2 NPT, 90 DEGREE
19	1	16SV143	HYD HOSE, 1/2 X 19
20	1	55N32	HYD CYLINDER, (4-1/2 X 90 X 2-1/2)
21	1	55N33	HYD CYLINDER, (4-1/2 X 90 X 2-1/2)
22	1	55N34	CYLINDER PIN
23	1	55N35	PUSHER CYLINDER PIN
24	1	55N66	HOSE CLAMP
25	2	JB82	BUSHING, 1/2 TO 3/8
26	1	MA12	MALE ADAPTER UNION, 1/2
27	1	WM139	SERVICE TEE, 1/2
28	2	T144	CLIP PIN
29	1	HGV165	HYD HOSE, 1/2 X 186
30	1	HGV166	HYD HOSE, 1/2 X 260
31	2	HGV167	HYD HOSE, 3/8 X 157
32	1	55N30	HYD HOSE, 1/2 X 76
33	4	YPCT07005	COTTER PIN, 7/32 X 2
34	2	K132	SPACER, 3/8
35	7	23N67	TAILGATE HOSE BRACKET
36	7	YNFG12006	NUT FLANGE, 3/8 GF

FIGURE 8
ENDGATE CYLINDER

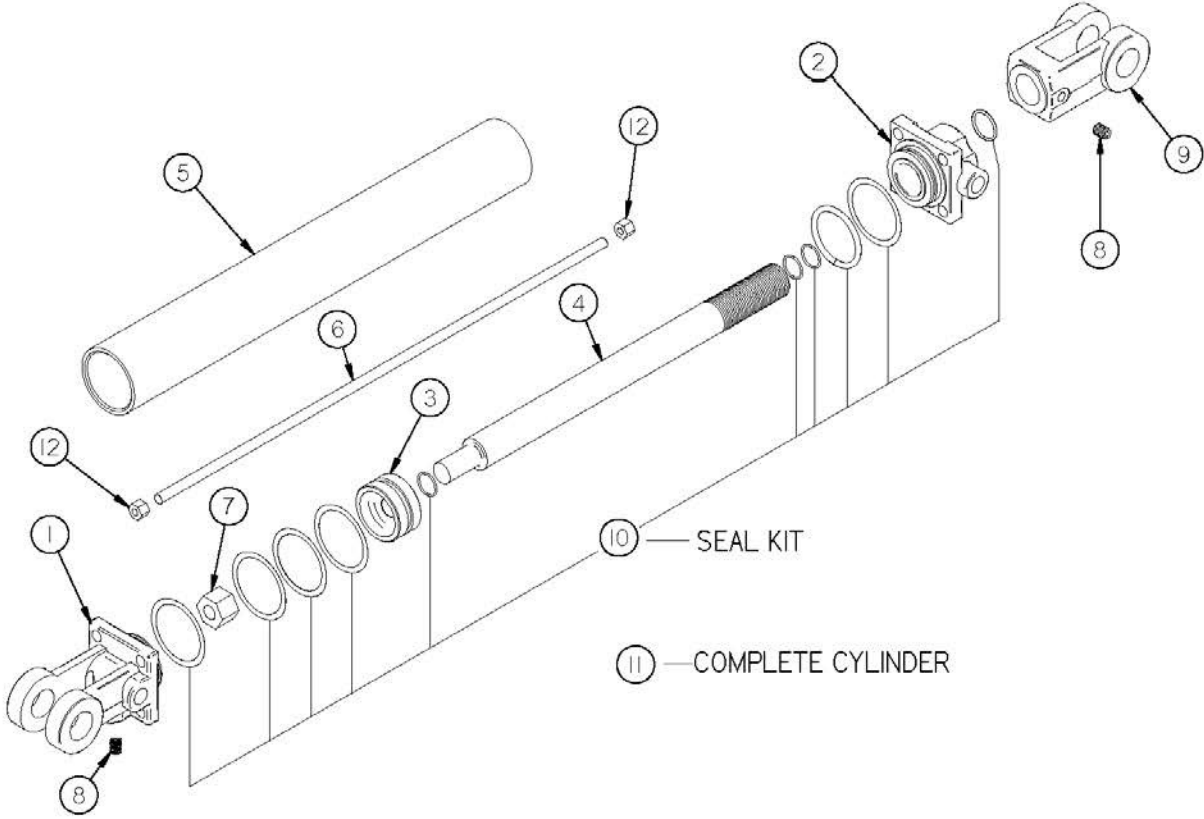

FIGURE 8
ENDGATE CYLINDER

<u>ITEM</u>	<u>QTY</u>	<u>PART#</u>	<u>DESCRIPTION</u>
1	1	23N142A	CLEVIS CAP
2	1	56174	ROD CAP
3	1	56180	PISTON
4	1	45N42	ROD CAP
5	1	45N43	CYLINDER TUBE
6	4	45N44	TIE ROD
7	1	23N148	PISTON NUT
8	2	23N149	PLUG
9	1	23N150A	ROD CLEVIS
10	1	56187	SEAL KIT
11	1	56002	HYDRAULIC CYLINDER
12	8	YNHX12005	NUT HEX, 3/8

FIGURE 9
HYDRAULIC PUSHER CYLINDER

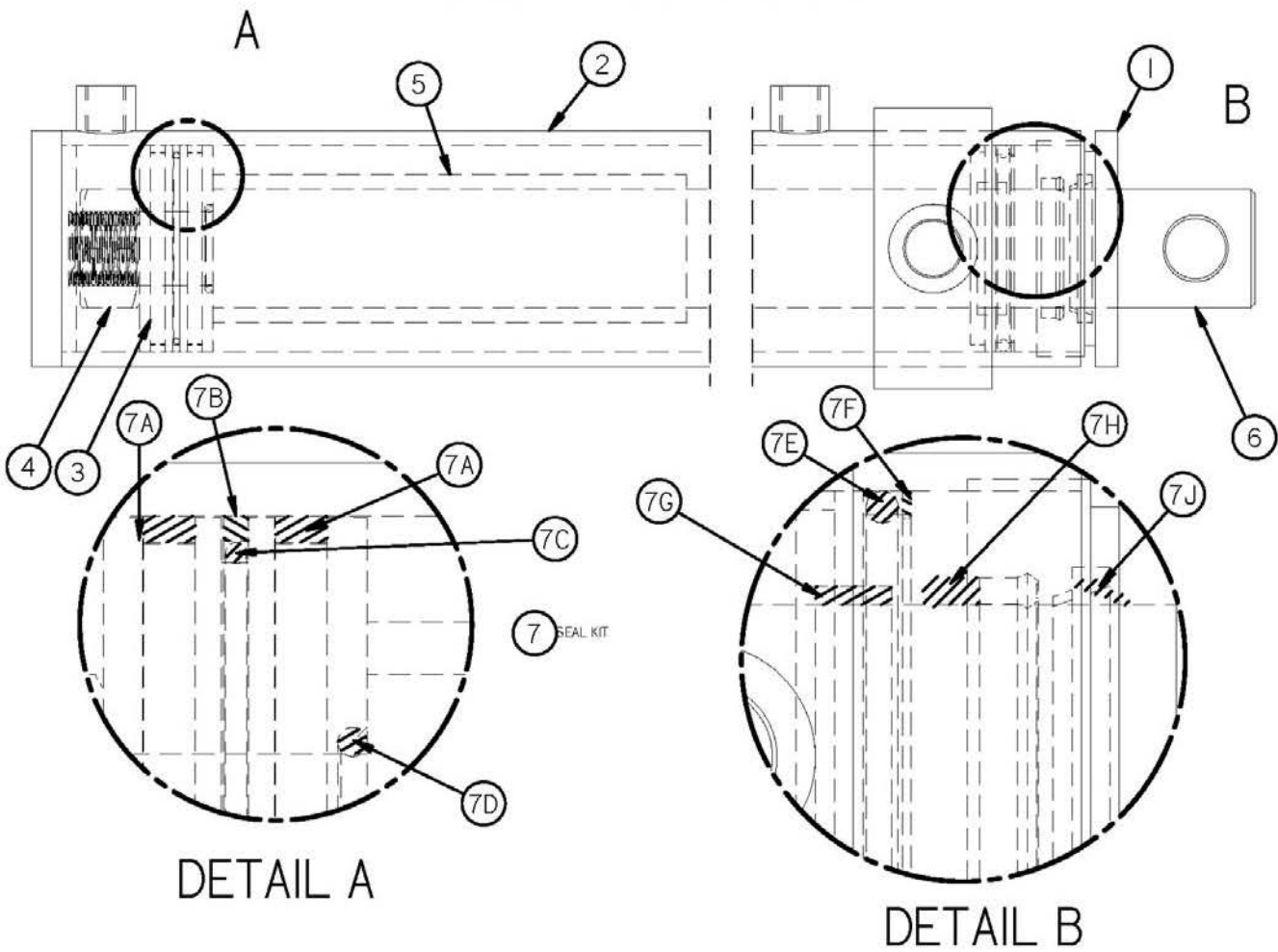

FIGURE 9 HYDRAULIC PUSHER CYLINDER

<u>ITEM</u>	<u>QTY</u>	<u>PART#</u>	<u>DESCRIPTION</u>
1	1	55N36	INTERNAL HEAD
2	1	55N37	BARREL ASSM (TOP CYL)
*	1	55N38	BARREL ASSM (BOTTOM CYL)
3	1	55N39	PISTON
4	1	55N40	LOCKNUT
5	1	55N41	SPACER
6	1	55N42	ROD
7	1	55N43	SEAL KIT (INC ITEMS 7A THRU 7J)
7A	2	"	WEAR RING
7B	1	"	P
7C	1	"	O-RING
7D	1	"	O-RING
7E	1	"	O-RING
7F	1	"	BACK-UP RING
7G	1	"	WEAR RING
7H	1	"	LOADED U-CUP
7J	1	"	ROD WIPER
*	1	55N32	COMP. CYL. - TOP
*	1	55N33	COMP. CYL. - BOTTOM

***MEANS NOT SHOWN**

FIGURE 10
BEATER GEARBOX

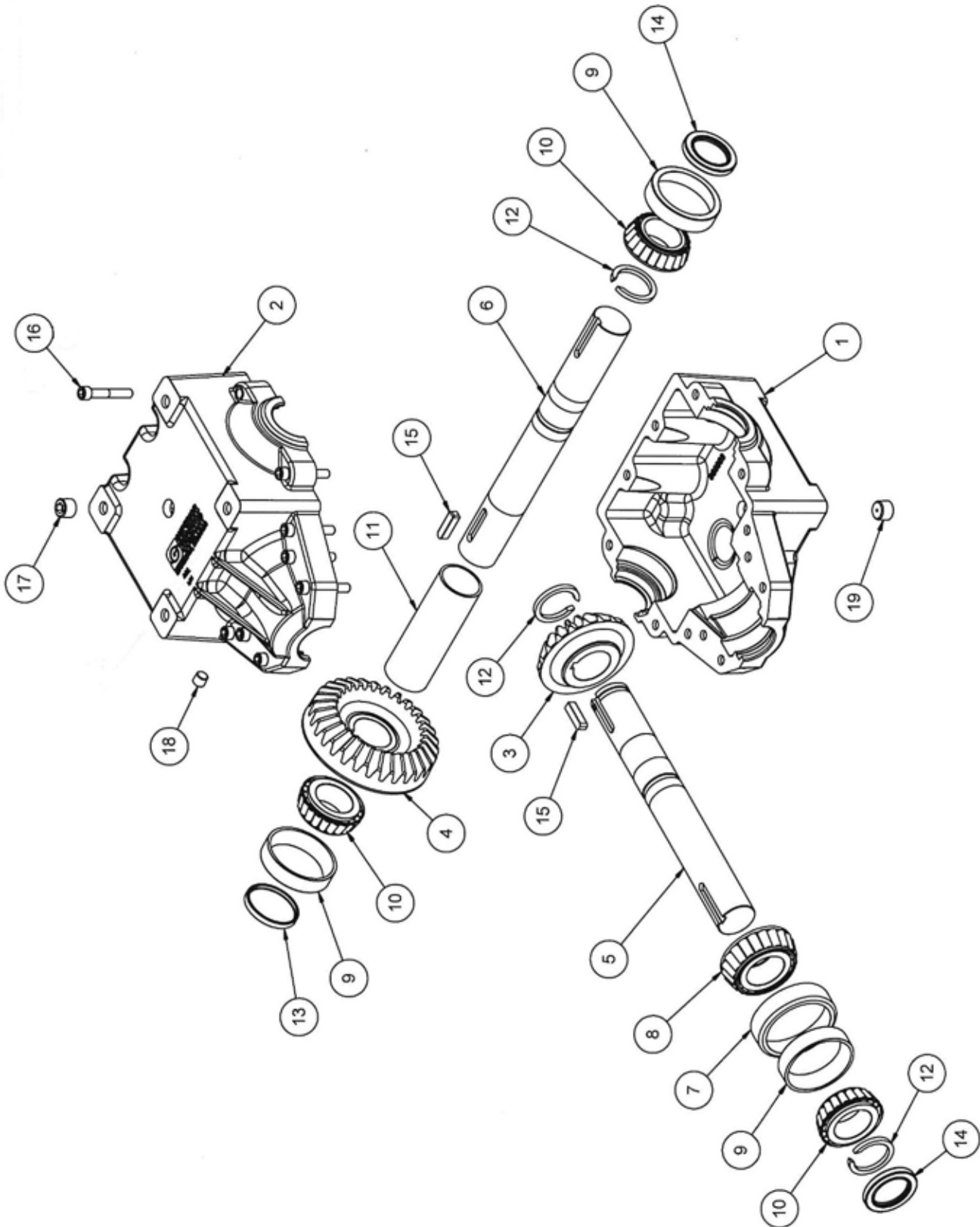

FIGURE 10

BEATER GEARBOX

<u>ITEM</u>	<u>QTY</u>	<u>PART#</u>	<u>DESCRIPTION</u>
1	1	HGV88	BOTTOM HOUSING
2	1	88365	HOUSING
3	1	88366	GEAR
4	1	88367	GEAR
5	1	88368	STUB SHAFT
6	1	88369	CROSS SHAFT
7	1	HGV112	BEARING CUP
8	1	HGV97	BEARING CONE
9	3	HGV92	BEARING CUP
10	3	HGV91	BEARING CONE
11	1	88370	SPACER
12	3	HGV98	RETAINING RING
13	1	HGV99	CAP
14	2	HGV93	OUTPUT SEAL
15	2	A32	SQUARE KEY W/ ROUND ENDS, 3/8 X 1-3/8
16	12	YSHS12012	SCREW SOCKET HEAD CAP, 3/8 X 2-1/4 G8
17	1	HGV95	PLUG, 1/2 NPT
18	1	88371	LEVEL PLUG
19	1	88372	VENT PLUG
*	1	87267	COMPLETE GEARBOX

FIGURE 11
VERTICAL BEATERS FRAME ASSEMBLY

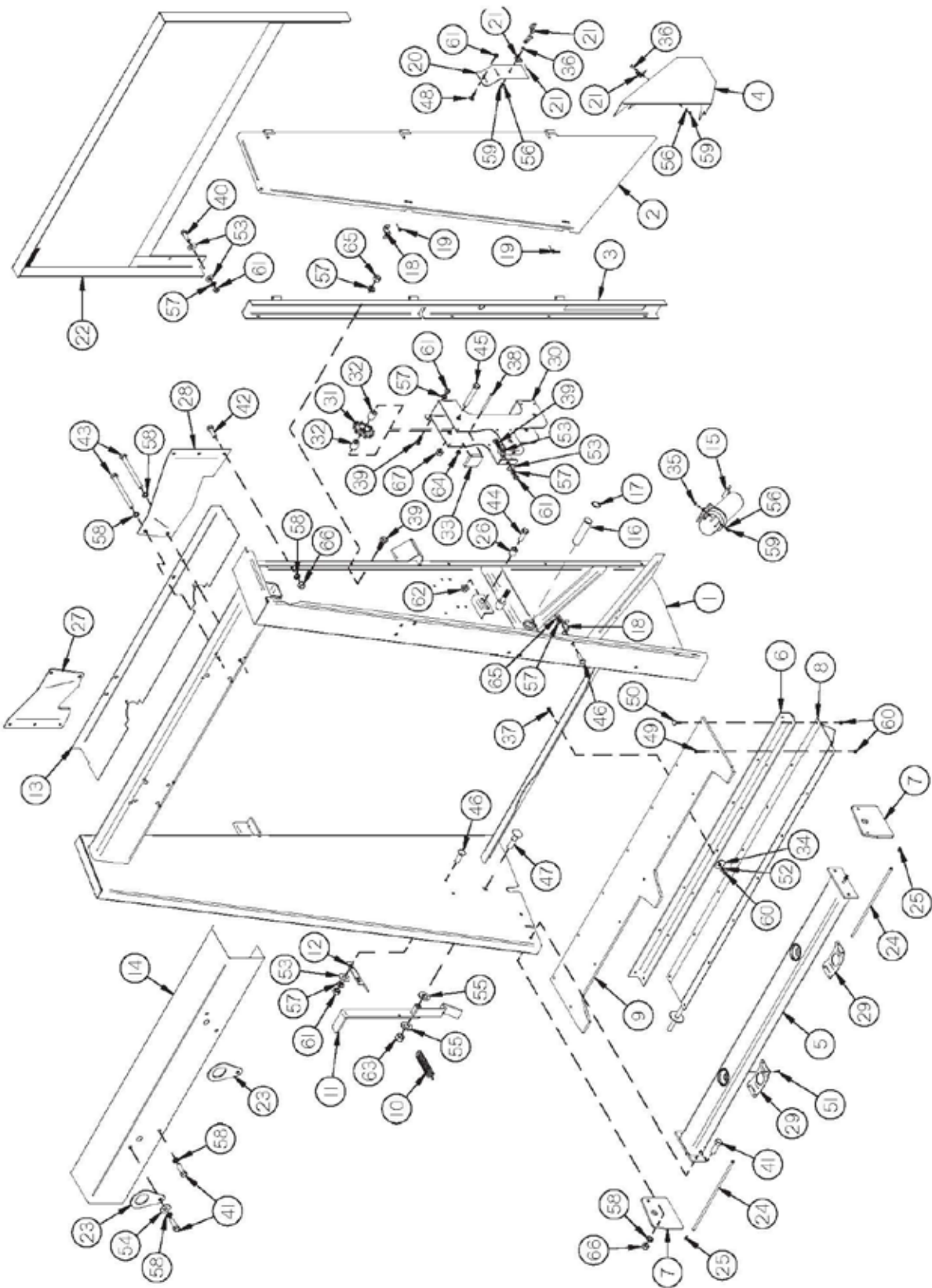

FIGURE 11

VERTICAL BEATERS FRAME ASSEMBLY

<u>ITEM</u>	<u>QTY</u>	<u>PART#</u>	<u>DESCRIPTION</u>
1	1	HGV55	FRAME
2	1	77528	REAR SHIELD
3	1	77529	SHIELD FILLER
4	1	HGV7	CROSS SHAFT SHIELD
5	1	HGV8	BEATER BOTTOM MOUNT
6	1	HGV9	PAN HINGE
7	2	HGV10	LEG
8	1	HGV11	PAN BOTTOM
9	1	HGV12	PAN
10	1	K103	SPRING
11	1	HGV13	PAN HANDLE
12	1	HGV14	PAN HANDLE STOP
13	1	HGV56	GEARBOX BOTTOM SHIELD SUPERIOR
14	1	HGV57	GEARBOX TOP SHIELD SUPERIOR
15	1	S522	MANUAL HOLDER
16	1	HGV18	SPROCKET IDLER SHAFT
17	1	12V62	SNAP RING
18	2	F69	SHIELD BRACKET
19	2	GM572	CLIP PIN W/LANYARD
20	1	42N105	BACK STAKE FILLER
21	1	X233	COMPLETE LATCH
22	1	79411	STONE GUARD
23	2	HGV50	LIFTING EYE
24	2	HGV51	GREASE LINE
25	2	56694	GREASE FITTING
26	1	16SV44	TIGHTENER SPACER
27	1	HGV107	MAIN PANEL BRACE LH
28	1	HGV106	MAIN PANEL BRACE RH
29	2	26VB56	HUB CAP RETAINER
30	1	HGV131	IDLER BRACKET
31	3	16SV328	SPROCKET W/BEARING (80-C-12)
32	6	HGV111	SPROCKET SPACER
33	3	HGV109	CHAIN POLY BLOCK
34	7	YWCU12005	WASHER, CUSTOM, FLAT, .435 ID X 1-7/8 OD
35	3	YBHH08100	BOLT HEX, 1/4 X 3/4 G5
36	2	YBHH08010	BOLT HEX, 1/4 X 1 G5
37	7	YBHH10010	BOLT HEX, 5/16 X 1 G5
38	6	YBHH10125	BOLT HEX, 5/16 X 4-1/2 G5
39	9	YBHH12010	BOLT HEX, 3/8 X 1 G5
40	4	YBHH12035	BOLT HEX, 3/8 X 1-1/4 G5
41	8	YBHH16030	BOLT HEX, 1/2 X 1-1/2 G5
42	6	YBHH16047	BOLT HEX, 1/2 X 1-1/4 G5
43	8	YBHH16160	BOLT HEX, 1/2 X 5-1/2 G5
44	1	YBHH24035	BOLT HEX, 3/4 X 2-1/4 G5
45	3	YBHH24080	BOLT HEX, 3/4 X 5 G5

FIGURE 11 **VERTICAL BEATERS FRAME ASSEMBLY**

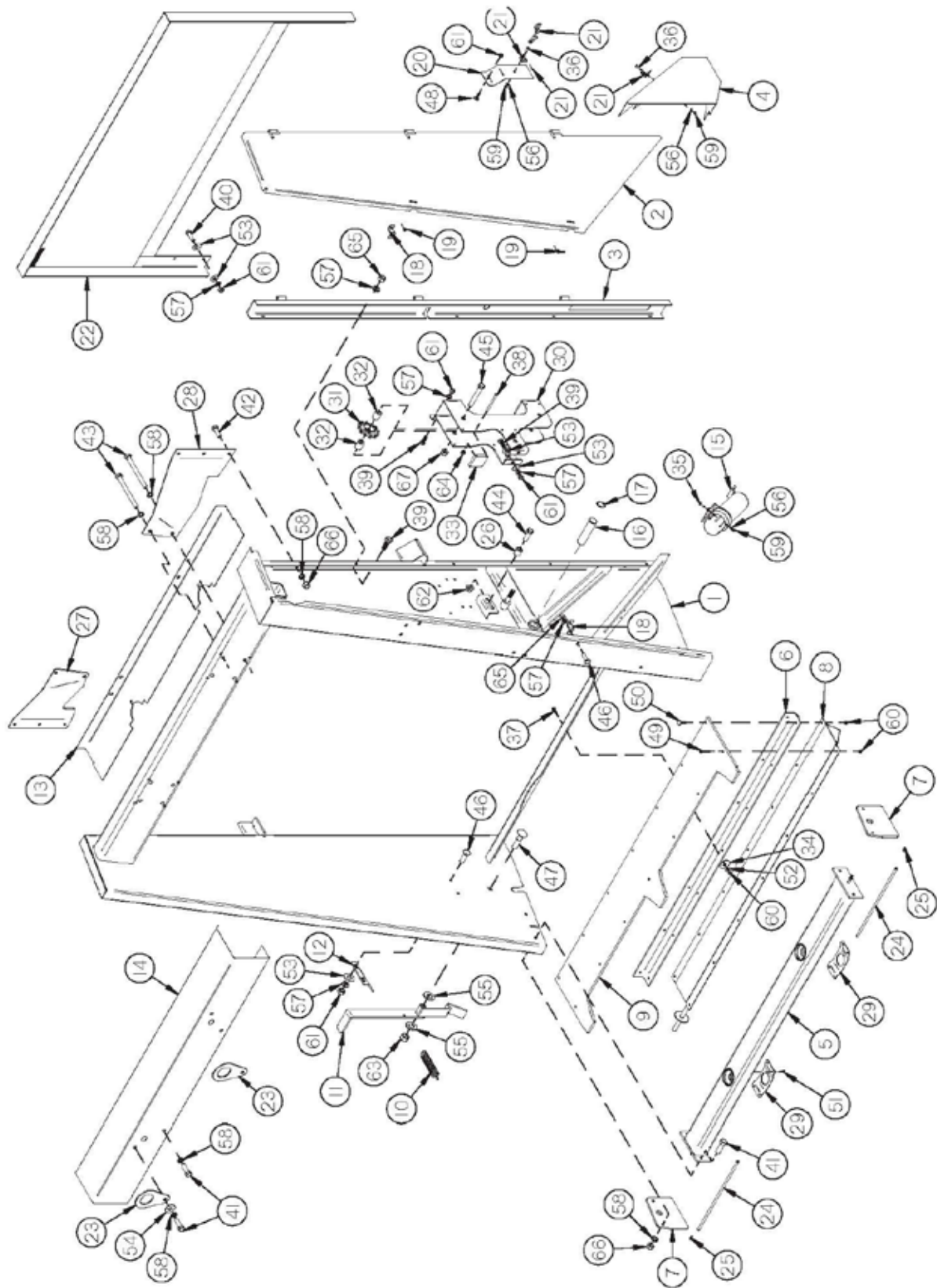

FIGURE 11

VERTICAL BEATERS FRAME ASSEMBLY

<u>ITEM</u>	<u>QTY</u>	<u>PART#</u>	<u>DESCRIPTION</u>
46	4	YBCR12010	BOLT CARRIAGE, 3/8 X 1 G5
47	1	HGV108	LATCH PIVOT BOLT
48	1	YBPL12010	BOLT FLAT HEAD, PLOW, 3/8 X 1-1/4 G5
49	7	YSFS10005	SCREW FLAT HEAD, SOCKET CAP, 5/16 X 1
50	7	YBSB10005	BOLT STEP, 5/16 X 1-1/2
51	8	YSDR08005	SCREW SELF DRILLING, 1/4 X 1
52	7	YWFL10005	WASHER FLAT, 5/16
53	14	YWFL12005	WASHER FLAT, 3/8
54	2	YWFL16005	WASHER FLAT, 1/2
55	2	16SV49	SHIM, .074
56	5	YWLO08005	WASHER LOCK, 1/4
57	17	YWLO12005	WASHER LOCK, 3/8
58	22	YWLO16005	WASHER LOCK, 1/2
59	5	YNHX08005	NUT HEX, 1/4
60	21	YNHX10005	NUT HEX, 5/16
61	11	YNHX12005	NUT HEX, 3/8
62	1	YNFG24006	NUT HEX, FLANGED - LOCK, 3/4
63	1	YNRL24005	NUT HEX, REVERSIBLE SIDE LOCK, 3/4
64	6	YNL10005	NUT HEX, TOP LOCK, 5/16
65	7	YNL12005	NUT HEX, TOP LOCK, 3/8
66	10	YNL16005	NUT HEX, TOP LOCK, 1/2
67	3	YNL24005	NUT HEX, TOP LOCK, 3/4

FIGURE 12
VERTICAL BEATERS DRIVE TRAIN



FIGURE 12

VERTICAL BEATERS DRIVE TRAIN

<u>ITEM</u>	<u>QTY</u>	<u>PART#</u>	<u>DESCRIPTION</u>
1	1	HGV119	LH BEATER
2	1	HGV121	RH BEATER
3	28	HGV122	LH BEATER BLADE
4	28	HGV123	RH BEATER BLADE
5	2	HGV27	SEAL
6	2	B5	BEARING CONE
7	2	B5A	BEARING CUP
8	2	3G18	BEARING CUP
9	2	3G7	BEARING CONE
10	2	17G144	HUB CAP
11	2	56N174	SQUARE KEY W/ ROUND ENDS, 3/8 X 2 (HARD)
12	1	HGV58	LH COMPLETE GEARBOX
13	2	26VB37	BEATER HEX PLUG
14	6	42N25	SPROCKET, (50-B-20)
15	3	HGV124	CONNECTOR CHAIN, (#50) (20P)
*	3	D118	CONNECTOR LINK (#50)
16	1	HGV59	GEARBOX CROSS SHAFT
17	1	HGV60	RH COMPLETE GEARBOX
18	1	HGV61	GEARBOX DRIVE SHAFT
19	1	HGV41	BEARING
20	1	HGV25	SPROCKET, (80-B-20)
21	1	HGV125	CHAIN (#80) (137P)
*	1	F157	CONNECTOR LINK (#80)
A/R	A/R	HGV163	HALF CHAIN LINK (#80)
22	2	12V52	BEARING
23	2	12V77	TIGHTENER SPROCKET
24	1	HGV36	BEATER TIGHTENER
25	2	42N100	BEARING
26	1	HGV37	SPROCKET, (80-A-36 & 80-A-20) 1000 RPM
27	1	HGV127	DRIVE CHAIN, (#80H), (117P) 1000 RPM
*	1	F157	CONNECTOR LINK, (#80H)
28	1	10R14	SPRING
29	1	HGV30	SPACER
30	2	HGV43	PRIMARY TIGHTENER SPACER
31	1	HGV42	TIGHTENER
32	2	56N160	SPRING HOLDER
33	1	ST36	SPRING
34	8	26VB57	FAN BLADE
35	2	HGV129	BEATER RUBBER SEAL
36	2	HGV130	BEATER SEAL CAP
37	2	HGV102	BEATER STUB SHAFT
38	7	PB136	SQUARE KEY W/ ROUND ENDS, 3/8 X 2
39	2	YPCT05020	COTTER PIN, 5/32 X 1-1/2
40	16	YSKP12025	SCREW SET, SOCKET, KNURLED CUP PT, 3/8 X 3/8

***MEANS NOT SHOWN**

A/R MEANS AS REQUIRED

FIGURE 12
VERTICAL BEATERS DRIVE TRAIN



FIGURE 12

VERTICAL BEATERS DRIVE TRAIN

<u>ITEM</u>	<u>QTY</u>	<u>PART#</u>	<u>DESCRIPTION</u>
41	12	YBHH08100	BOLT HEX, 1/4 X 3/4 G5
42	3	YBHH18010	BOLT HEX, 9/16 X 1-3/4 G5
43	1	YBHH18115	BOLT HEX, 9/16 X 2-1/2 G5
44	112	YBHH20020	BOLT HEX, 5/8 X 1-3/4 G5
45	2	YBHH24050	BOLT HEX, 3/4 X 3 G5
46	16	YBCR16010	BOLT CARRIAGE, 1/2 X 1-1/2 G5
47	2	YBTE12045	BOLT TURNED EYE, 3/8 X 5
48	2	YWFL12005	WASHER FLAT, 3/8
49	1	YWFL24005	WASHER FLAT, 3/4
50	2	YWFL24010	WASHER FLAT, 3/4
51	12	YWLO08005	WASHER LOCK, 1/4
52	2	YWLO12005	WASHER LOCK, 3/8
53	16	YWLO16005	WASHER LOCK, 1/2
54	5	YWLO18005	WASHER LOCK, 9/16
55	112	YWLO20005	WASHER LOCK, 5/8
56	2	YNHX12005	NUT HEX, 3/8
57	5	YNHX18005	NUT HEX, 9/16
58	2	YNRL24005	NUT HEX, REVERSIBLE - SIDE LOCK, 3/4
59	2	YNL12005	NUT HEX, TOP LOCK, 3/8
60	16	YNL16005	NUT HEX, TOP LOCK, 1/2
61	112	YNL20005	NUT HEX, TOP LOCK, 5/8
62	1	YNL24005	NUT HEX, TOP LOCK, 3/4
63	2	YNSL24010	NUT HEX, SLOTTED, 3/4
64	1	60533	TIGHTER SPACER

FIGURE 13

SUPERIOR GEARBOX LEFT

<u>ITEM</u>	<u>QTY</u>	<u>PART#</u>	<u>DESCRIPTION</u>
1	1	HGV88	BOTTOM HOUSING
2	1	HGV89	TOP HOUSING
3	1	HGV90	OUTPUT SHAFT
4	1	HGV105	INPUT SHAFT
5	2	HGV91	BEARING CONE
6	3	HGV92	BEARING CUP
7	2	HGV93	SEAL
8	1	23N288	NIPPLE, 3/8
9	1	HGV95	PLUG, 1/2 NPT
10	9	YSHS12012	SOCKET HEAD CAP SCREW, 3/8 X 2-1/4
11	1	17G58	VENT CAP
12	1	JB82	BUSHING, 1/2 TO 3/8
13	1	HGV99	CAP
14	1	HGV94	BEARING CONE
15	1	HGV97	BEARING CONE
16	1	HGV112	BEARING CUP
17	1	HGV98	RETAINING PING
*	1	HGV58	LH COMPLETE GEARBOX

***MEANS NOT SHOWN**

FIGURE 14

SUPERIOR GEARBOX RIGHT

<u>ITEM</u>	<u>QTY</u>	<u>PART#</u>	<u>DESCRIPTION</u>
1	1	HGV88	BOTTOM HOUSING
2	1	HGV89	TOP HOUSING
3	1	HGV90	OUTPUT SHAFT
4	1	HGV101	INPUT SHAFT
5	2	HGV91	BEARING CONE
6	3	HGV92	BEARING CUP
7	3	HGV93	SEAL
8	1	23N288	NIPPLE, 3/8
9	1	HGV95	PLUG, 1/2 NPT
10	9	YSHS12012	SCREW SOCKET HEAD, CAP, 3/8 X 2-1/4
11	1	17G58	VENT CAP
12	1	JB82	BUSHING, 1/2 TO 3/8
13	1	HGV94	BEARING CONE
14	1	HGV97	BEARING CONE
15	1	HGV112	BEARING CUP
16	1	HGV98	RETAINING RING
*	1	HGV60	RH COMPLETE GEARBOX

***MEANS NOT SHOWN**

FIGURE 15 CHAIN OILER

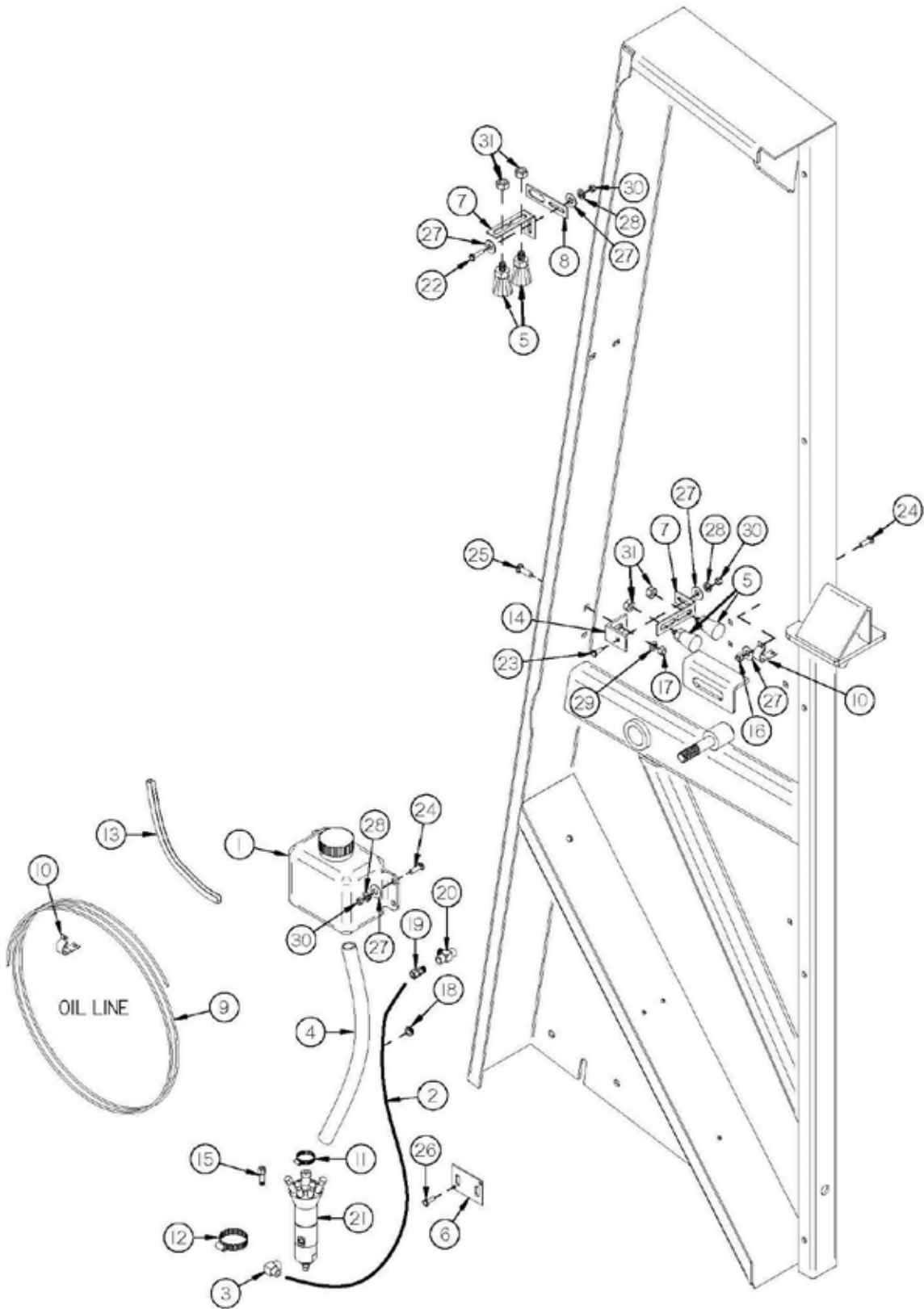

FIGURE 15 CHAIN OILER

<u>ITEM</u>	<u>QTY</u>	<u>PART#</u>	<u>DESCRIPTION</u>
1	1	HGV63	RESERVOIR
2	1	HGV64	HYD HOSE, 1/4 X 80
3	1	HGV65	O-RING/JIC ELBOW
4	4	HGV66	FILLER HOSE
5	4	HGV67	BRUSH
6	1	HGV135	OILER MOUNT
7	2	HGV69	BRUSH BRACKET
8	1	HGV70	BRACKET MOUNT
9	1	HGV71	OILER TUBE, 5/32 OD
10	6	HGV72	SMALL TUBE HOLDER
11	2	HGV75	HOSE CLAMP, 1
12	1	HGV74	HOSE CLAMP, 2
13	1	HGV77	EDGING, (12)
14	1	HGV170	ANGLE
15	4	HGV84	COMPLETE MANIFOLD
16	33	YNTL08005	NUT HEX, TOP LOCK, 1/4
17	1	YNTL12005	NUT HEX, TOP LOCK, 3/8
*	1	HGV62	OILER KIT
18	1	8651	RUBBER GROMMET
19	1	DWM233	UNION ADAPTER, 3/8
20	1	WM146	MALE BRANCH TEE, 3/8
21	1	HGV82	PUMP (COMPLETE)
*	1	HGV83	REPAIR KIT
22	11	YBHH08010	BOLT HEX, 1/4 X 1 G5
23	1	YBHH08100	BOLT HEX, 1/4 X 3/4 G5
24	7	YBCR08040	BOLT CARRIAGE, 1/4 X 3/4 G5
25	1	YBCR12010	BOLT CARRIAGE, 3/8 X 1 G5
26	2	YSDR08015	SCREW HEX WASHER HEAD, SLOT THRD ROLL, 1/4 X 1/2
27	11	YWFL08005	WASHER FLAT, 1/4 USS
28	6	YWLO08005	WASHER LOCK, 1/4
29	1	YWLO12005	WASHER LOCK, 3/8
30	6	YNHX08005	NUT HEX, 1/4
31	1	YNHX16005	NUT HEX, 1/2

***MEANS NOT SHOWN**

FIGURE 16 LIGHTING

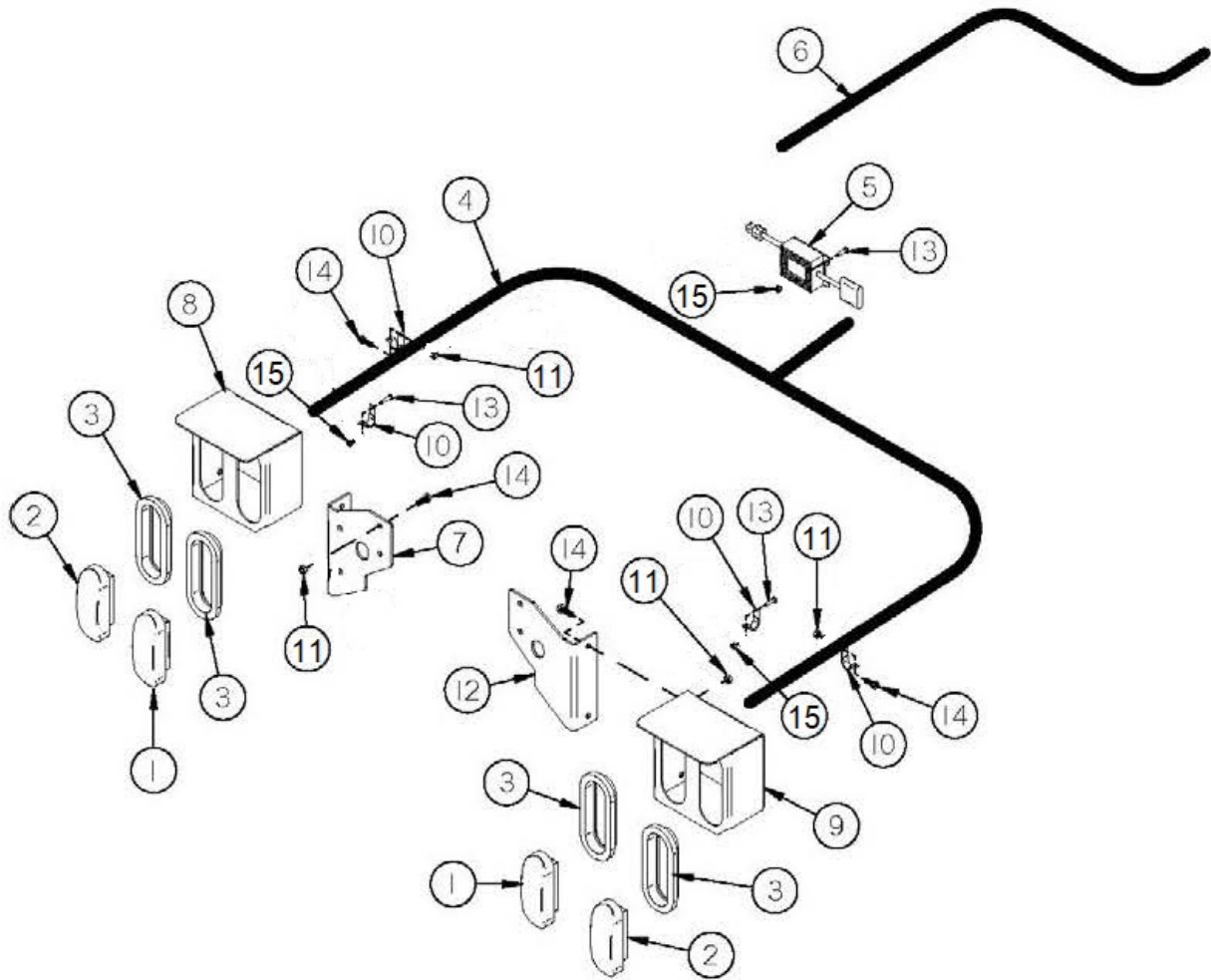

FIGURE 16 LIGHTING

<u>ITEM</u>	<u>QTY</u>	<u>PART#</u>	<u>DESCRIPTION</u>
1	2	S310	RED TAIL LIGHT
2	2	S309	AMBER TAIL LIGHT
3	4	S308	RUBBER LIGHT MOUNT
4	1	56N155	HARNESS, TAIL LIGHT
5	1	69908	CONTROL BLINKER MODULE
6	1	1140	WIRE HARNESS
7	1	HGV137	LIGHT BRACKET MOUNT LH
8	1	55N61	LIGHT BRACKET LH
9	1	55N62	LIGHT BRACKET RH
10	14	HGV162	RUBBER WIRE HOLDER, 1/2
11	10	YNFG12006	NUT FLANGE, 3/8 GF
12	1	HGV136	RH LIGHT BRACKET MOUNT
13	5	YBFB08075	BOLT FLANGE, 1/4 X 3/4 G5
14	10	YBFB12003	BOLT FLANGE, 3/8 X 1 G5 ZC
15	5	YNFG08010	NUT FLANGE , 1/4 GF

FIGURE 17
OPTIONAL REAR PAN

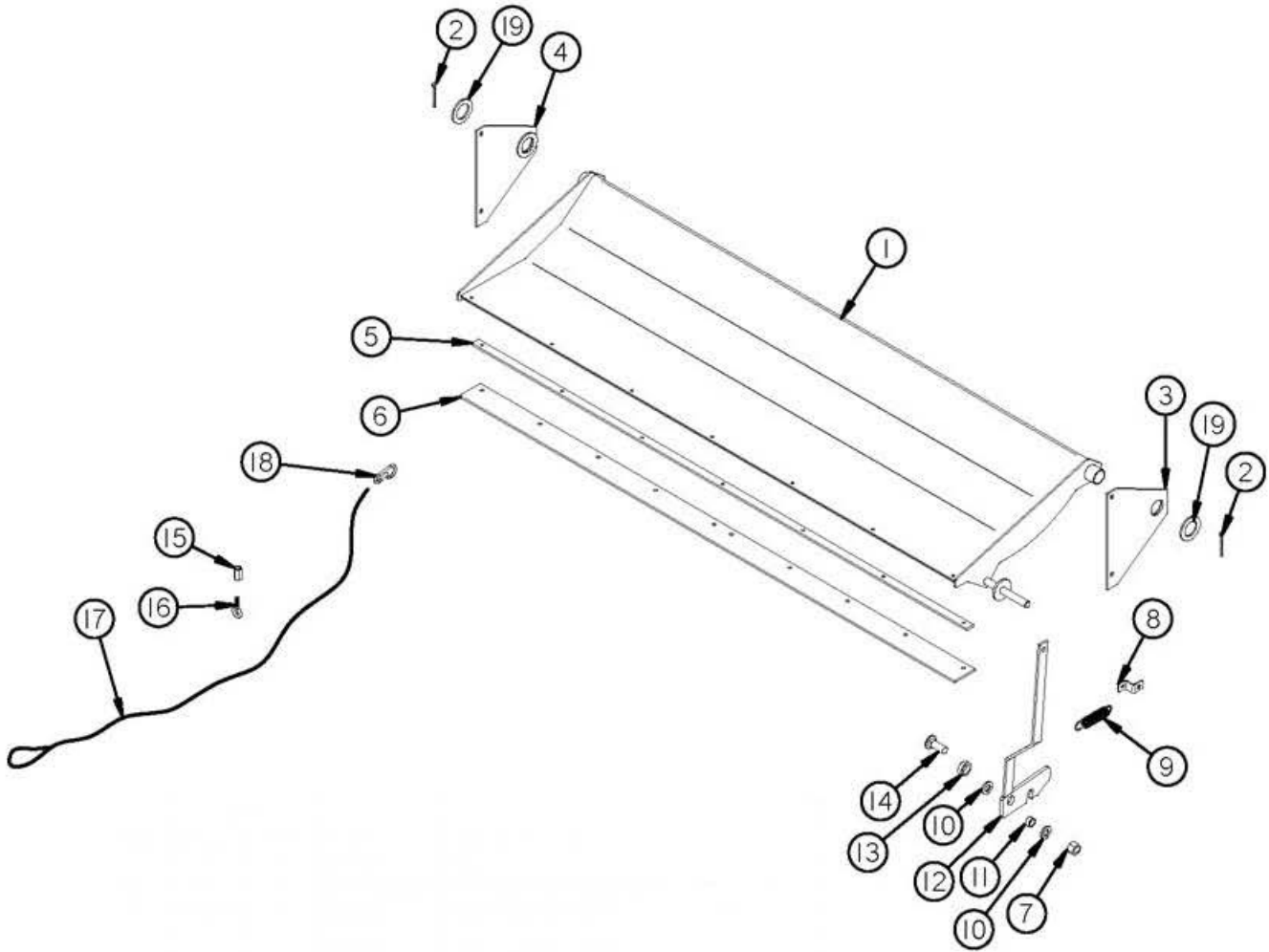

FIGURE 17
OPTIONAL REAR PAN

<u>ITEM</u>	<u>QTY</u>	<u>PART#</u>	<u>DESCRIPTION</u>
1	1	42N127	PAN
2	2	YPCT06020	COTTER PIN, 3/16 X 2
3	1	42N128	PAN PLATE LH
4	1	42N129	PAN PLATE RH
5	1	42N130	PAN STRAP
6	1	42N131	RUBBER
7	1	YNL24005	NUT HEX, TOP LOCK, 3/4
8	1	F69	BRACKET
9	1	ST36	SPRING
10	2	T73	WASHER
11	1	42N132	LATCH BUSHING
12	1	42N133	LATCH
13	1	42N134	LATCH SPACER
14	1	YBCR24003	BOLT CARRIAGE, 3/4 X 2-1/2
15	1	YNCO12005	NUT HEX, COUPLING, 3/8 X 1-1/8
16	1	YBTE12005	BOLT TURNED EYE, 3/8 X 1
17	1	42N136	BLADE HOLDER RH
18	1	YMSN10005	SNAP HOOK, 5/16
19	2	56N170	PAN WASHER

FIGURE 18
1-3/4 1000 RPM CLUTCHED PTO OPTION

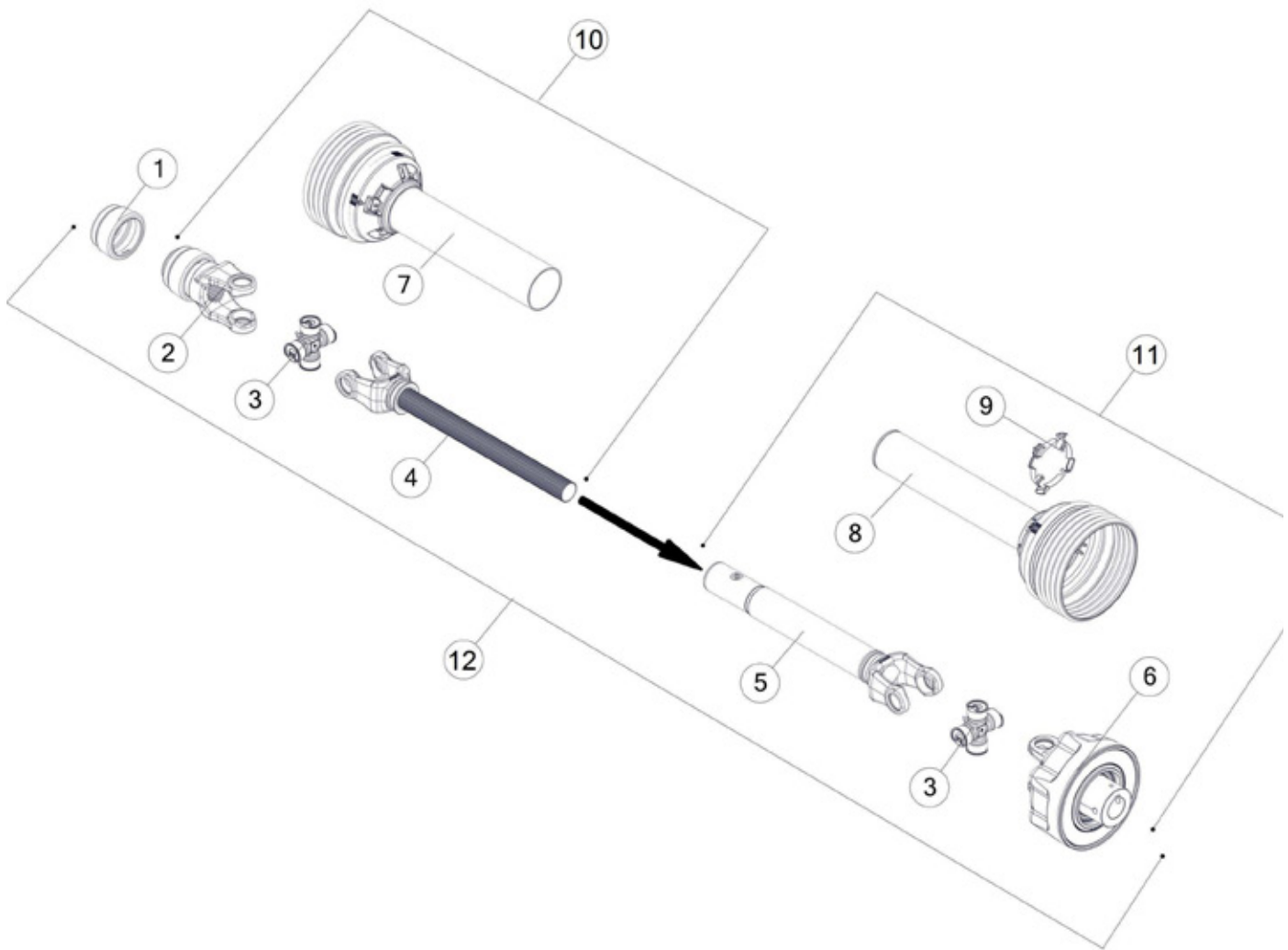

FIGURE 18
1-3/4 1000 RPM CLUTCHED PTO OPTION

<u>ITEM</u>	<u>QTY</u>	<u>PART#</u>	<u>DESCRIPTION</u>
1	1	16SV275	AUTO LOCK REPAIR KIT
2	1	55N69	AUTO LOCK YOKE
3	2	16SV179	CROSS KIT, 35R
4	1	61375	YOKE AND SHAFT
5	1	61378	YOKE AND TUBE
6	1	74196	PTO CLUTCH
7	1	16SV383	OUTER GUARD
8	1	61376	INNER GUARD
9	1	61377	GUARD REPAIR KIT
10	1	74398	TRACTOR HALF PTO W/GUARD
11	1	74401	MACHINE HALF PTO W/GUARD
12	1	74390	COMPLETE PTO
*	1	S402	ADMA SAFETY MANUAL

***MEANS NOT SHOWN**

FIGURE 19
1-3/8 1000 RPM CLUTCHED PTO OPTION

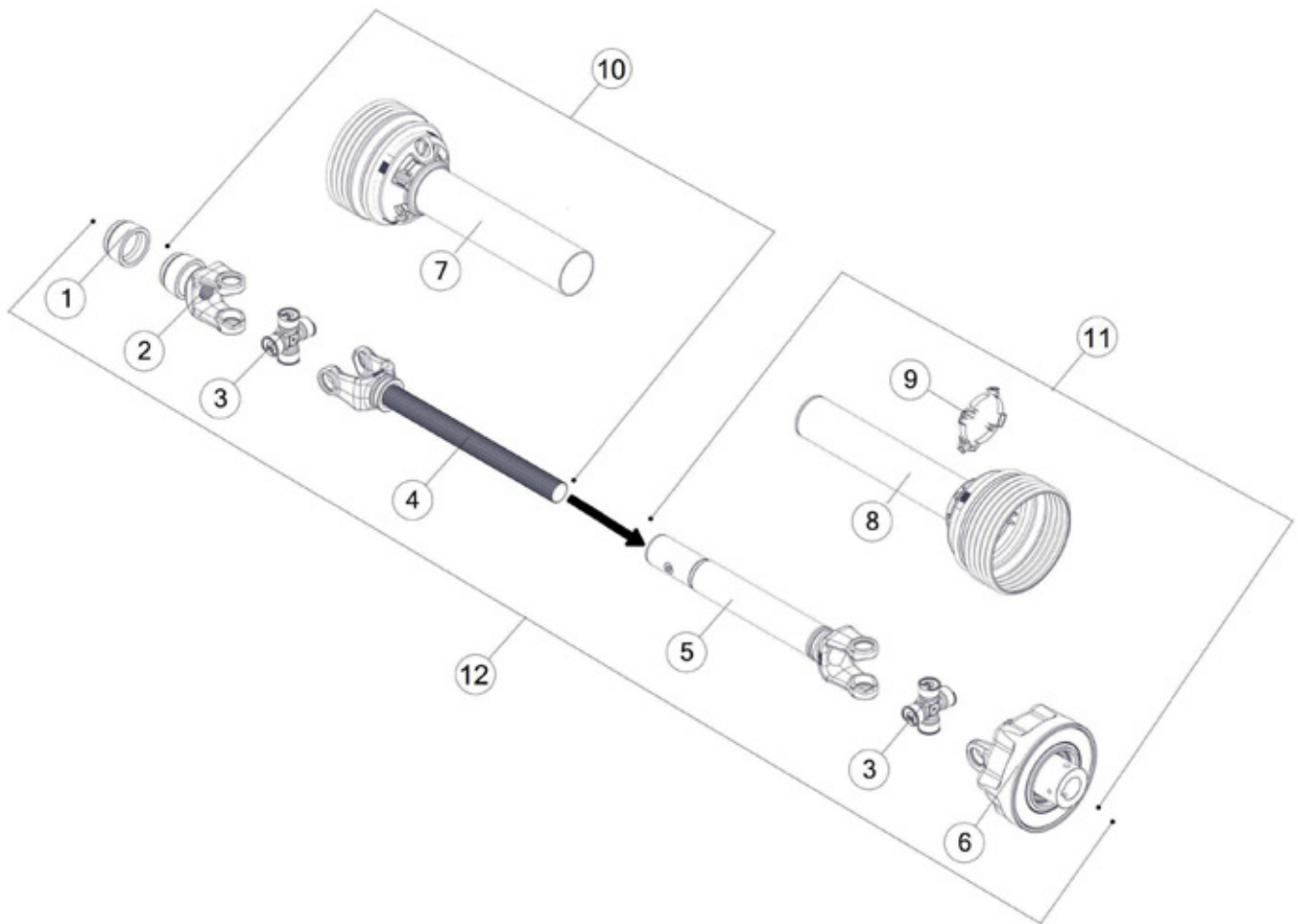

FIGURE 19
1-3/8 1000 RPM CLUTCHED PTO OPTION

<u>ITEM</u>	<u>QTY</u>	<u>PART#</u>	<u>DESCRIPTION</u>
1	1	16SV274	AUTO LOCK REPAIR KIT
2	1	55N68	AUTO LOCK YOKE
3	2	16SV179	CROSS KIT, 35R
4	1	61375	YOKE AND SHAFT
5	1	61378	YOKE AND TUBE
6	1	74196	PTO CLUTCH
7	1	16SV383	OUTER GUARD
8	1	61376	INNER GUARD
9	1	61377	GUARD REPAIR KIT
10	1	74400	TRACTOR HALF PTO W/ GUARD
11	1	74401	MACHINE HALF PTO W/GUARD
12	1	60422	COMPLETE PTO
*	1	S402	ADMA SAFETY MANUAL

***MEANS NOT SHOWN**

FIGURE 20
1-3/8 1000 RPM SHEAR BOLT PTO OPTION

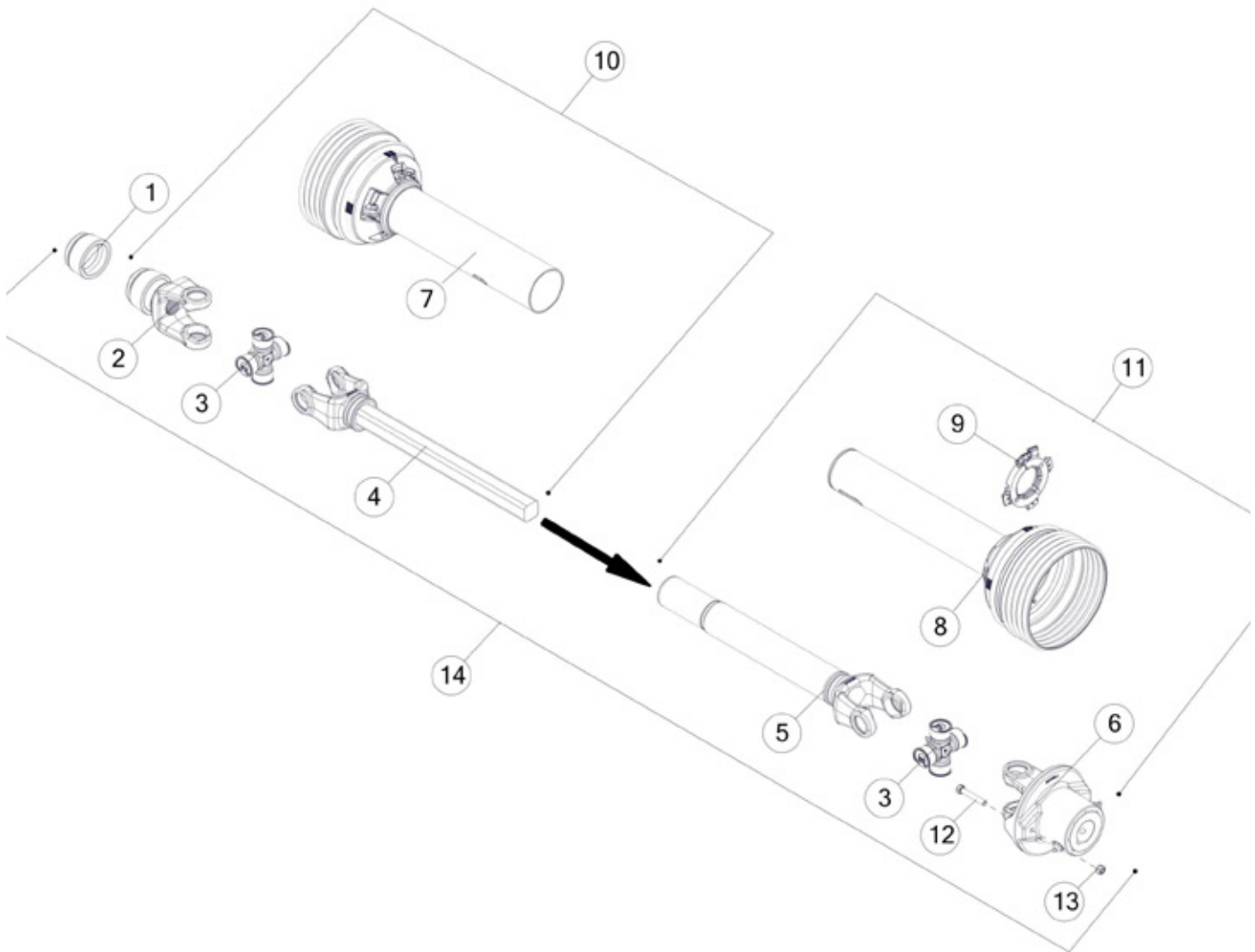

FIGURE 20
1-3/8 1000 RPM SHEAR BOLT PTO OPTION

<u>ITEM</u>	<u>QTY</u>	<u>PART#</u>	<u>DESCRIPTION</u>
1	1	16SV274	AUTO LOCK REPAIR KIT
2	1	55N68	AUTO LOCK YOKE
3	2	16SV179	CROSS KIT, 35R
4	1	42N116	YOKE AND SHAFT
5	1	42N119	YOKE, TUBE, SLIP SLEEVE
6	1	42N120	PTO SHEAR HUB
7	1	42N117	OUTER GUARD
8	1	42N118	INNER GUARD
9	1	16SV181	NYLON REPAIR
10	1	55N72	TRACTOR HALF PTO W/GUARD
11	1	55N76	MACHINE HALF PTO W/GUARD
12	1	YBHH10070	BOLT HEX, 5/16 X 2 G5
13	1	YNL10005	NUT HEX, TOP LOCK, 5/16
14	1	55N78	COMPLETE PTO
*	1	S402	ADMA SAFETY MANUAL

***MEANS NOT SHOWN**

FIGURE 21
1-3/4 1000 RPM SHEAR BOLT PTO OPTION

<u>ITEM</u>	<u>QTY</u>	<u>PART#</u>	<u>DESCRIPTION</u>
1	1	16SV275	AUTO LOCK REPAIR KIT
2	1	55N69	AUTO LOCK YOKE
3	2	16SV179	CROSS KIT, 35R
4	1	42N116	YOKE AND SHAFT
5	1	42N119	YOKE, TUBE, SLIP SLEEVE
6	1	42N120	PTO SHEAR HUB
7	1	42N117	OUTER GUARD
8	1	42N118	INNER GUARD
9	1	16SV181	NYLON REPAIR
10	1	55N73	TRACTOR HALF PTO W/GUARD
11	1	55N76	MACHINE HALF PTO W/GUARD
12	1	YBHH10070	BOLT HEX, 5/16 X 2 G5
13	1	YNL10005	NUT HEX, TOP LOCK, 5/16
14	1	55N79	COMPLETE PTO
*	1	S402	ADMA SAFETY MANUAL

***MEANS NOT SHOWN**

FIGURE 22
OPTIONAL TANDEM

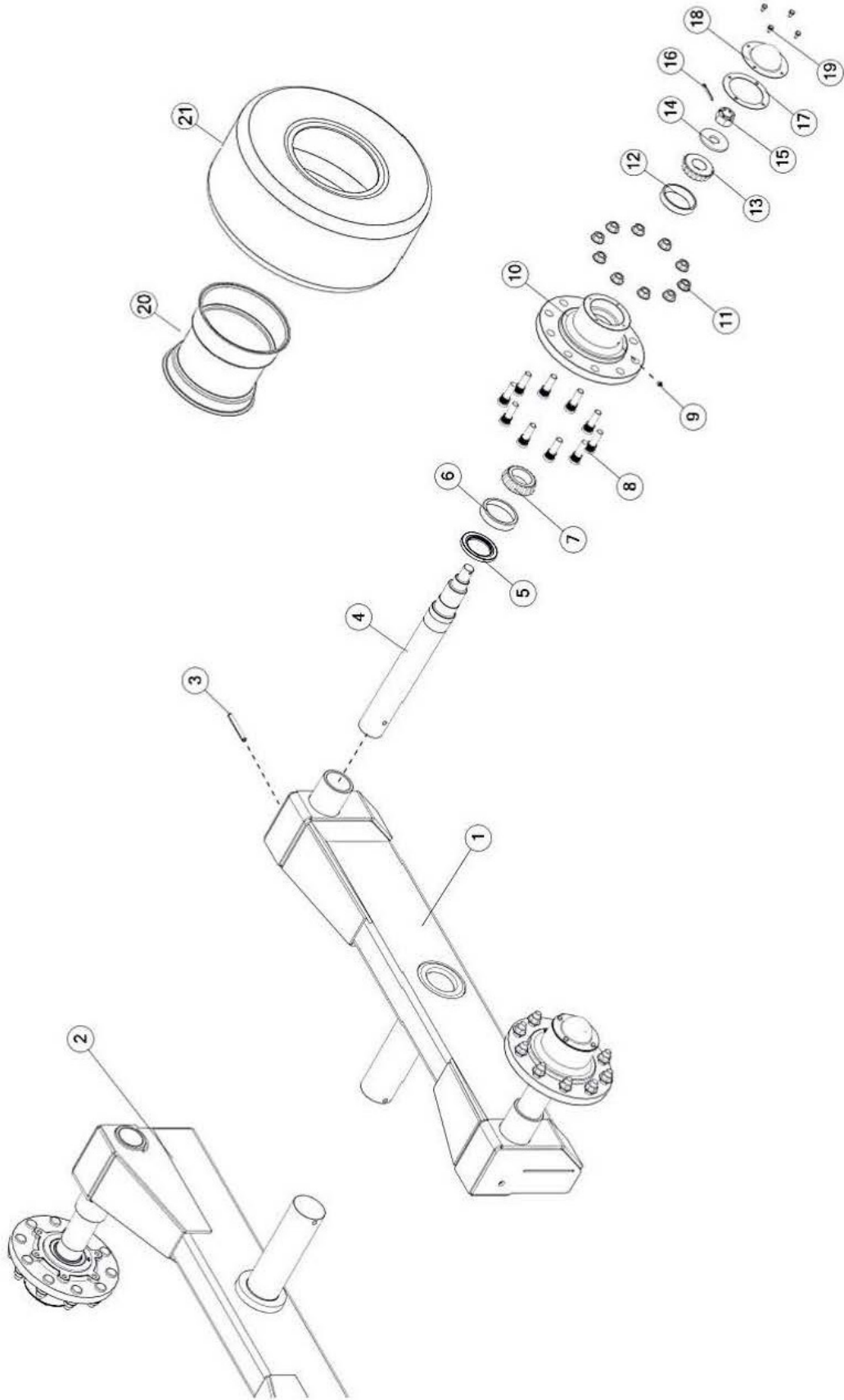

FIGURE 22

OPTIONAL TANDEM

<u>ITEM</u>	<u>QTY</u>	<u>PART#</u>	<u>DESCRIPTION</u>
1	1	59595	TANDEM AXLE LH
2	1	59596	TANDEM AXLE RH
3	4	YPEX16020	EXPANSION PIN, 1/2 X 4
4	4	FBC31	TANDEM SPINDLE
5	4	60N5	SEAL
6	4	60N6	INNER RACE
7	4	60N7	INNER BEARING
8	40	YBSD24010	STUD BOLT, 3/4 UNF X 2-3/4 (3/4 SHOULDER)
9	4	BFR28	GREASE ZERK, 1/8" NPT
10	4	60N8	HUB W/RACES (10 BOLT)
11	40	YNWL24005	NUT, WHEEL, FLG, 3/4 NA, G8
12	4	60N10	OUTER RACE
13	4	60N9	OUTER BEARING
14	4	60N2	SPINDLE WASHER
15	4	YNCA36005	NUT HEX, CASTLE, 1-1/4
16	4	YPCT07005	COTTER PIN, 7/32 X 2
17	4	56234	HUB CAP GASKET
18	4	60N11	HUB CAP
19	16	YBHH10020	BOLT HEX, 5/16 X 1/2 G5
20	4	66777	WHEEL 22.5 X 20
21	4	FBC36	600/50 22.5, TIRE ONLY
*	4	59918	TIRE, 600/50R22.5, ON 22.5X20, 10 BOLT

***MEANS NOT SHOWN**

H&S MFG. CO.

products approved

for the

FEMA

SEAL OF QUALITY

