



# **PARTS BOOK**

**TS5220**

**MANURE SPREADER**

Part #73200

Rev. #08

HSMFG072323

Starting Ser. #322TS20016





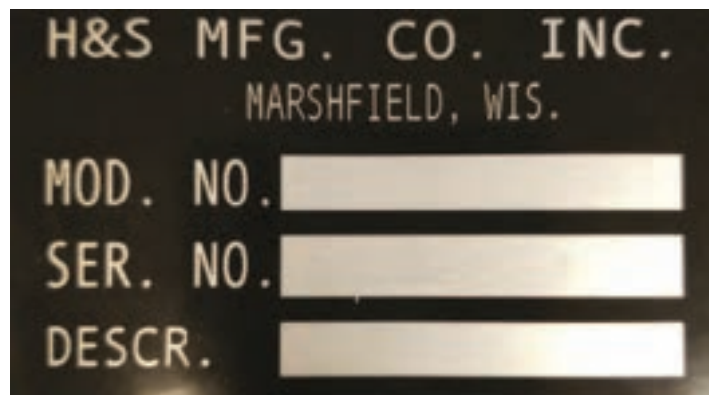
# INSTRUCTIONS FOR ORDERING PARTS

All service parts should be ordered through your authorized H&S dealer. Your Dealership will be able to give you faster service if you will provide them with the following:

1. All references to left or right apply to the machine as viewed from the rear.
2. Parts should not be ordered from illustration only. Please order complete part number.
3. If your dealer has to order parts - give shipping instructions:

VIA truck - large pieces (please specify local truck lines)

VIA United Parcel Service (include full address)



MODEL & SERIAL # CAN BE LOCATED ON THE FRONT MAIN FRAME, BELOW THE PTO

PLEASE RECORD NUMBERS FOR YOUR UNIT FOR QUICK REFERENCE

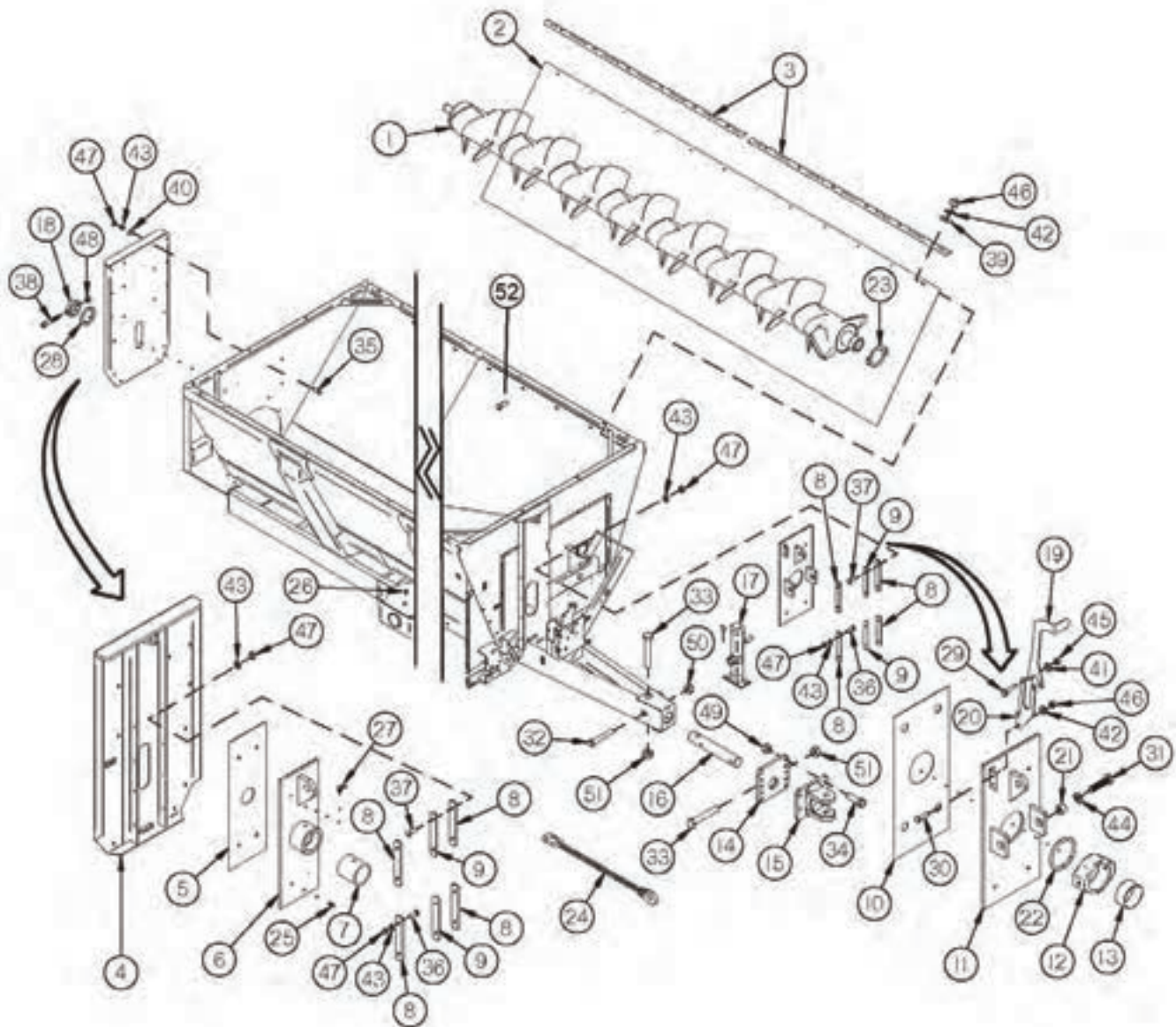
H&S IS CONTINUALLY STRIVING TO IMPROVE ITS PRODUCTS

We must, therefore, reserve the right to make improvements or changes whenever it becomes practical to do so, without incurring any obligation to make changes or additions to the equipment previously sold.





**FIGURE 1**  
**AUGER/LINER/SLIDES/HITCH**





# FIGURE 1

## AUGER/LINER/SLIDES/HITCH

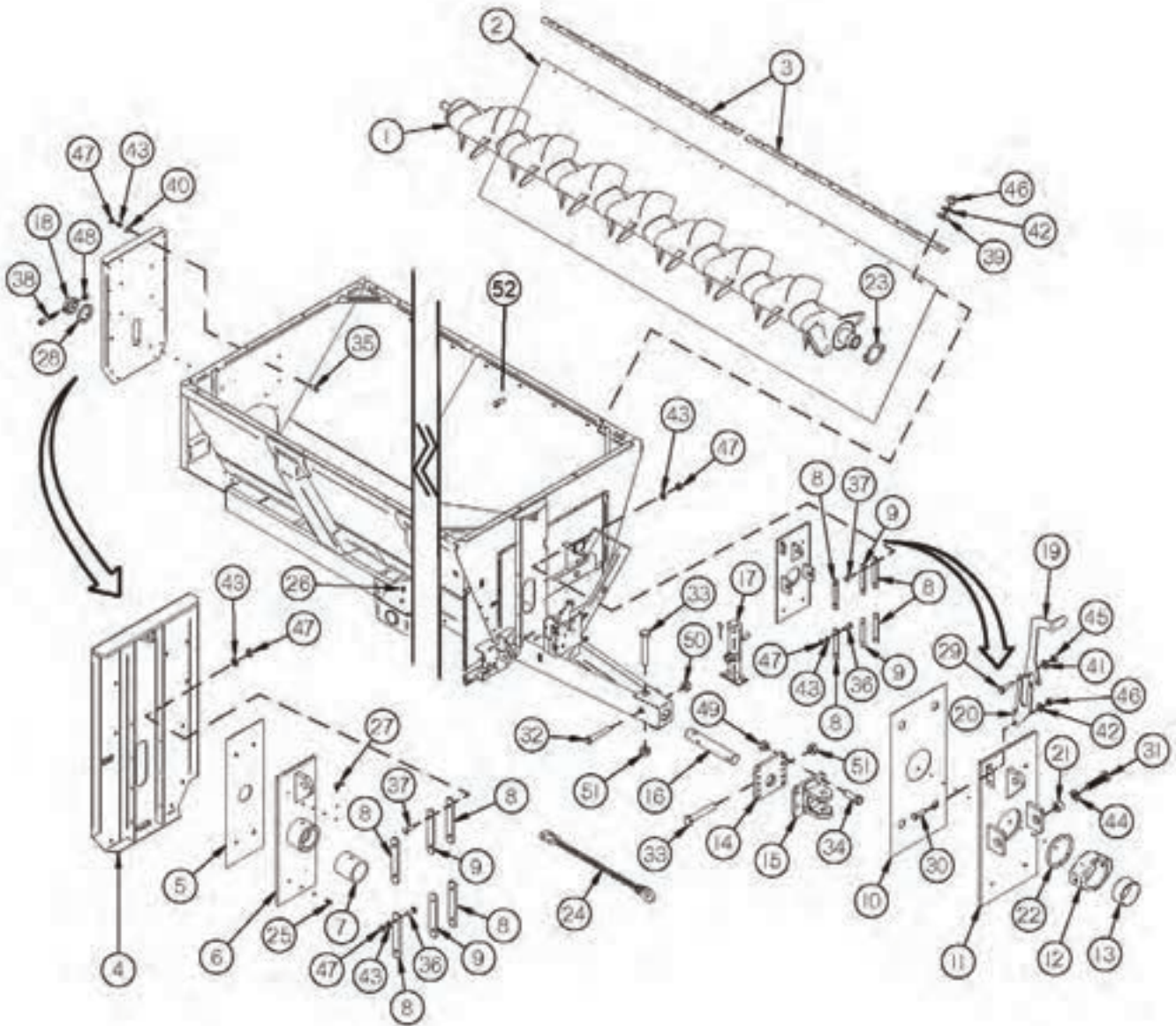
REF #	PART #	DESCRIPTION	QTY
1	TS1	AUGER	1
2	TS2	TUB SIDE POLY	1
3	TS4	POLY TOP HOLD DOWN	1
4	TS6	BACK PANEL	1
5	TS7	BACK SLIDER POLY	1
6	TS8	BACK SLIDER	1
7	TS9	REAR AUGER BUSHING	1
8	TS10	SLIDER GUIDE	8
9	TS308	SLIDER GUIDE THIN	4
10	TS11	FRONT POLY SLIDE	1
11	TS12	FRONT SLIDE PLATE	1
12	TS14	TRUNNION HOUSING	1
13	TS15	FRONT AUGER BEARING	1
*	TS399	TRUNNION HOUSING WITH BEARING	1
14	TS16	ADJUSTABLE SCALE HITCH MOUNT	1
15	TS17	SCALE HITCH ADJUSTABLE CLEVIS	1
16	GM73	HITCH BAR STRAIGHT	1
17	TS306	JACK	1
18	TS19	AUGER BACK COLLAR	1
19	TS207	AUGER INDICATOR TOP	1
20	TS208	AUGER INDICATOR BOTTOM	1
21	TS330	TRUNNION PIVOT BUSHING	2
22	TS33	AUGER SPROCKET RUBBER GASKET	1
23	TS102	TRUNION SPACER	1
24	SC40500	SAFETY CHAIN	1
25	G89	ZERK	4
26	BFR28	ZERK 1/8 NPT	2
27	RG51	ZERK	1
28	TS227	SPACER	A/R
*	TS28	SPACER	A/R
29	YBHH08100	BOLT HEX, 1/4 X 3/4 G5	2
30	YBHH10105	BOLT HEX, 5/16 X 3/4 G5	2
31	YBHH20022	BOLT HEX, 5/8 X 1-3/4 G8	2
32	YBHH24083	BOLT HEX, 3/4 X 5 G8	1
33	YBHH32023	BOLT, 1 X 5 G8	2
34	YBHH24032	BOLT HEX, 3/4 X 2-1/2 G8	4
35	YBCR12010	BOLT CARRIAGE, 3/8 X 1 G5	14
36	YBCR12020	BOLT CARRIAGE, 3/8 X 1-1/4 G5	8
37	YBCR12015	BOLT CARRIAGE, 3/8 X 1-1/2 G5	8







**FIGURE 1**  
**AUGER/LINER/SLIDES/HITCH**





# FIGURE 1

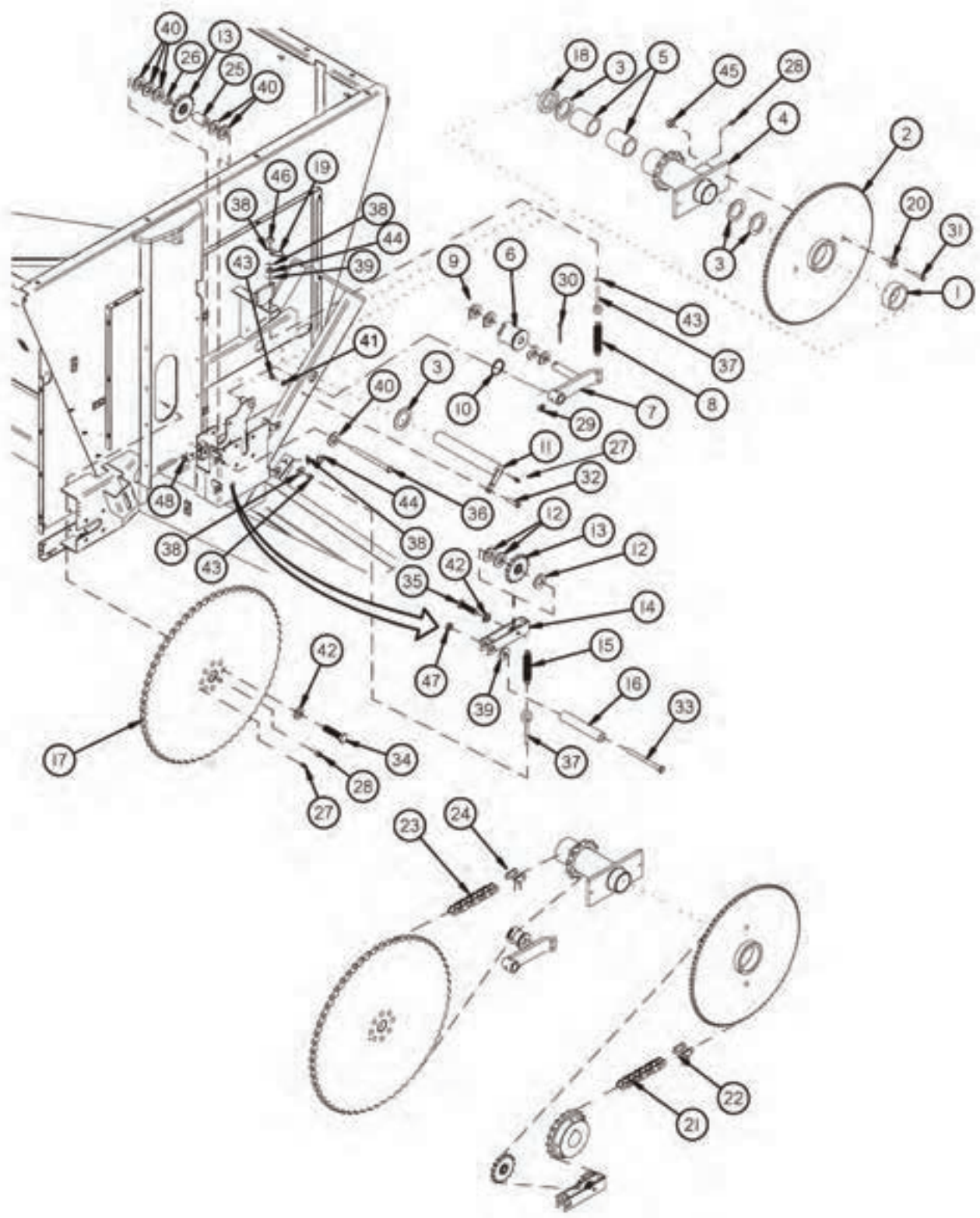
## AUGER/LINER/SLIDES/HITCH

REF #	PART #	DESCRIPTION	QTY
38	YSHS12018	SCREW SOCKET HEAD, 3/8 X 4	1
39	YWFL10005	WASHER FLAT, 5/16 USS	12
40	YWFL12005	WASHER FLAT, 3/8 USS	14
41	YWLO08005	WASHER LOCK, 1/4	2
42	YWLO10005	WASHER LOCK, 5/16	14
43	YWLO12005	WASHER LOCK, 3/8	30
44	YWLO20005	WASHER LOCK, 5/8	2
45	YNHX08005	NUT HEX, 1/4	2
46	YNHX10005	NUT HEX, 5/16	14
47	YNHX12005	NUT HEX, 3/8	30
48	YNL12005	NUT HEX TOP LOCK, 3/8	1
49	YNL24006	NUT HEX TOP LOCK, 3/4 G8	4
50	YNRL24005	NUT HEX REVERSIBLE-SIDE LOCK, 3/4	1
51	YNRL32005	NUT HEX REVERSIBLE-SIDE LOCK, 1	2
52	YBHH10045	BOLT HEX, 5/16 X 1-1/4 G5	12






**FIGURE 2**  
**AUGER DRIVE**







# FIGURE 2

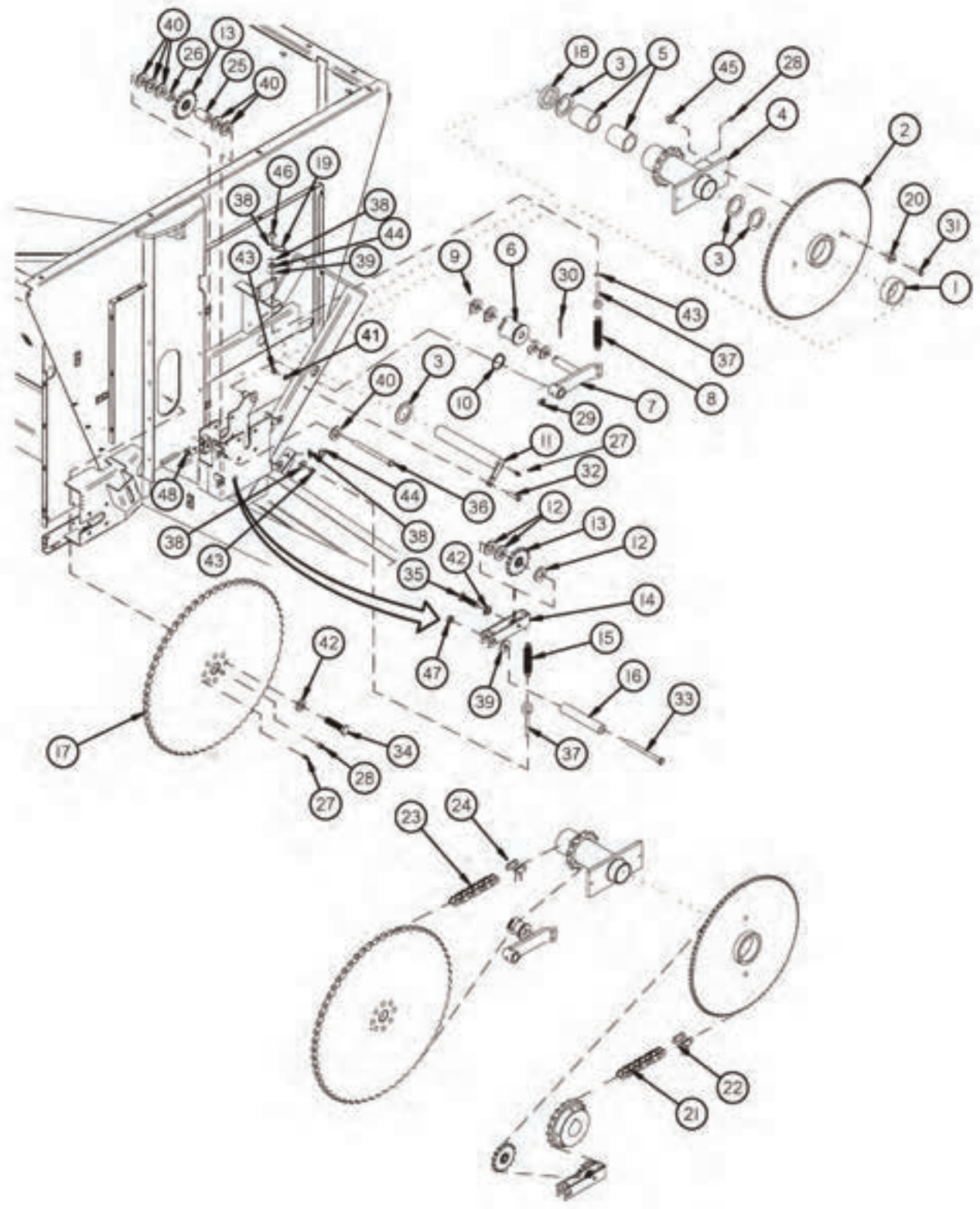
## AUGER DRIVE

REF #	PART #	DESCRIPTION	QTY
1	TS20	BRONZE BUSHING	1
2	TS21	SPROCKET/ASSY 80T STD 540 RPM	1
*	TS312	SPROCKET/ASSY 119T STD 1000 RPM	1
3	TS22	SPACER	A/R
*	56N183	SPACER	A/R
4	TS23	COUNTER SHAFT ASSEMBLY	1
5	73572	BUSHING	2
6	TS25	ROLLER IDLER	1
7	TS26	AUGER CHAIN TENSIONER	1
8	BFR138	SPRING	1
9	YWFL32005	WASHER, FLAT, SAE 1 ZINC	4
10	3G21	SNAP RING	1
11	73569	SHAFT	1
12	T73	SPACER	A/R
*	16SV49	SPACER	A/R
13	TS29	SPROCKET/IDLER ASSY.	2
14	TS30	IDLER ASSY.	1
15	ST36	SPRING EXTENSION	1
*	GM410	SPRING 1000 RPM ONLY	1
16	TS31	TENSIONER PIVOT TUBE	1
17	TS32	SPROCKET ASSY.	1
18	TS328	SPACER	1
19	HGV72	SMALL TUBE HOLDER	1
20	TS34	HARDENED SHEAR BUSHING	2
21	TS39	ROLLER CHAIN #60HE X 138 540-18T&15TSPRCKTS	1
*	TS360	ROLLER CHAIN, #60HE X 136 540 - 13T SPRCKT	1
*	TS361	ROLLER CHAIN, #60HE X 140 540 - 20T SPRCKT	1
*	TS313	ROLLER CHAIN, #60HE X 166 1000 - 15T SPRCKT	1
*	TS362	ROLLER CHAIN, #60HE X 165 1000 - 13T SPRCKT	1
*	TS363	ROLLER CHAIN, #60HE X 167 1000 - 16T SPRCKT	1
22	TS40	LINK/CONNECTOR #60HE	1
23	TS41	ROLLER CHAIN, #100HE X 75	1
24	TS42	LINK/CONNECTOR #100HE	1
25	TS396	IDLER FRONT SPACER	1
26	TS397	IDLER REAR SPACER	1
27	G89	ZERK	2
28	BFR28	ZERK 1/8 NPT	2
29	RG51	ZERK 1/4	1
30	YPCT06005	COTTER PIN, 3/16 X 1-1/2	1





**FIGURE 2**  
**AUGER DRIVE**



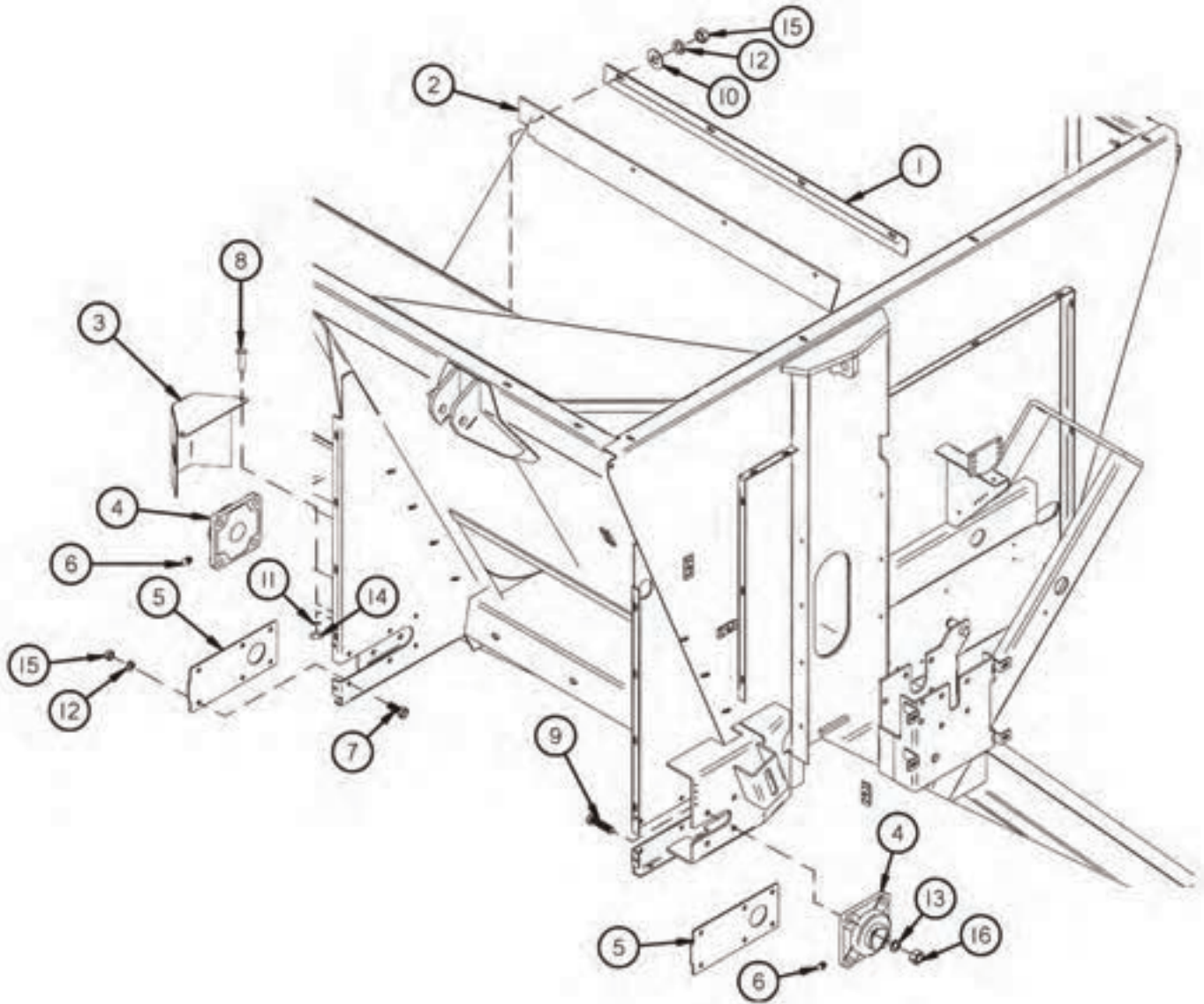


# FIGURE 2

## AUGER DRIVE

REF #	PART #	DESCRIPTION	QTY
31	YBHH10036	BOLT HEX, 5/16 X 1-1/2 G8	6
32	YBHH12090	BOLT HEX, 3/8 X 2-1/2 G5	1
33	YBHH16175	BOLT HEX, 1/2 X 6-1/2 G5	1
34	YBHH20036	BOLT HEX, 5/8 X 2-1/2 G8	8
35	YBHH20025	BOLT HEX, 5/8 X 2 G5	1
36	YBHH20100	BOLT HEX, 5/8 X 6 G5	1
37	YBTE12025	TURNED EYE BOLT, 3/8 X 3	2
38	YWFL12005	WASHER FLAT, 3/8	4
39	YWFL16005	WASHER FLAT, 1/2	2
40	YWFL20005	WASHER FLAT, 5/8	A/R
41	YWLO12005	WASHER LOCK, 3/8	1
42	YWLO20005	WASHER LOCK, 5/8	9
43	YNHX12005	NUT HEX, 3/8	3
44	YNNY12005	NUT HEX NYLON LOCKNUT, 3/8	2
45	YNTL10005	NUT HEX TOP LOCK, 5/16	2
46	YNTL12005	NUT HEX TOP LOCK, 3/8	1
47	YNTJ16005	NUT HEX TOP LOCK, 1/2	1
48	YNTJ20005	NUT HEX TOP LOCK, 5/8	1



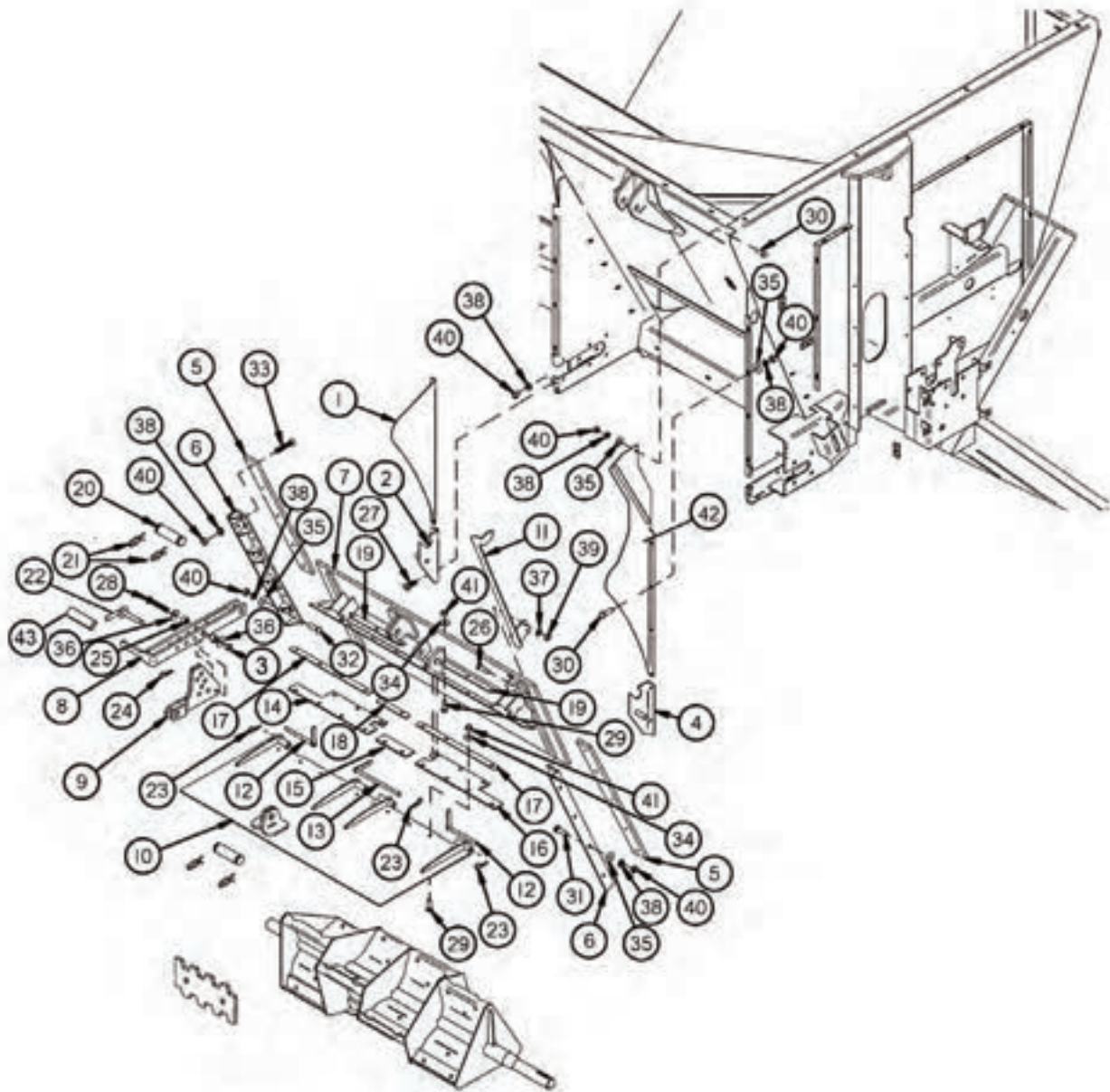








**FIGURE 4**  
**EXPELLER/DISCHARGE GATE/DOOR**





# FIGURE 4

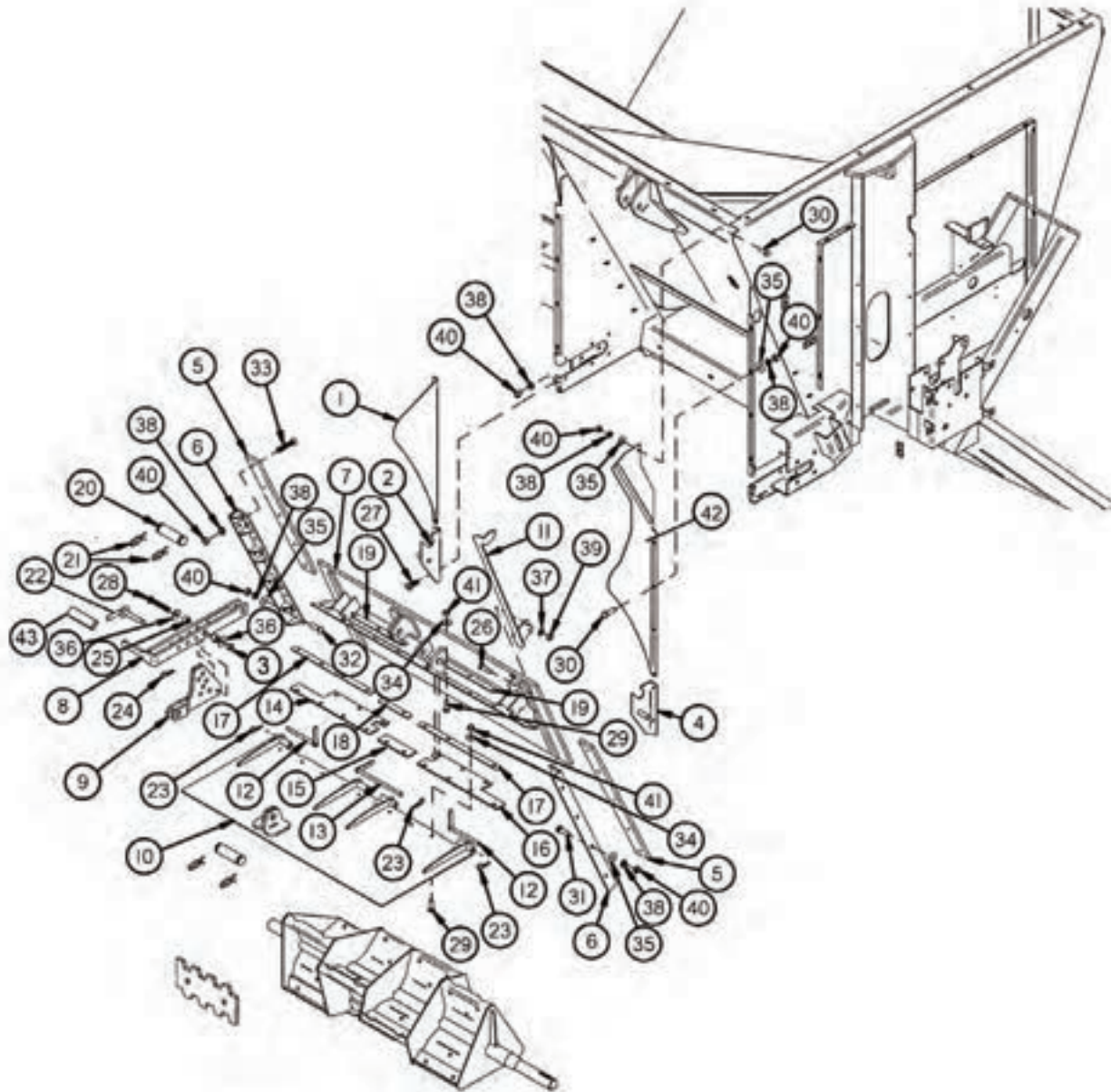
## EXPELLER/DISCHARGE GATE/DOOR

REF #	PART #	DESCRIPTION	QTY
1	TS48	EXPELLER PANEL EXTENSION LH	1
2	TS49	PAN HINGE BRACKET LEFT	1
3	YNTL16005	NUT HEX, TOP LOCK, 1/2	1
*	TS327	EXPELLER SPOUT RH	1
4	TS51	PAN HINGE BRACKET RIGHT	1
5	TS52	DOOR SLIDER POLY	2
6	TS53	EXPELLER DOOR GUIDE	2
7	84592	EXPELLER DOOR	1
8	TS55	DEFLECTOR ADJUSTMENT HANDLE	1
9	84598	DEFLECTOR ADJUSTMENT LINK	1
10	84594	ADJUSTABLE DEFLECTOR	1
11	TS58	DOOR INDICATOR	1
12	TS59	DEFLECTOR SIDE PIN	2
13	TS60	DEFLECTOR MID PIN	1
14	TS61	DEFLECTOR SEAL LH	1
15	TS62	DEFLECTOR SEAL MID	1
16	TS63	DEFLECTOR SEAL RH	1
17	TS64	SEAL STRAP LONG	2
18	TS65	SEAL STRAP MID	1
19	TS66	SEAL STRAP SHORT	2
20	T143	CYLINDER PIN	2
21	T144	CLIP PIN	4
22	TS69	CASTER LOCKING PIN	1
23	YPHR02005	HAIR PIN	3
24	WM378	HAIR PIN W/ LANYARD	1
25	TS307	HANDLE PIVOT	2
26	YBHH10105	BOLT HEX, 5/16 X 3/4 G5	2
27	YBHH12010	BOLT HEX, 3/8 X 1 G5	4
28	YBHH16105	BOLT HEX, 1/2 X 3 G5	1
29	YBCR10010	BOLT CARRIAGE, 5/16 X 1 G5	16
30	YBCR12010	BOLT CARRIAGE, 3/8 X 1 G5	9
31	YBCR12020	BOLT CARRIAGE, 3/8 X 1-1/4 G5	7
32	YBCR12015	BOLT CARRIAGE, 3/8 X 1-1/2 G5	1
33	YSFS12005	SCREW FLAT HEAD SOCKET CAP, 3/8 X 1-1/4	10
34	YWFL10005	WASHER FLAT, 5/16	16
35	YWFL12005	WASHER FLAT, 3/8	17
36	YWFL16005	WASHER FLAT, 1/2	2
37	YWLO10005	WASHER LOCK, 5/16	2
38	YWLO12005	WASHER LOCK, 3/8	31





**FIGURE 4**  
**EXPELLER/DISCHARGE GATE/DOOR**





**FIGURE 4**  
**EXPELLER/DISCHARGE GATE/DOOR**

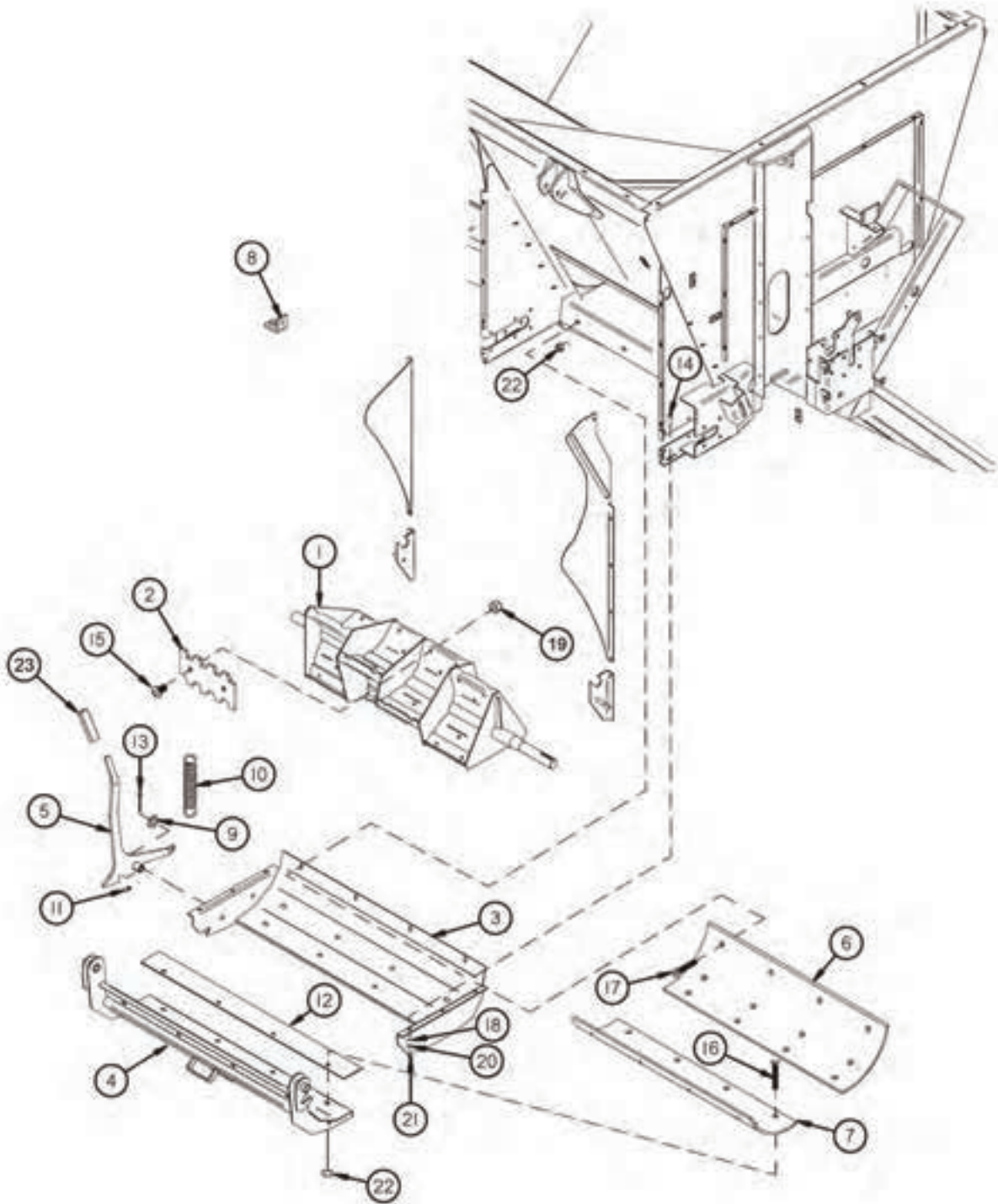
REF #	PART #	DESCRIPTION	QTY
39	YNHX10005	NUT HEX, 5/16	2
40	YNHX12005	NUT HEX, 3/8	31
41	YNL10005	NUT HEX, TOP LOCK, 5/16	16
42	TS50	EXPELLER PANEL EXTENSION, RH	1
43	98251	HANDLE GRIP	1







**FIGURE 5**  
**EXPELLER/DISCHARGE GATE/PAN**







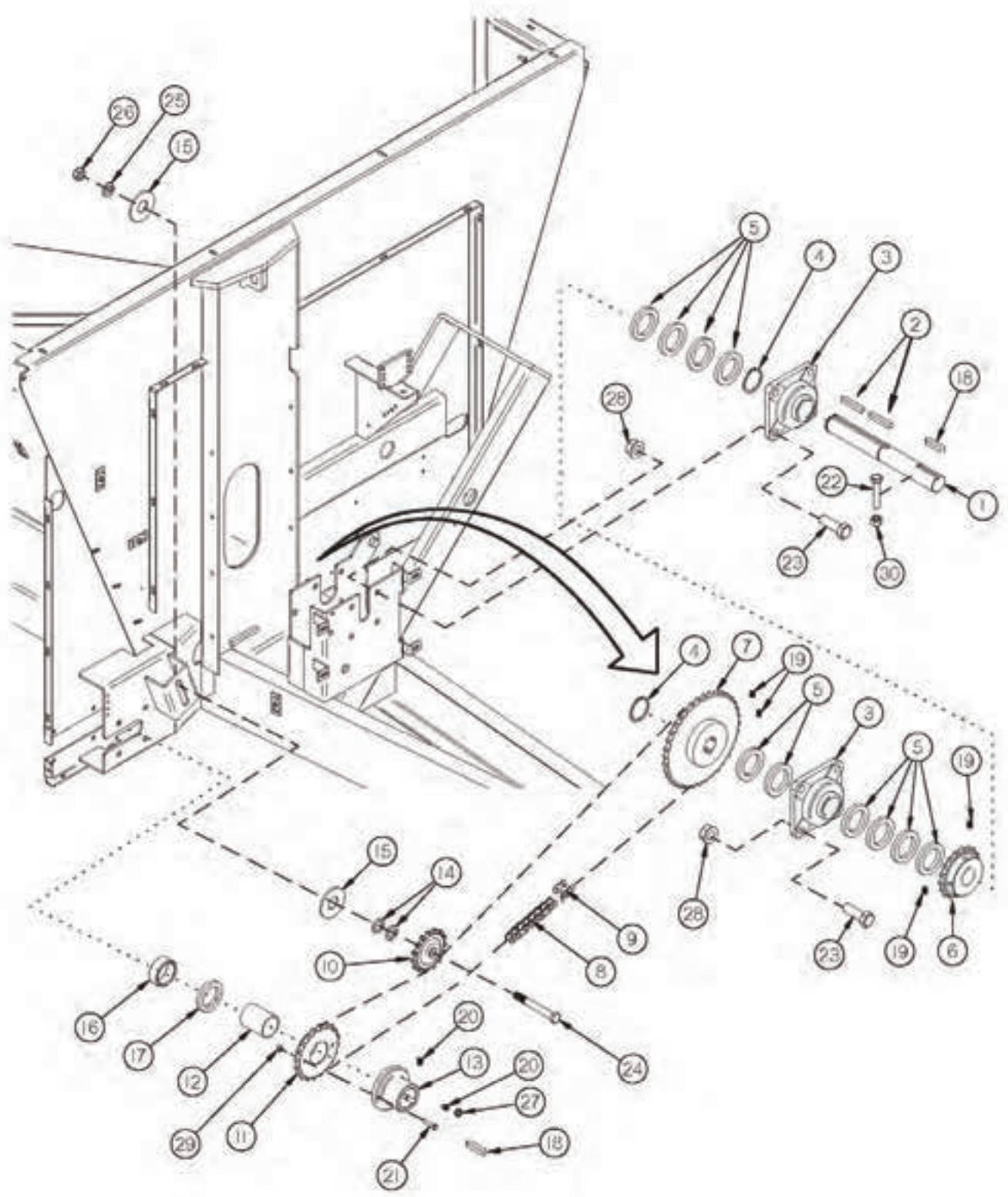
# FIGURE 5 EXPELLER/DISCHARGE GATE/PAN

REF #	PART #	DESCRIPTION	QTY
1	69616	EXPELLER	1
2	TS68	EXPELLER PADDLE	12
3	TS72	SWING AWAY PAN FRAME	1
4	TS73	SWING AWAY PAN	1
5	TS74	PAN LATCH HANDLE	1
6	TS75	EXPELLER BACK POLY	1
7	TS76	EXPELLER PAN POLY	1
8	56N146	SHIELD ANGLE	1
9	T73	SPACER	3
10	K103	SPRING	1
11	G89	GREASE ZERK	1
12	TS18	PAN RUBBER SEAL	1
13	YPCT06010	COTTER PIN, 3/16 X 1-1/4	1
14	YBCR10010	BOLT CARRIAGE, 5/16 X 1 G5	6
15	YBCR16019	BOLT CARRIAGE, 1/2 X 1-3/4 G8	24
16	YSFS16010	BOLT, FLAT SOK, 1/2 X 1-1/2	20
17	YSFS16020	BOLT, FLAT SOK, 1/2 X 1-3/4	4
18	YWFL10005	WASHER FLAT, 5/16	6
19	YNTL16006	NUT HEX, TOP LOCK 1/2 G9	24
20	YWLO10005	WASHER LOCK, 5/16	6
21	YNHX10005	NUT HEX, 5/16	6
22	YNFG16003	NUT FLANGE, 1/2 GF	24
23	98251	HANDLE GRIP	1





**FIGURE 6**  
**INPUT SHAFT/EXPELLER DRIVE**





# FIGURE 6

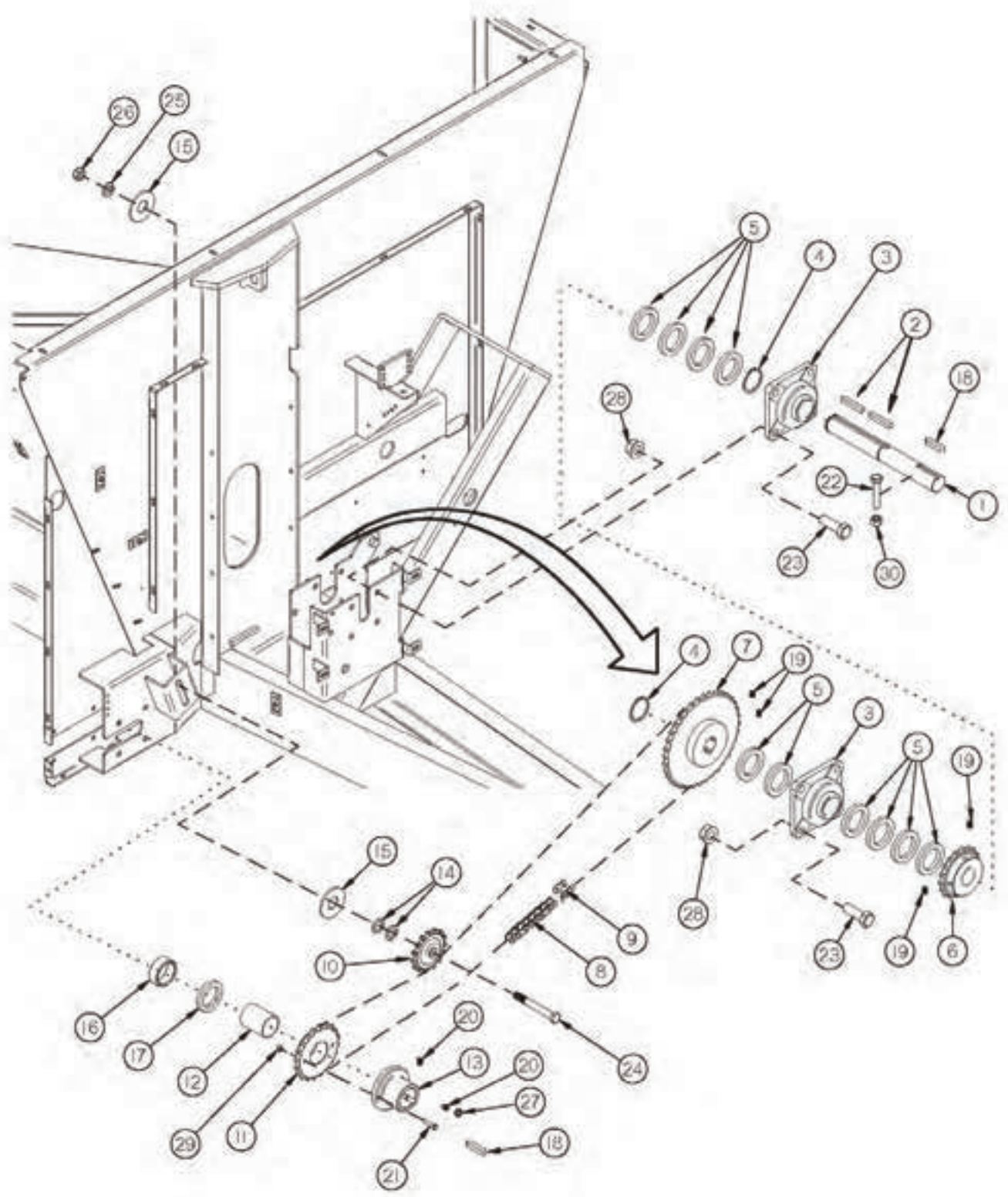
## INPUT SHAFT/EXPELLER DRIVE

REF #	PART #	DESCRIPTION	QTY
1	93258	INPUT SHAFT	1
2	68856	SQUIRE KEY	2
3	12V99	BEARING	2
4	12V62	SNAP RING	2
5	16SV374	SPACER	A/R
*	16SV375	SPACER	A/R
*	16SV439	SPACER	A/R
*	33SV29	SPACER	1
6	TS35	SPROCKET/60B18 STANDARD - 540 RPM	1
*	TS36	SPROCKET/ASSY 13T OP - 540 RPM & 1000 RPM	1
*	TS37	SPROCKET/60B15T OPT - 540 RPM STD - 1000 RPM	1
*	TS38	SPROCKET/60B20 OPT - 540 RPM	1
*	TS364	SPROCKET/60B16 OPT - 1000 RPM	1
7	TS79	SPROCKET/60B36 STD - 540 RPM	1
*	TS80	SPROCKET/EXP DRIVE ASSY 30T OPT - 540 RPM	1
*	TS81	SPROCKET/60X27T OPT - 540 RPM	1
*	TS38	SPROCKET/60B20 OPT - 1000 RPM	1
*	TS318	SPROCKET/ASSY 16T OPT - 1000 RPM	1
*	TS365	SPROCKET/ASSY 15T OPT - 1000 RPM	1
*	TS366	SPROCKET/ASSY 13T OPT - 1000 RPM	1
8	TS82	ROLLER CHAIN, #60HE X 100 540 RPM-36T SPRCKT	1
*	TS367	ROLLER CHAIN, #60HE X 97 540 RPM-30T SPRCKT	1
*	TS368	ROLLER CHAIN, #60HE X 96 540 RPM- 7T SPRCKT	1
*	TS316	ROLLER CHAIN, #60HE X 92 1000 RPM-20T SPRCKT	1
*	TS369	ROLLER CHAIN, #60HE X 90 1000 RPM- 6T SPRCKT	1
*	TS370	ROLLER CHAIN, #60HE X 89 1000 RPM-15T SPRCKT	1
*	TS371	ROLLER CHAIN, #60HE X 88 1000 RPM- 3T SPRCKT	1
9	TS40	LINK/CONNECTOR #60HE	1
10	TS29	SPROCKET/IDLER ASSY.	1
11	TS84	SPROCKET/ASSY 20T	1
12	TS85	BRONZE BUSHING	1
13	TS86	EXPELLER SOLID SHEAR HUB	1
14	T73	SPACER	A/R
15	F129	TIGHTENER WASHER	2
16	TS329	EXPELLER DRIVE SPACER	1
17	S36	SHIM	A/R
*	S409	SHIM	A/R
18	S138	KEY	2
19	YSKP10010	SCREW SOCKET HEAD, 5/16 X 3/8	4





**FIGURE 6**  
**INPUT SHAFT/EXPELLER DRIVE**







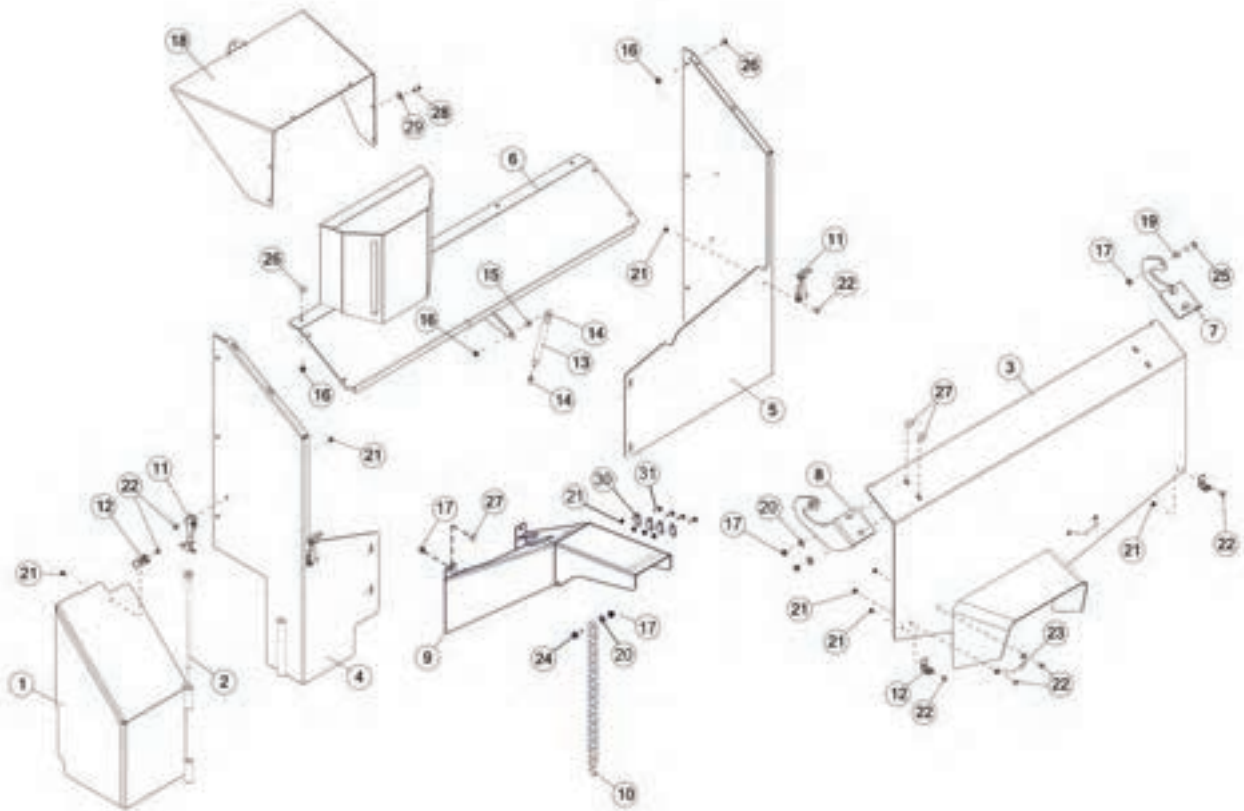
# FIGURE 6

## INPUT SHAFT/EXPELLER DRIVE

REF #	PART #	DESCRIPTION	QTY
20	YSKP12010	SCREW SOCKET HEAD, 3/8 X 1/2	2
21	YBHH08027	BOLT HEX, 1/4 X 1-1/2 G8	6
22	YBHH16080	BOLT HEX, 1/2 X 2 - 1/2 G5	1
23	YBHH18005	BOLT HEX, 9/16 X 1-1/2 G5	8
24	YBHH20055	BOLT HEX, 5/8 X 3-1/2 G5	1
25	YWLO20005	WASHER LOCK, 5/8	1
26	YNHX20005	NUT HEX, 5/8	1
27	YNJM12005	NUT HEX, JAM, 3/8	1
28	YNSF18005	NUT FLANGE, 9/16	8
29	YNTL08005	NUT HEX, TOP LOCK, 1/4	2
30	YNTL16005	NUT HEX, TOP LOCK, 1/2 540 RPM PTO	1









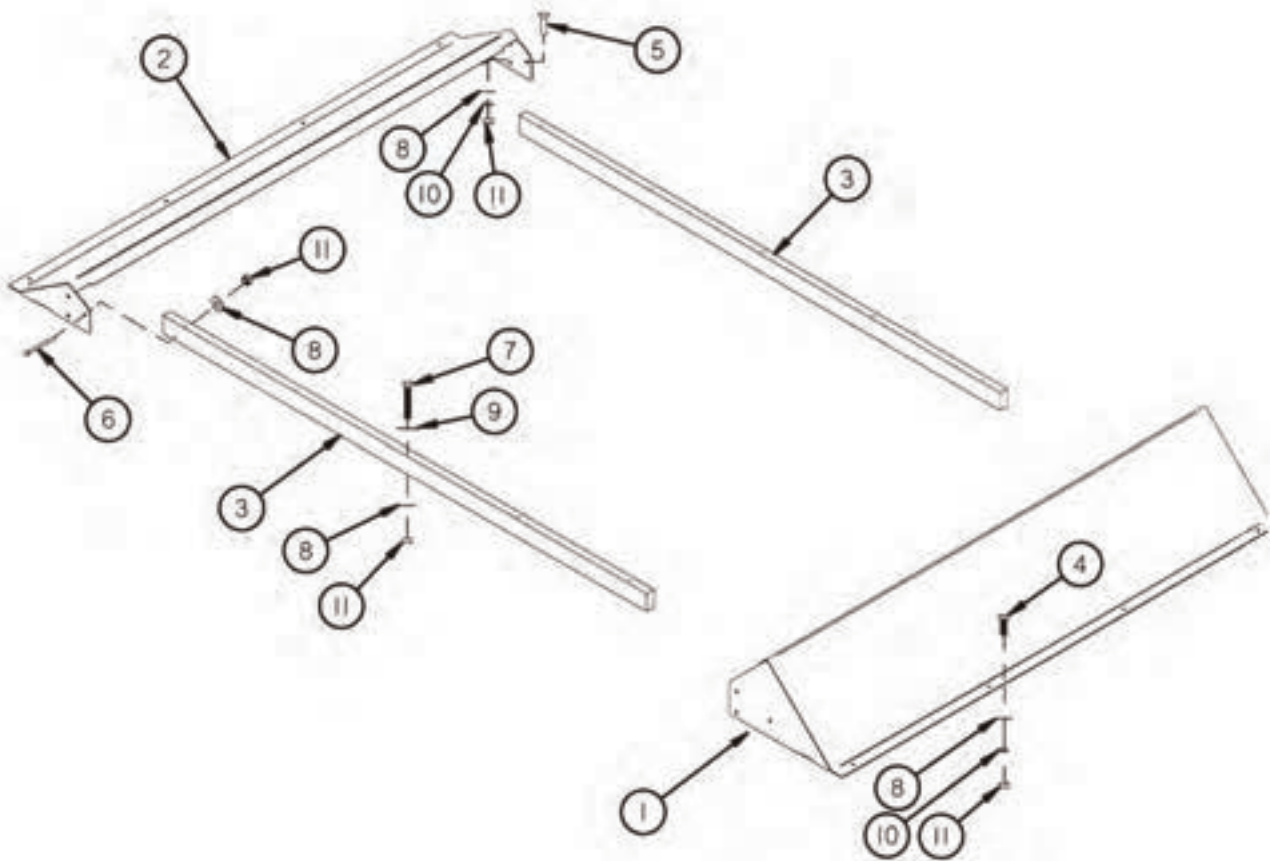
# FIGURE 7 GUARDS/SHIELDS

REF #	PART #	DESCRIPTION	QTY
1	TS87B	DRIVE SHIELD W/DECALS	1
2	TS88	SHIELD HINGE	1
3	TS89B	FRONT SHIELD DOOR W/DECALS	1
4	TS90	FRONT SHIELD RH	1
5	TS91	FRONT SHIELD LH	1
6	TS92B	FRONT SHIELD TOP W/DECALS	1
7	TS93	FRONT SHIELD HINGE RH	1
8	TS94	FRONT SHIELD HINGE LH	1
9	98259B	HOSE HOLDER W/DECALS	1
10	TS130	CHAIN PTO HOLDER	1
11	X233	COMPLETE LATCH	3
12	X193	LATCH CATCH	3
13	TS97	GAS SPRING	1
14	TS381	STEEL BALL SOCKET	2
15	TS382	BALL MOUNT	1
16	YNFG10005	NUT FLANGE, 5/16 GF	13
17	YNFG12006	NUT FLANGE, 3/8 GF	6
18	57325	FILLER SHIELD	1
19	TS331	SHIELD HINGE SPACER	2
20	YWFL12005	WASHER FLAT, 3/8	2
21	YNFG08010	NUT FLANGE , 1/4 GF	13
22	YBHH08100	BOLT HEX, 1/4 X 3/4 G5	9
23	TS96	HANDLE	2
24	YBFB12125	BOLT FLANGE, 3/8 X 1-1/4 G5	2
25	YBFB12150	BOLT FLANGE, 3/8 X 1-1/2 G5	2
26	YBCR10030	BOLT CARRIAGE, 5/16 X 3/4 G5	9
27	YBCR12010	BOLT CARRIAGE, 3/8 X 1 G5	6
28	YSDR08005	SCREW SELF DRILLING , 1/4 X 1	7
29	YWFL10005	WASHER FLAT, 5/16	6
30	77200	PLATE, 1.75 X 1.50 X 0.19	4
31	YBFB08075	BOLT FLANGE, 1/4 X 3/4 G5	4





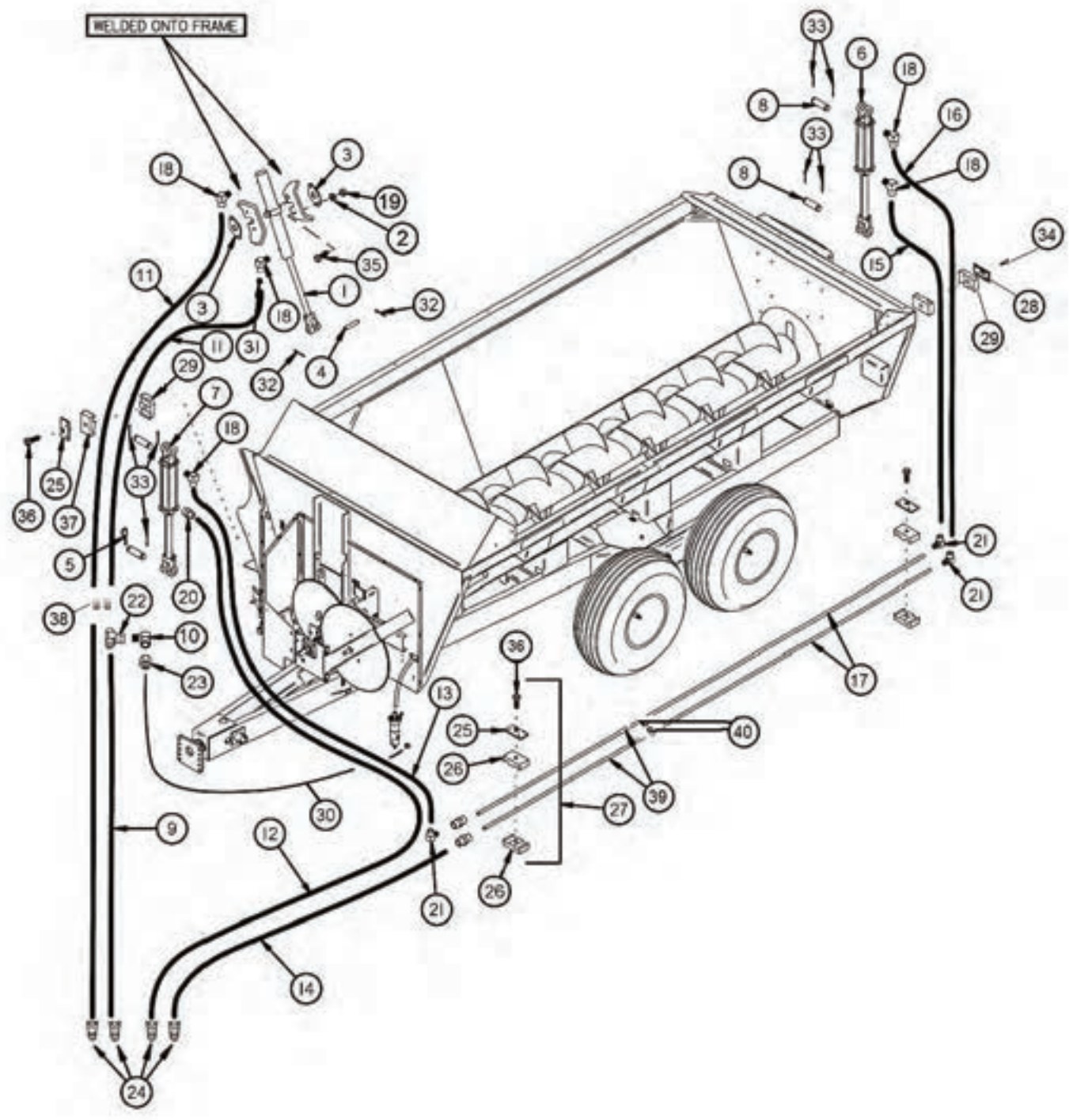
**FIGURE 8**  
**SPLASH GUARDS/RAILS**







# FIGURE 9 HYDRAULICS







# FIGURE 9

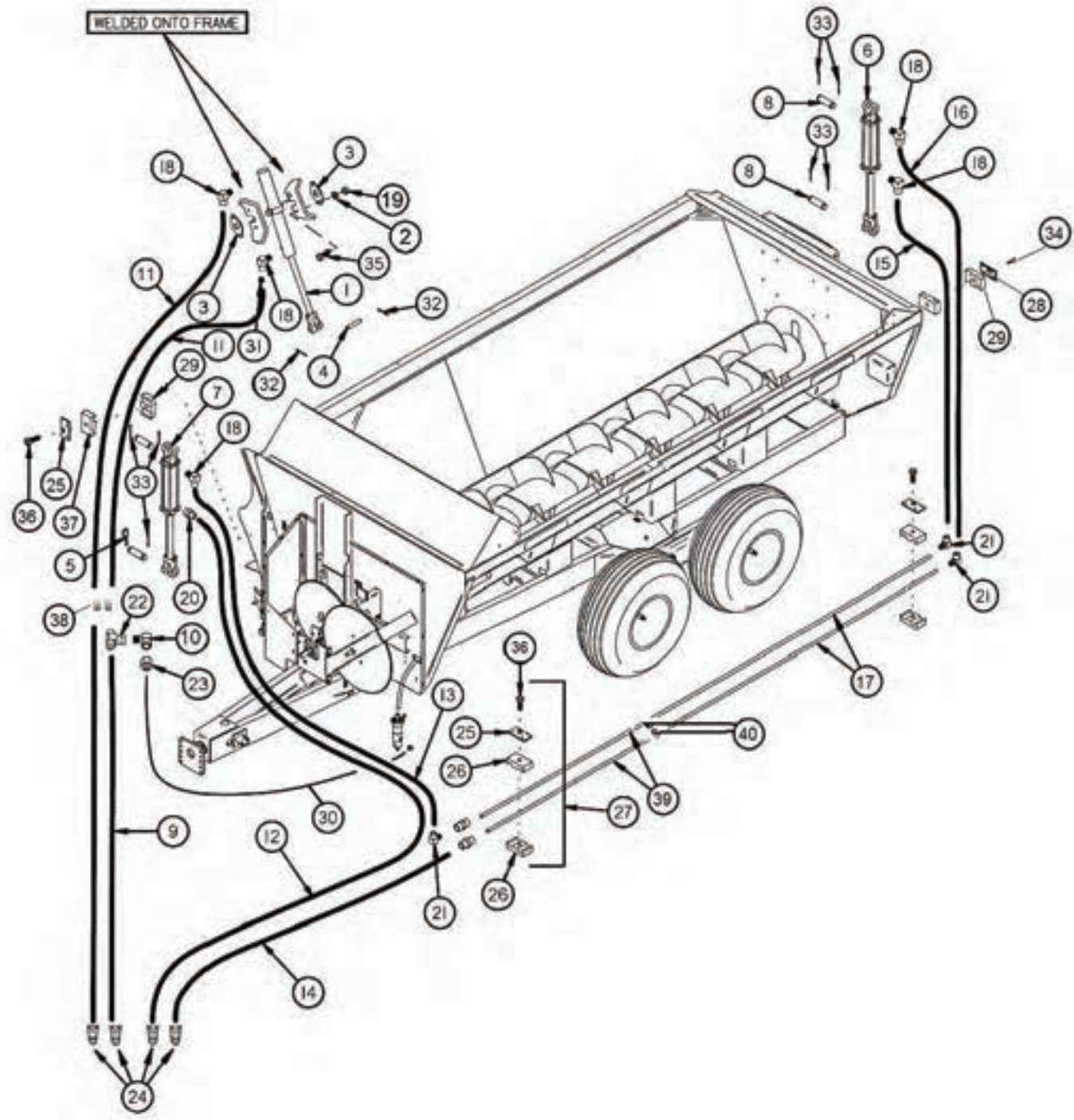
## HYDRAULICS

REF #	PART #	DESCRIPTION	QTY
1	TS101	CYLINDER	1
*	72197	KIT, O-RING SEALS	1
2	YWLO12005	WASHER LOCK, 3/8	4
3	TS103	CYLINDER MOUNT CLIP	2
4	LW55	CYLINDER PIN	1
5	YPHR02010	HAIR PIN	1
6	TS105	CYLINDER	1
*	72230	O-RING SEALS KIT	1
7	TS104	CYLINDER	1
*	72207	KIT, O-RING SEALS	1
8	T143	CYLINDER PIN	4
9	85664	HYDRAULIC HOSE, 6, 94IN	2
10	58127	FITTING 6 C6X-S	1
11	85430	HYDRAULIC HOSE, 6, 125IN	2
12	TS111	HYD. HOSE 1/2 X 162 -8 JIC & 1/2 MP	1
13	TS112	HYD. HOSE 1/2 X 56 -8 JIC & -8 JIC	1
14	TS113	HYD. HOSE 1/2 X 120 -8 JIC & 1/2 MP	1
15	TS114	HYD. HOSE 1/2 X 38 -8 JIC & -8 JIC	1
16	TS115	HYD. HOSE 1/2 X 49 -8 JIC & -8 JIC	1
17	89070	HYDRAULIC TUBE, 1/2 X 120	2
18	CHM206	FITTING, 90, 6JIC X 8ORB	3
19	YNHX12005	HEX NUT, 3/8	4
20	TS137	-8 MALE O-RING TO -8 MALE JIC	1
21	TFM83	-8 FEMALE JIC SWIVEL TO -8 MALE JIC 90°	3
22	CHM242	TEE SWIVEL RUN	1
23	73993	FITTING STRAIGHT, 6JIC, 6NPTF, STL	1
24	DWM205	QUICK COUPLER MALE	4
25	56563	CLAMP TOP PLATE	12
26	TS118	LINE CLAMP BLOCK	6
27	TFM91	DOUBLE STEEL LINE CLAMP	3
28	56564	CLAMP TOP PLATE	6
29	56596	CLAMP CUSHION (SET OF 2)	6
30	86383	HYDRAULIC HOSE, 4, 78 IN	1
31	58142	FITTING, 6 XHX7-S .031 ORIFICE	1
32	YPCT05010	COTTER PIN, 5/32 X 1-1/2	2
33	YPCT06005	COTTER PIN, 3/16 X 1-1/2	7
34	56569	BOLT HEX, 5/16 X 1-3/4 G5	6
35	YBHH12030	BOLT HEX, 3/8 X 1-1/4 G5	4
36	56568	BOLT HEX, 5/16 X 1-3/8 G5	12





**FIGURE 9**  
**HYDRAULICS**





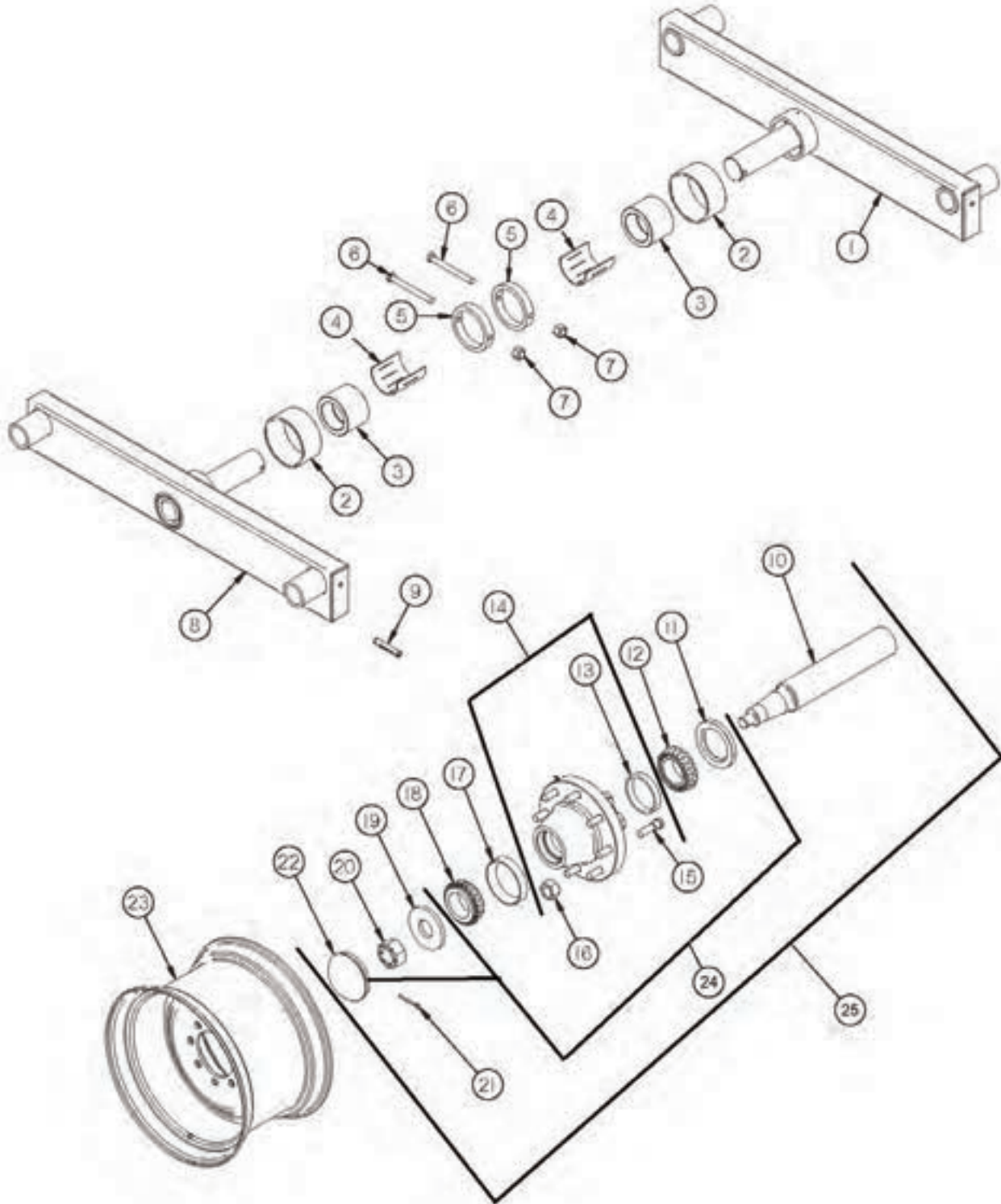
# FIGURE 9 HYDRAULICS

REF #	PART #	DESCRIPTION	QTY
37	CHM278	CLAMP HALF 3/8 HOSE (SET OF 2)	7
38	CHM258	UNION (6 HTX-S)	2
39	89076	HYDRAULIC TUBE, 1/2 X 77	2
40	GM17	ADAPTER (8 HTX)	2





**FIGURE 10**  
**5220 TANDEM AXLES**





# FIGURE 10

## 5220 TANDEM AXLES

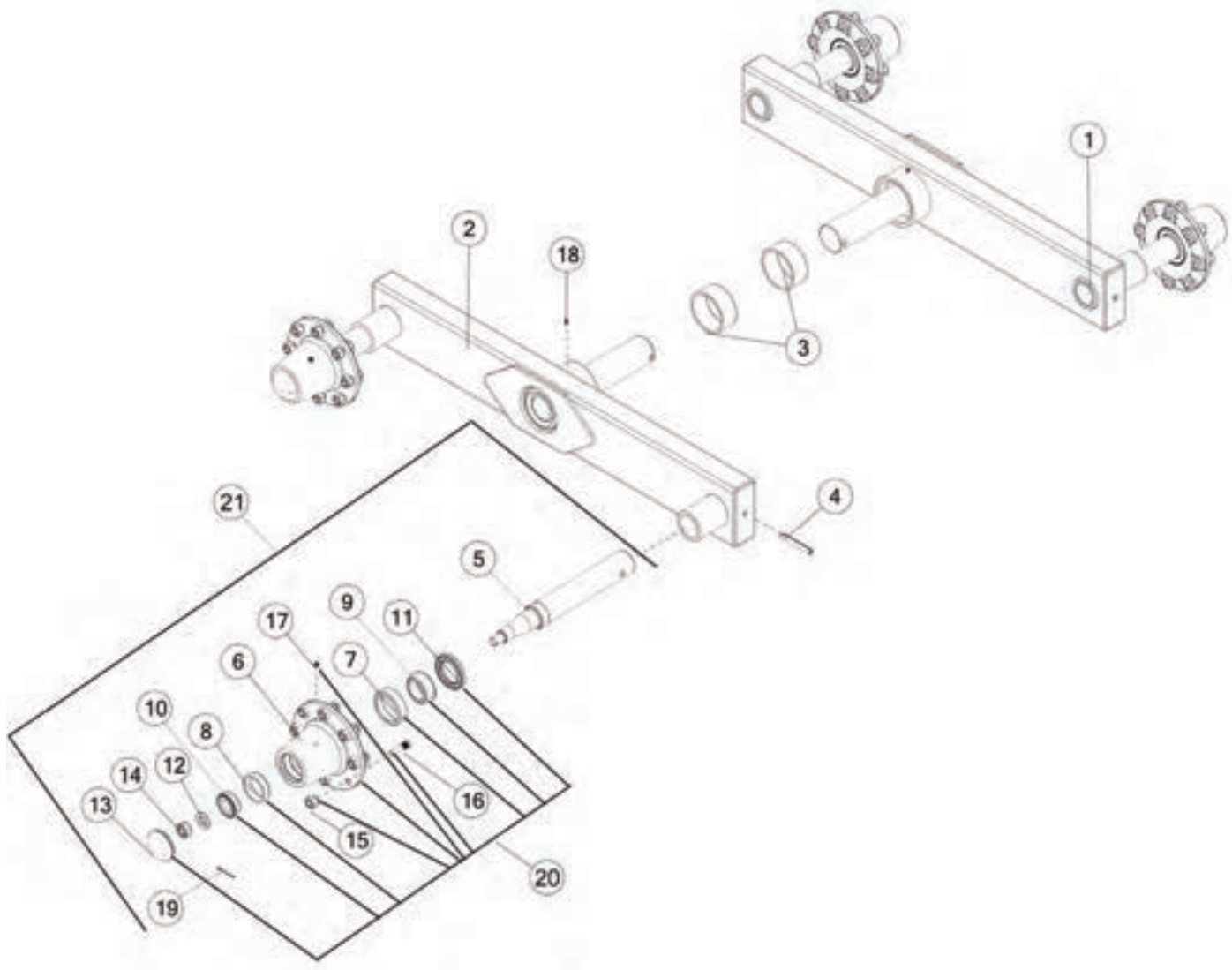
REF #	PART #	DESCRIPTION	QTY
1	TS314	TANDEM MID LH	1
*	TS132	TANDEM BEAM LH	1
*	TS131	LEFT TANDEM DROP	1
2	70162	NYLATRON BUSHING	2
3	70150	NYLATRON BUSHING	4
4	57806	SPACER	2
5	16SV78	COLLAR FOR AXLE	2
6	YBFB16500	BOLT FLANGE, 1/2 X 5 G5	2
7	YNFG16003	NUT FLANGE, 1/2	2
8	TS315	TANDEM MID RH	1
*	TS134	TANDEM BEAM RH	1
*	TS133	RIGHT TANDEM DROP	1
9	YPEX16020	EXPANSION PIN, 1/2 X 4	4
10	16SV203	SPINDLE	4
11	B90	SEAL	4
12	B91	INNER BEARING	4
13	B91A	INNER RACE	4
14	53403	HUB SUBASSEMBLY	4
15	YBSD20010	STUD BOLT, 5/8 X 2-1/2	32
16	YNWL20005	WHEEL NUT, 5/8	32
17	B94A	OUTER RACE	4
18	B94	OUTER BEARING	4
19	YWFL28005	WASHER	4
20	YNSL28005	NUT HEX, SLOTTED, 7/8	4
21	YPCT05020	COTTER PIN, 5/32 X 1-3/4	4
22	B2	HUB CAP	4
23	23N179ASR	WHEEL 8.25 X 22.5 8 BOLD SILVER	4
24	26G4A	HUB ASSEMBLY	4
25	92424	HUB AND SPINDLE ASSEMBLY	4
*	12V36SR	WHEEL 14 X 16.1 SILVER	4







**FIGURE 11**  
TSSA OPTIONAL TANDEM





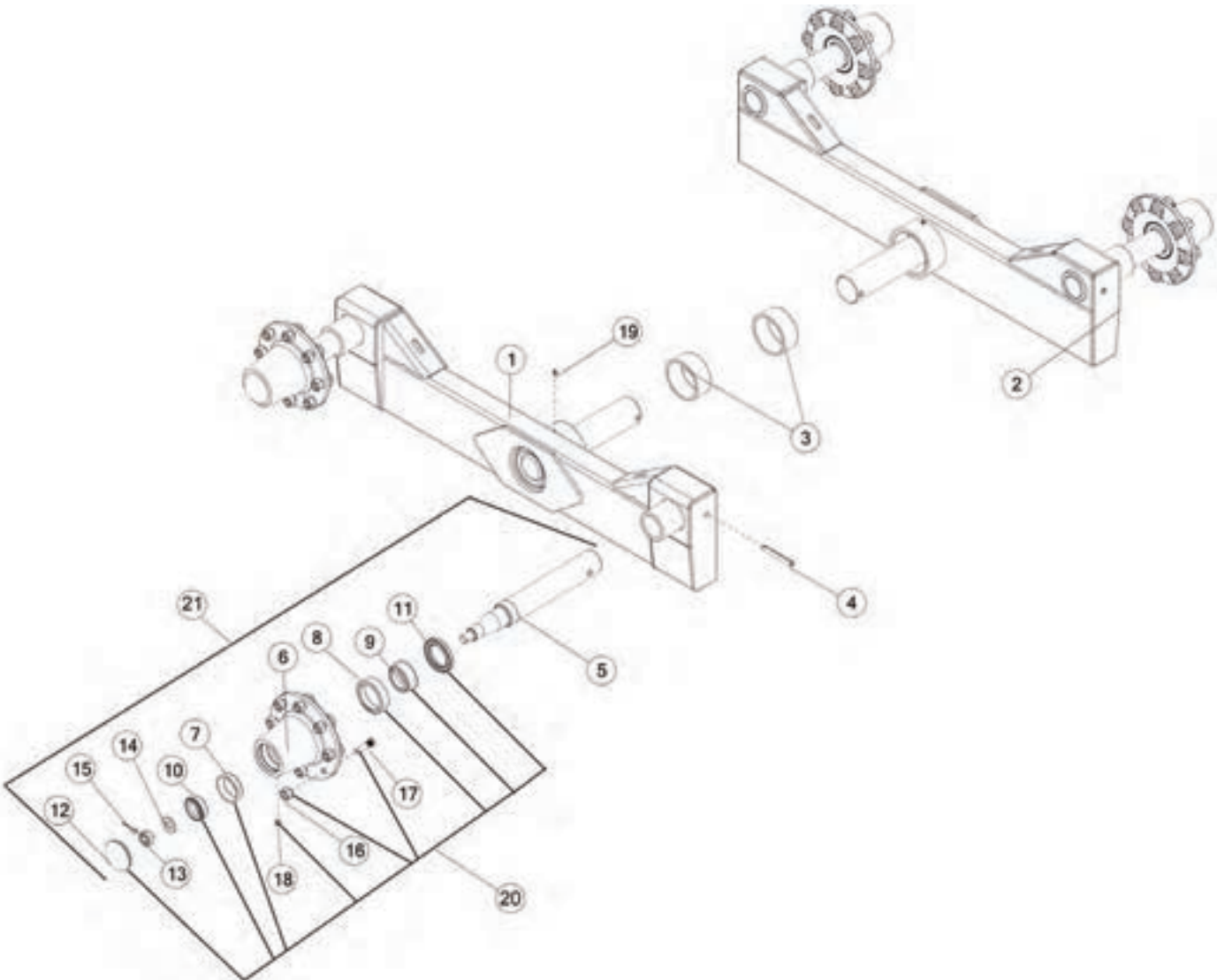
**FIGURE 11**  
**TSSA OPTIONAL TANDEM**

REF #	PART #	DESCRIPTION	QTY
1	TS132	STRAIGHT TANDEM LH	1
2	TS134	STRAIGHT TANDEM RH	1
3	70162	BUSHING, NYLATRON,4.50 OD X 4.01 ID X 1.88	2
4	YPEX16020	EXPANSION PIN, 1/2 X 4	4
5	16SV203	SPINDLE	4
6	53403	HUB SUBASSEMBLY	4
7	B91A	INNER RACE	4
8	B94A	OUTER RACE	4
9	B91	INNER BEARING	4
10	B94	OUTER BEARING	4
11	B90	GREASE SEAL	4
12	YWFL28010	WASHER FLAT, SAE 7/8	4
13	B2	HUB CAP	4
14	YNSL28005	NUT SLOT, 7/8-14 NA G2 NF	4
15	YNWL20005	NUT WHEEL, 5/8-18 NA G5 ZC	32
16	YBSD20010	STUD BOLT, 5/8-18 UNF X 2-1/2	32
17	BFR28	GREASE ZERK, 1/8 NPT	2
18	G89	STRAIGHT ZERK, 1/4-28	2
19	YPCT05020	COTTER PIN, 5/32 X 1-3/4	4
20	26G4A	HUB ASSEMBLY	4
21	92424	HUB & SPINDLE ASSEMBLY	4





**FIGURE 12**  
TSDA OPTIONAL TANDEM



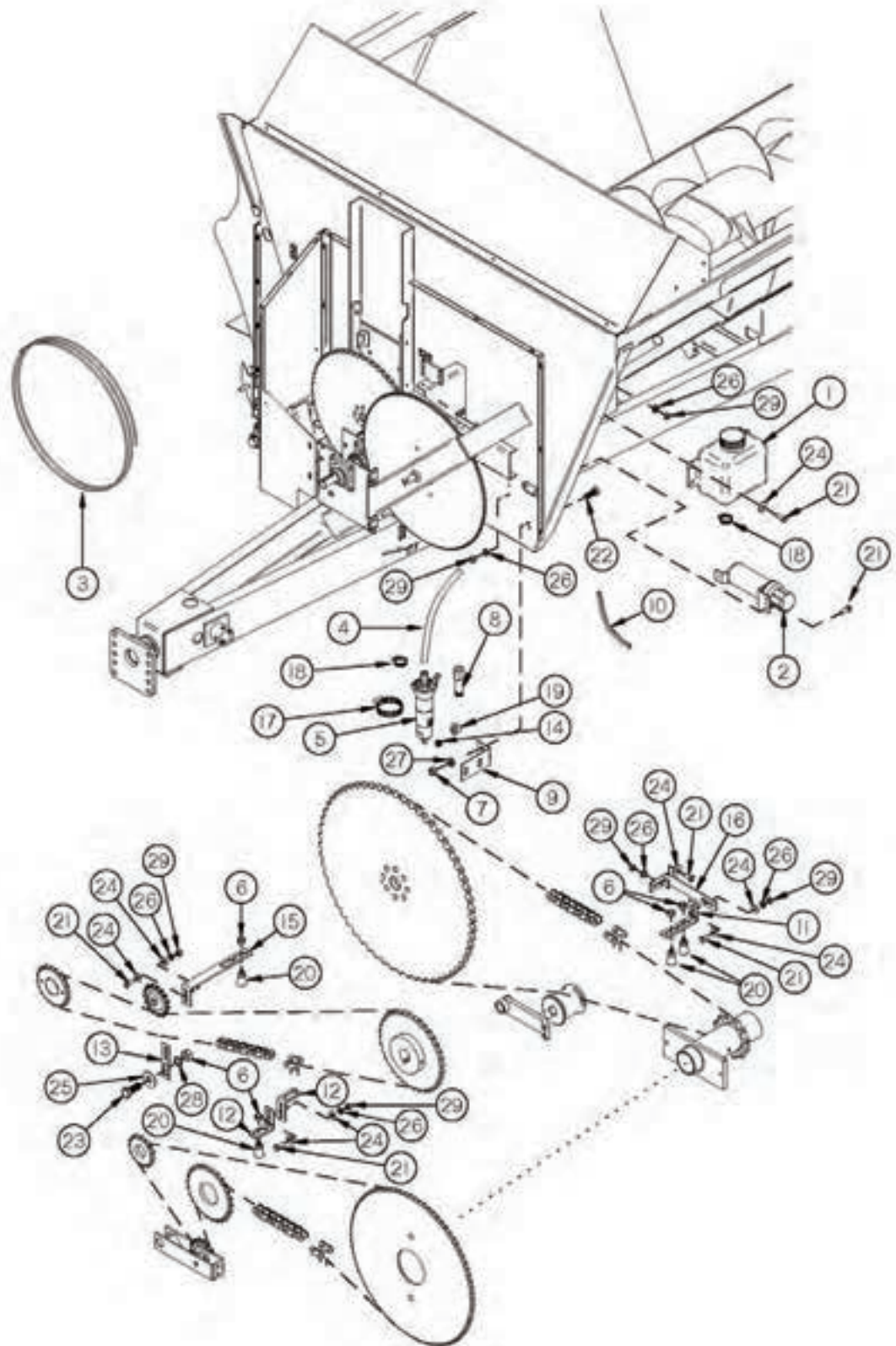


# FIGURE 12

## TSDA OPTIONAL TANDEM

REF #	PART #	DESCRIPTION	QTY
1	TS131	DROP TANDEM LH	1
2	TS133	DROP TANDEM RH	1
3	70162	BUSHING, NYLATRON,4.50 OD X 4.01 ID X 1.88	2
4	YPEX16020	EXPANSION PIN, 1/2 X 4	4
5	16SV203	SPINDLE	4
6	53403	HUB SUB ASSEMBLY	4
7	B94A	OUTER RACE	4
8	B91A	INNER RACE	4
9	53461	INNER BEARING	4
10	53462	OUTER BEARING	4
11	B90	GREASE SEAL	4
12	B2	HUB CAP	4
13	YNSL28005	NUT SLOT, 7/8-14 NA G2 NF	4
14	YWFL28010	WASHER FLAT, SAE 7/8	4
15	YPCT05020	COTTER PIN, 5/32 X 1-3/4	4
16	YNWL20005	NUT WHEEL, 5/8-18 NA G5 ZC	32
17	YBSD20010	STUD BOLT, 5/8-18 UNF X 2-1/2	32
18	BFR28	GREASE ZERK, 1/8 NPT	4
19	G89	STRAIGHT ZERK, 1/4 -28	2
20	26G4A	HUB ASSEMBLY	4
21	92424	HUB & SPINDLE ASSEMBLY	4









# FIGURE 13

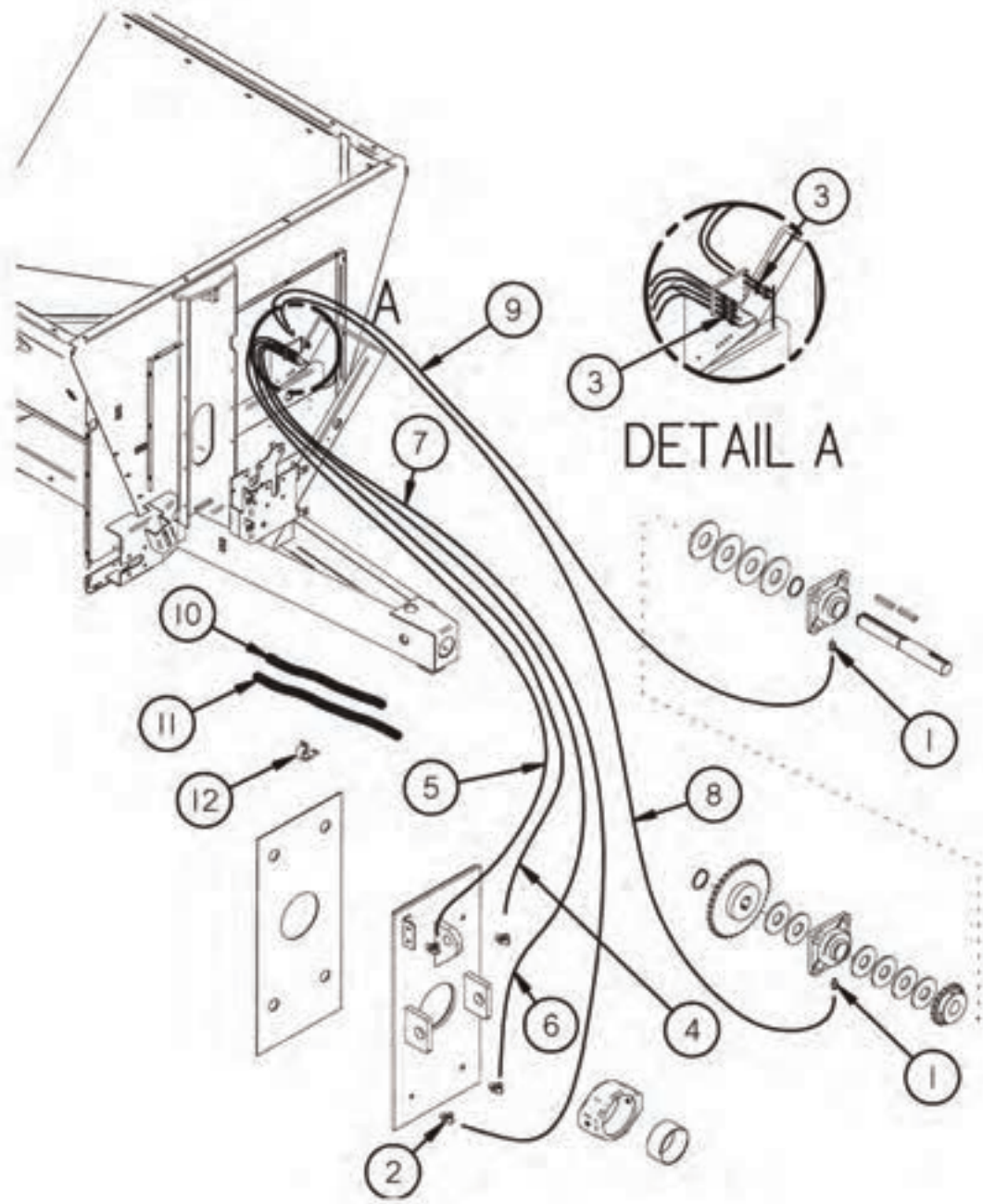
## OILER KIT

REF #	PART #	DESCRIPTION	QTY
1	HGV63	RESERVOIR	1
2	S522	MANUAL HOLDER	1
3	HGV71	OIL TUBE	1
4	HGV66	FILLER HOSE	1
5	HGV82	PUMP	1
6	YNHX16005	NUT HEX, 1/2	5
7	YNHX12005	NUT HEX, 3/8	2
8	HGV84	MANIFOLD ASSEMBLY	4
9	HGV68	PUMP MOUNT BRACKET	1
10	HGV77	EDGING	1
11	HGV69	BRUSH BRACKET LONG OILER	2
12	TS98	BRUSH BRACKET SINGLE	2
13	HGV70	BRACKET MOUNT	1
14	TS198	ORIFICE .015	1
15	TS322	BRACKET	1
16	TS196	OILER HANGER	1
*	HGV62	COMPLETE OILER KIT	1
17	HGV74	HOSE CLAMP	1
18	HGV75	HOSE CLAMP	2
19	HGV65	ELBOW	1
20	HGV67	BRUSH	4
21	YBHH08100	BOLT, 1/4 X 3/4 G5	11
22	YBHH12135	BOLT, 3/8 X 3/4 G5	2
23	YBHH16045	BOLT, 1/2 X 1-1/4 G5	1
24	YWFL08005	WASHER FLAT, 1/4	11
25	YWFL16005	WASHER FLAT, 1/2	1
26	YWLO08005	WASHER LOCK, 1/4	11
27	YWLO12005	WASHER LOCK, 3/8	2
28	YWLO16005	WASHER LOCK, 1/2	1
29	YNHX08005	NUT HEX, 1/4	11



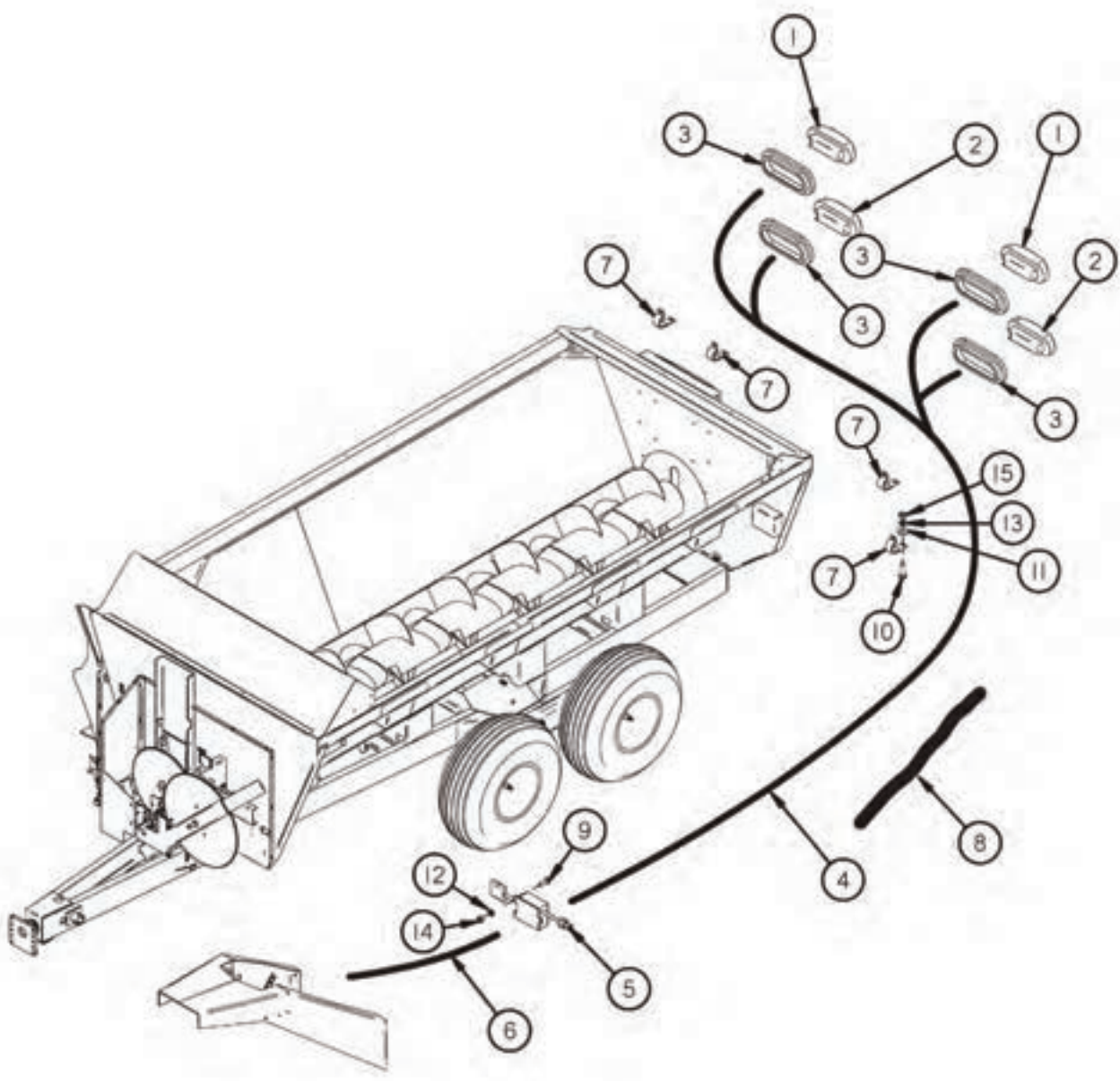


**FIGURE 14**  
**FRONT GREASE LINES**



REF #	PART #	DESCRIPTION	QTY
1	TS323	PIPE ADAPTER	2
2	GM30	GREASE LINE ADAPTER	4
3	YNJM04005	JAM NUT, 1/8 A	6
4	TS119	GREASE LINE - 23	1
5	TS120	GREASE LINE - 29.5	1
6	TS121	GREASE LINE - 38.5	1
7	TS122	GREASE LINE - 45.5	1
8	TS123	GREASE LINE - 60	1
9	TS124	GREASE LINE - 63.75	1
10	TS246	SPLIT LOOM 3/4 X 18	1
11	TS305	SPLIT LOOM 3/4 X 24	1
12	HGV162	RUBBER WIRE HOLDER	1







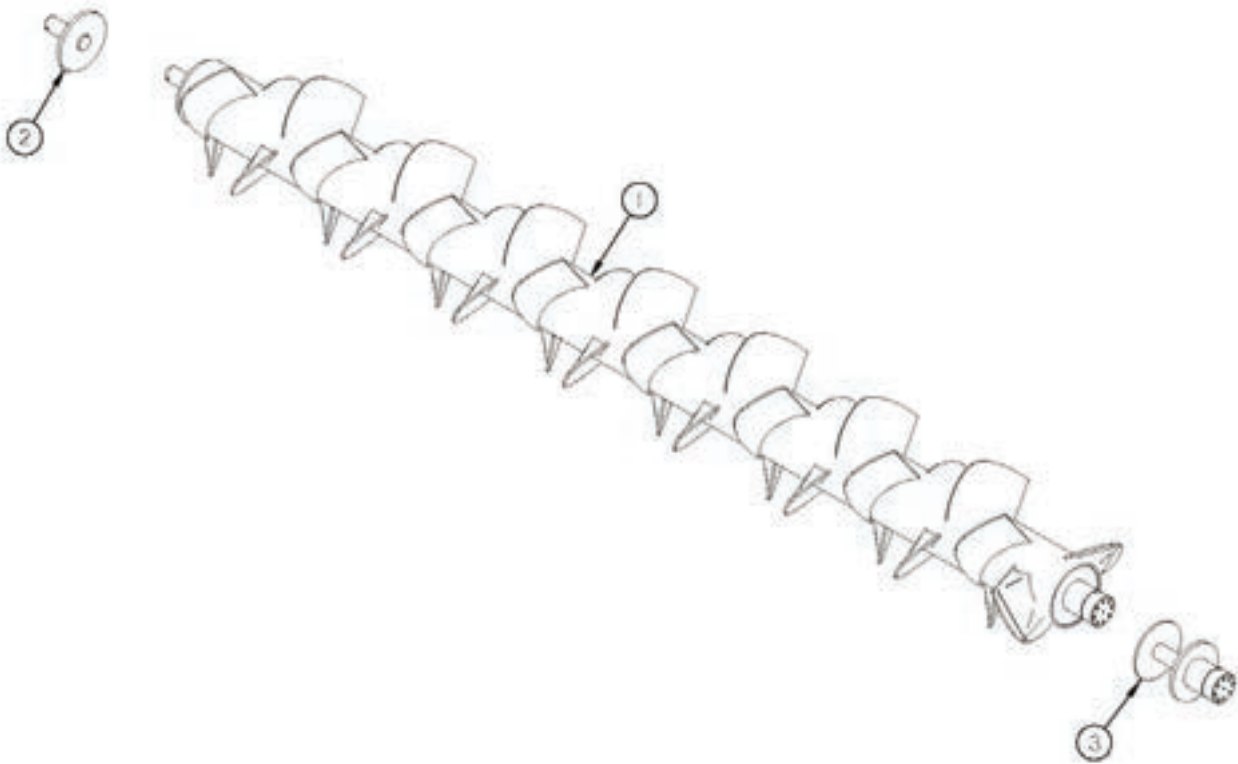
# FIGURE 15

## LIGHTING

REF #	PART #	DESCRIPTION	QTY
1	S309	YELLOW HAZARD LIGHT	2
2	S310	RED TAIL LIGHT	2
3	S308	RUBBER LIGHT MOUNT	4
4	56N155	TAIL LIGHT LOOM	1
5	69908	MODULE	1
6	TS317	HARNESS	1
7	HGV162	RUBBER WIRE HOLDER	4
8	TS129	SPIRAL WRAP, 30	1
9	YSPP64010	PHILLIPS HEAD MACHINE SCREW	3
10	YBHH10105	BOLT HEX, 5/16 X 3/4 G5	4
11	YWFL10005	WASHER FLAT, 5/16	4
12	YWLO08005	WASHER LOCK, 1/4	3
13	YWLO10005	WASHER LOCK, 5/16	4
14	YNHX64005	NUT HEX, #10-32	3
15	YNHX10005	NUT HEX, 5/16	4





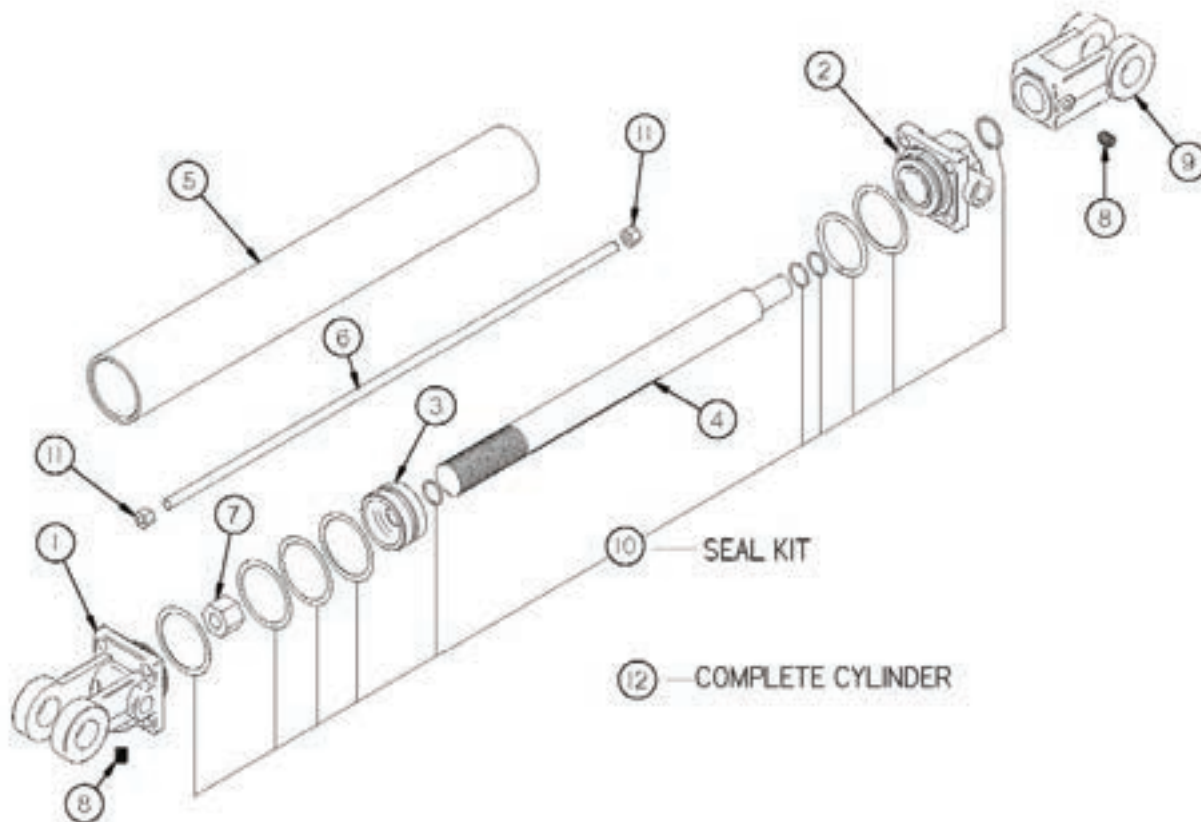


# FIGURE 16

AUGER

REF #	PART #	DESCRIPTION	QTY
1	TS1	AUGER	1
2	TS127	AUGER REAR ASSY.	1
3	TS128	AUGER INPUT ASSY.	1







# FIGURE 17

## AUGER FRONT/REAR HYDRAULIC CYLINDER

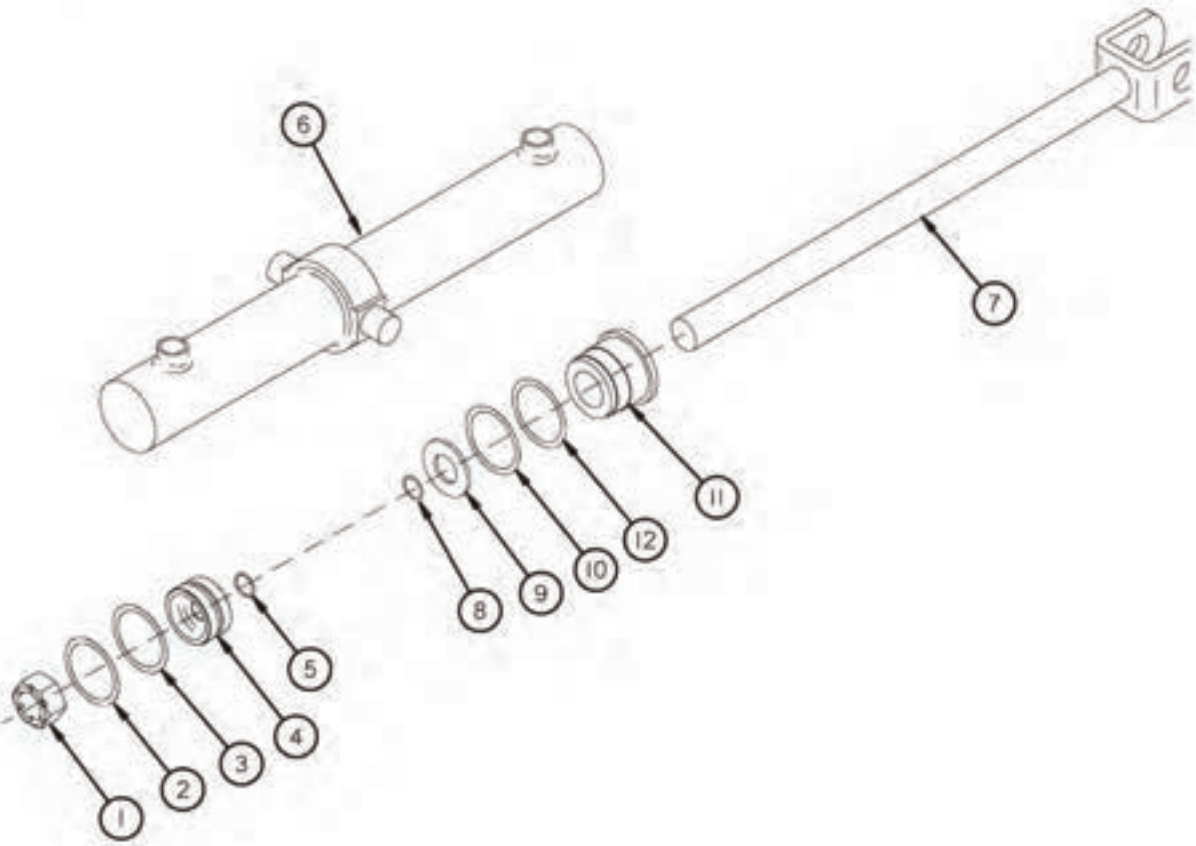
REF #	3" BORE	3-1/4" BORE	DESCRIPTION	QTY
1	TS160	TS176	BASE	1
2	TS158	TS174	HEAD	1
3	TS159	TS175	PISTON NUT	1
4	TS156	TS172	ROD	1
5	TS157	TS173	TUBE	1
6	TS153	TS171	TIE ROD	4
7	TS145	TS166	PISTON NUT	1
8	TS152	TS152	PLUG	1
9	TS155	TS155	CLEVIS ASSEMBLY	1
10	TS163	TS177	SEAL KIT	1
11	TS144	TS165	TIE ROD NUT	8
12	TS104	---	CYLINDER	1
*	---	TS105	CYLINDER	1





# FIGURE 18

EXPELLER DOOR TRUNNION MOUNT  
HYDRAULIC CYLINDER



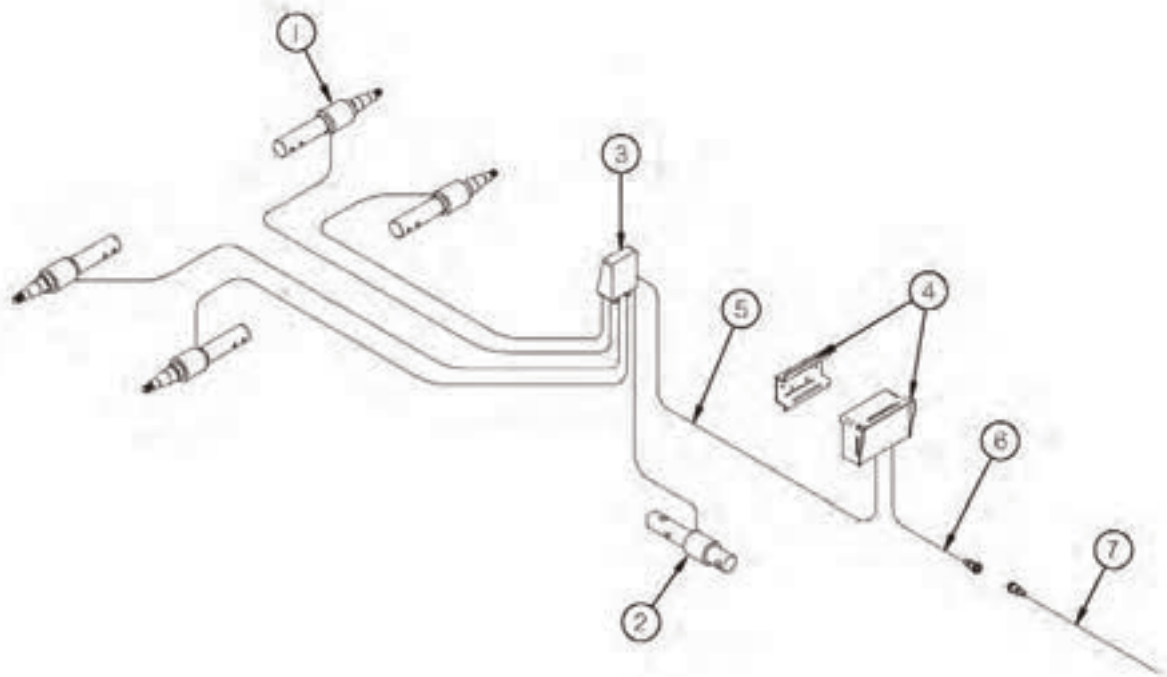




# FIGURE 18 EXPPELLER DOOR TRUNNION MOUNT HYDRAULIC CYLINDER

REF #	PART #	DESCRIPTION	QTY
1	YNSL24010	NUT HEX, SLOTTED, 3/4	1
2	TS344	WEAR RING	1
3	TS345	CAPPED T-SEAL	1
4	TS346	PISTON	1
5	TS347	O-RING	1
6	TS348	JACKET ASSEMBLY	1
7	TS349	PISTON ROD	1
8	TS350	O-RING	1
9	TS351	BACKUP WASHER	1
10	TS352	POLYPAK	1
11	TS353	GLAND NUT	1
12	TS354	METALLIC WIPER	1
*	TS355	SEAL KIT	1







# FIGURE 19

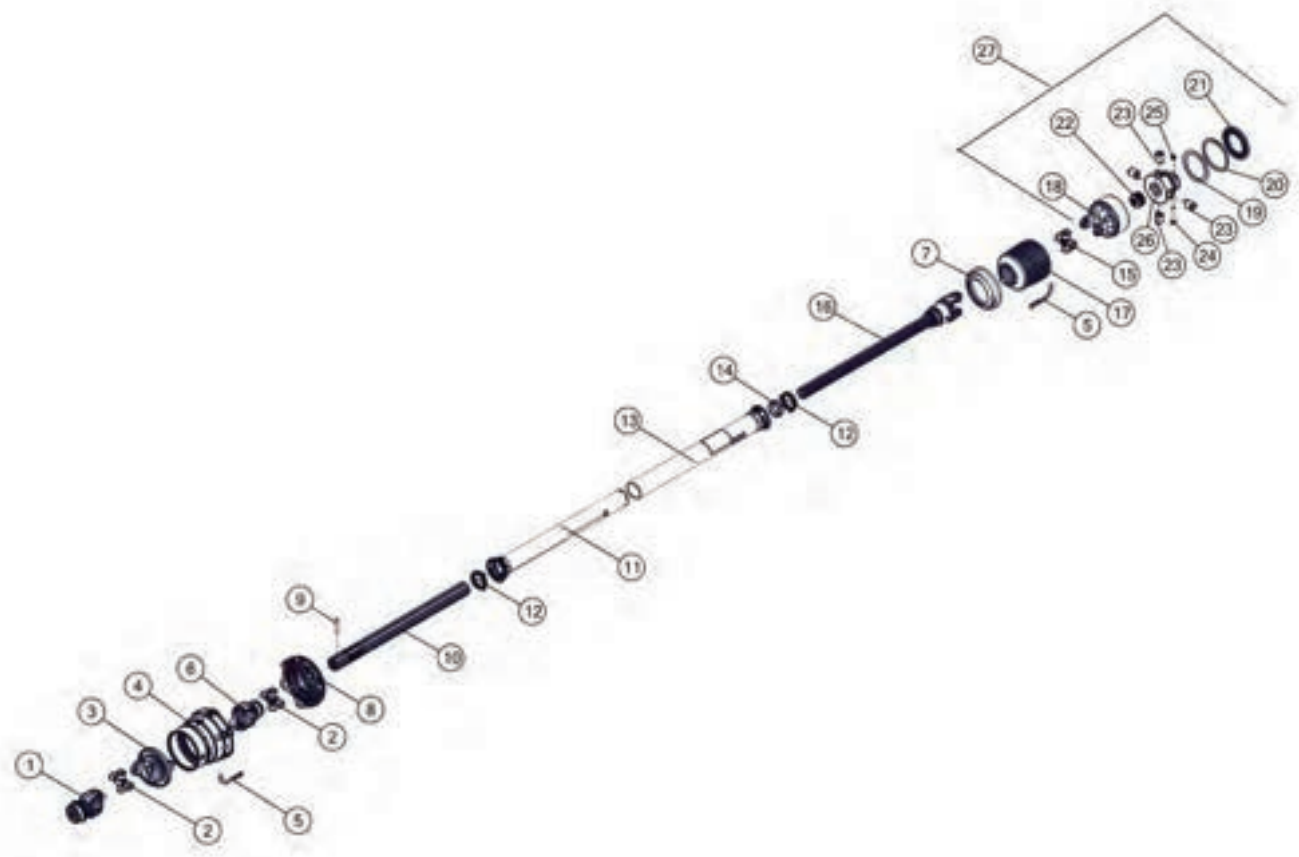
## SCALE

REF #	PART #	DESCRIPTION	QTY
1	TS333	SPINDLE LOAD CELL	4
2	GM403	HITCH LOAD CELL	1
3	TS83	JUNCTION BOX	1
4	GM408	SCALE HANGER BRACKET	1
*	TS337	SCALE DISPLAY W/GPS (OPTIONAL)	1
5	TS338	JUNCTION BOX CORD	1
6	TS385	POWER CORD	1
7	16SV269	TRACTOR POWER CORD	1





**FIGURE 20**  
PTO (540 RPM)





# FIGURE 20

## PTO (540 RPM)

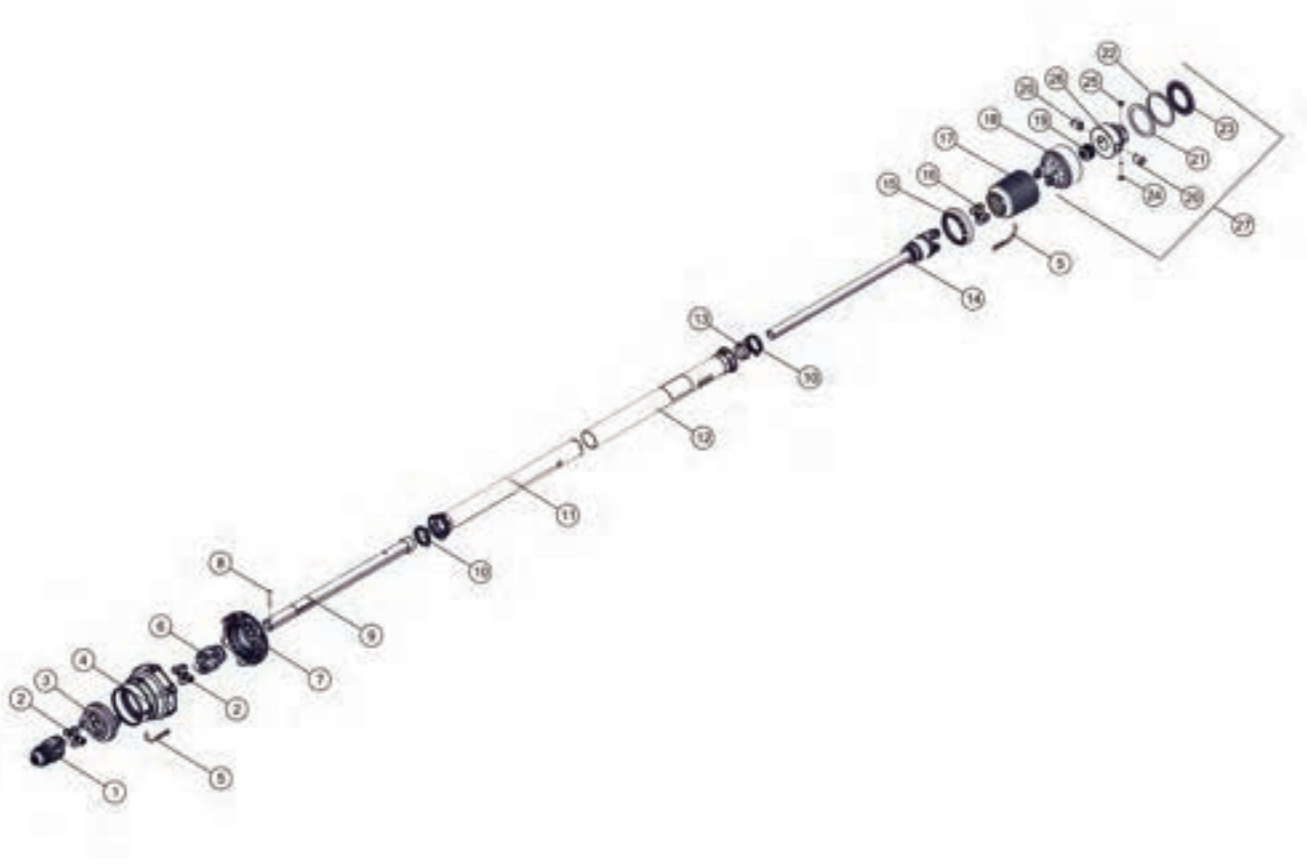
REF #	PART #	DESCRIPTION	QTY
1	93244	YOKE ASSEMBLY	1
2	93245	U JOINT	2
3	93246	DOUBLE YOKE	1
4	92436	CV GUARD	1
5	87916	RESTRAINT CHAIN	2
6	93248	YOKE	1
7	92446	REINFORCING COLLAR	1
8	89776	NET GUARD	1
9	89773	SPRING PIN	1
10	93247	OUTER SHAFT	1
11	93249	INNER TUBE	1
12	87919	BEARING RING	2
13	93251	OUTER TUBE	1
14	92444	BEARING, SUPPORT	1
15	92630	U JOINT	1
16	93250	INNER SHAFT W/ OVERRUNNING CLUTCH	1
17	93252	GUARD CONE	1
18	93253	HOUSING	1
19	93234	WASHER	1
20	93235	RETAINING RING	1
21	93236	SEAL	1
22	93255	SPRING PACK	1
23	93233	CAM	4
24	YBHH16101	BOLT, 1/2 X 2-3/4 GR 8	1
25	YNTL16005	NUT, HEX, 1/2-13, LKTL, C, ZC	1
26	93254	HUB	1
27	93256	CUT-OUT CLUTCH	1
*	93220	COMPLETE PTO, 1-3/8 540 RPM	1







**FIGURE 21**  
OPTIONAL PTO (1000 RPM)





# FIGURE 21

OPTIONAL PTO (1000 RPM)

REF #	PART #	DESCRIPTION	QTY
1	89767	YOKE ASSEMBLY	1
2	89768	CROSS AND BEARING KIT	2
3	89769	DOUBLE YOKE	1
4	89784	CV GUARD	1
5	87916	RESTRAINT CHAIN	2
6	93221	YOKE ASSEMBLY	1
7	89776	NET GUARD	1
8	89773	SPRING PIN	1
9	93238	OUTER SHAFT	1
10	87919	BEARING RING	2
11	93239	INNER TUBE	1
12	93241	OUTER TUBE	1
13	89793	SUPPORT BEARING	1
14	93240	INNER SHAFT W/ OVERRUNNING CLUTCH	1
15	89792	REINFORCING COLLAR	1
16	89786	CROSS AND BEARING KIT	1
17	93225	GUARD CONE	1
18	93230	HOUSING	1
19	93232	SPRING PACK	1
20	93233	CAM	2
21	93234	WASHER	1
22	93235	RETAINING RING	1
23	93236	SEAL	1
24	YBHH16101	BOLT, 1/2 X 2-3/4 GR 8	1
25	YNTL16005	NUT, HEX, 1/2-13, LKTL, C, ZC	1
26	93242	HUB	1
27	93243	CUT-OUT CLUTCH	1
*	93219	COMPLETE PTO, 1-3/8 1000 RPM	1









Manufactured By:

# H&S MANUFACTURING CO., INC.

2608 S. HUME AVE. MARSHFIELD, WI 54449  
(715) 387-3414 | hsmfgco.com

