

# **H&S** PARTS BOOK

# **5226 TOP SHOT MANURE SPREADER**



Revision #06  
Starting Ser. #122TS26001

HSMFGC1220

PART#73356

Manufactured by  
**H&S MANUFACTURING CO., INC.**  
2608 S. HUME AVE. MARSHFIELD, WI 54449  
(715) 387-3414 | [hsmfgco.com](http://hsmfgco.com)



# CONTENTS

Instructions for Ordering Parts - About Improvements . . . . .	1
Figure 1 - Auger/Liner/Slides/Hitch . . . . .	2-5
Figure 2 - Auger Drive . . . . .	6-9
Figure 3 - Expeller/Discharge Gate/Bearings . . . . .	10-11
Figure 4 - Expeller/Discharge Gate/Door . . . . .	12-13
Figure 5 - Expeller/Discharge Gate/Pan . . . . .	14-15
Figure 6 - Input Shaft/Expeller Drive . . . . .	16-19
Figure 7 - Guards/Shields . . . . .	20-21
Figure 8 - Splash Guards/Rails . . . . .	22-23
Figure 9 - Hydraulics . . . . .	24-25
Figure 10 - Tandem Axles 3" Spindle. . . . .	26-27
Figure 11 - Oiler Kit. . . . .	28-29
Figure 12 - Front Grease Lines. . . . .	30-31
Figure 13 - Lighting. . . . .	32-33
Figure 14 - Auger. . . . .	34-35
Figure 15 - Auger Front/Rear Hydraulic Cylinder 2" x 16" . . . . .	36-37
Figure 16 - Expeller Door Hydraulic Cylinder . . . . .	38-39
Figure 17 - Scale. . . . .	40-41
Figure 18 - Optional PTO (540 RPM) . . . . .	42-43
Figure 19 - PTO (1000 RPM). . . . .	44-45
Figure 20 - Optional Tandem Axles . . . . .	46-47
Figure 21 - Optional Tire & Wheel . . . . .	48-49
Figure 22 - Optional Discharge Deflector Hydraulic. . . . .	50-51
Figure 23 - Optional Tire & Electric Valve For Discharge Deflector Hyd. Cyl. . . . .	52-53
Parts Notes . . . . .	54

# **INSTRUCTIONS FOR ORDERING PARTS**

All service parts should be ordered through your authorized H&S dealer. He will be able to give you faster service if you will provide them with the following:

1. Model & Serial Number - Both can be located on the front main frame, below the PTO.
2. All references to left or right apply to the machine as viewed from the rear.
3. Parts should not be ordered from illustration only. Please order complete part number.
4. If your dealer has to order parts - give shipping instructions:

VIA truck - large pieces (please specify local truck lines)

VIA United Parcel Service (include full address)

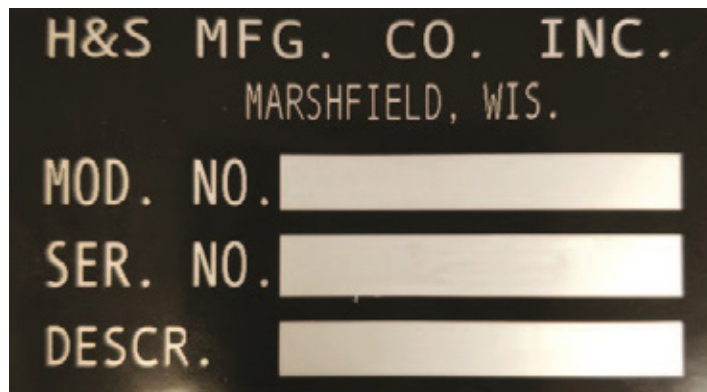

PLEASE RECORD NUMBERS FOR YOUR UNIT FOR QUICK REFERENCE

## **ABOUT IMPROVEMENTS**

H&S IS CONTINUALLY STRIVING TO IMPROVE ITS PRODUCTS

We must, therefore, reserve the right to make improvements or changes whenever it becomes practical to do so, without incurring any obligation to make changes or additions to the equipment previously sold.

# FIGURE 1 AUGER/LINER/SLIDES/HITCH

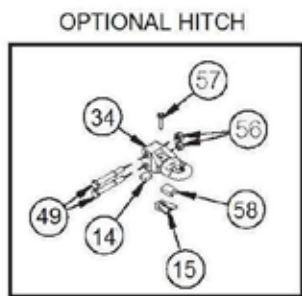
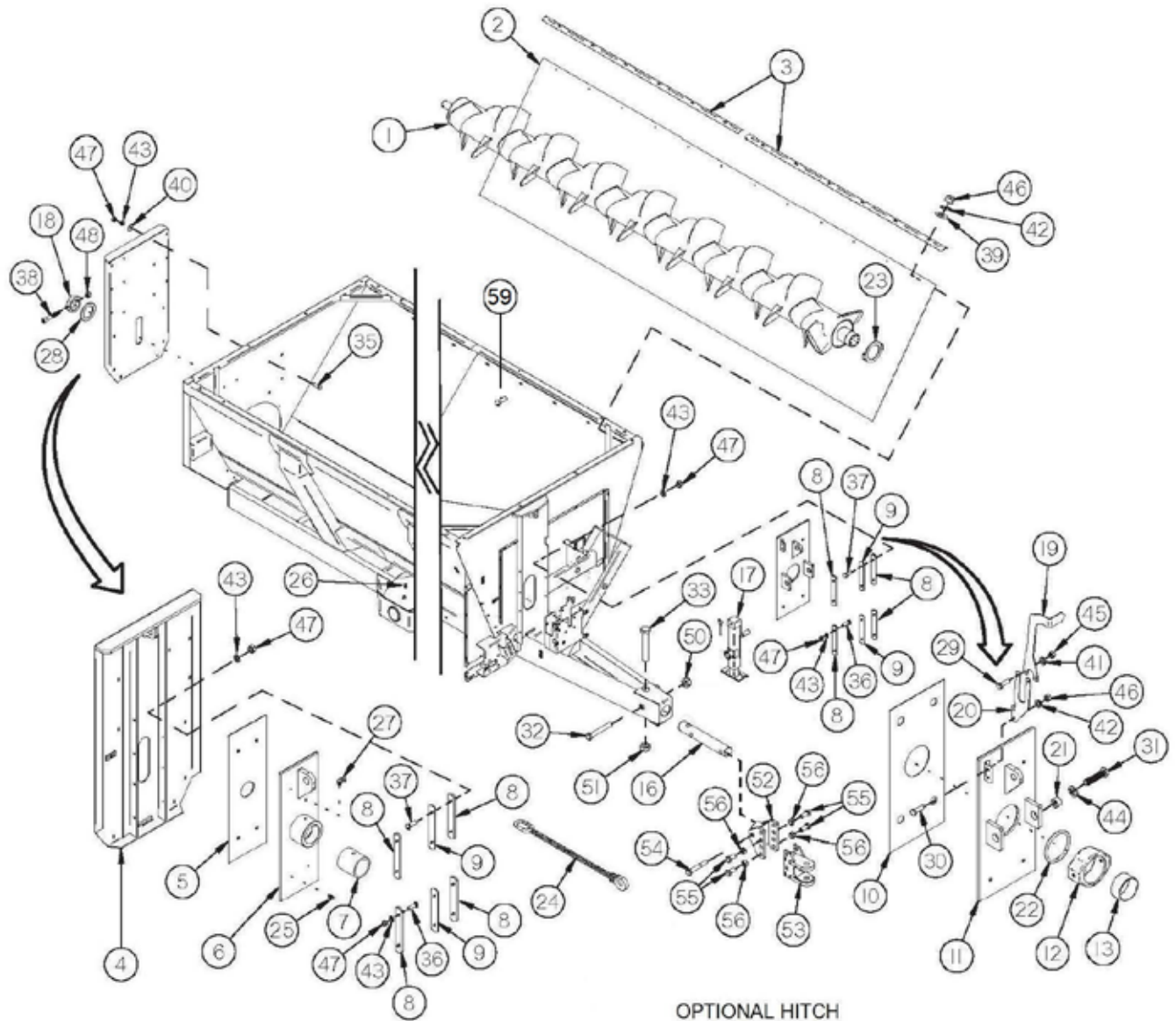

# FIGURE 1

## AUGER/LINER/SLIDES/HITCH

<u>ITEM</u>	<u>QTY</u>	<u>PART#</u>	<u>DESCRIPTION</u>
1	1	TS1	AUGER ASSEMBLY
2	1	TS3	WHITE POLY
3	1	TS4	POLY HOLD DOWN, TOP
4	1	TS6	PANEL, REAR
5	1	TS7	SLIDER POLY, REAR
6	1	TS309	SLIDER, REAR
7	1	TS9	POLY BUSHING
8	8	TS10	SLIDER GUIDE
9	4	TS308	SLIDER GUIDE THIN
10	1	TS11	FRONT POLY SIDE
11	1	TS12	FRONT SLIDE PLATE
12	1	TS14	TRUNION HOUSING
13	1	TS15	FRONT AUGER BEARING
*	1	TS399	TRUNION WITH BEARING
14	1	58554	CUSHION
15	1	58559	TOP PLATE
16	1	GM73	HITCH SHAFT
17	1	TS306	JACK
18	1	TS19	AUGER BACK COLLAR
19	1	TS207	AUGER INDICATOR TOP
20	1	TS208	AUGER INDICATOR BOTTOM
21	2	TS330	TRUNION PIVOT BUSHING
22	1	TS33	AUGER SPROCKET RUBBER GASKET SET
23	1	TS102	TRUNION SPACER
24	1	SC40500	SAFETY CHAIN
25	4	G89	GREASE ZERK, 1/4
26	2	BFR28	GREASE ZERK, 1/8
27	1	RG51	GREASE ZERK, 1/4 90 DEGREE
28	A/R	TS227	SPACER
*	A/R	TS28	SPACER

**\*MEANS NOT SHOWN  
A/R MEANS AS REQUIRED**

# FIGURE 1

## AUGER/LINER/SLIDES/HITCH

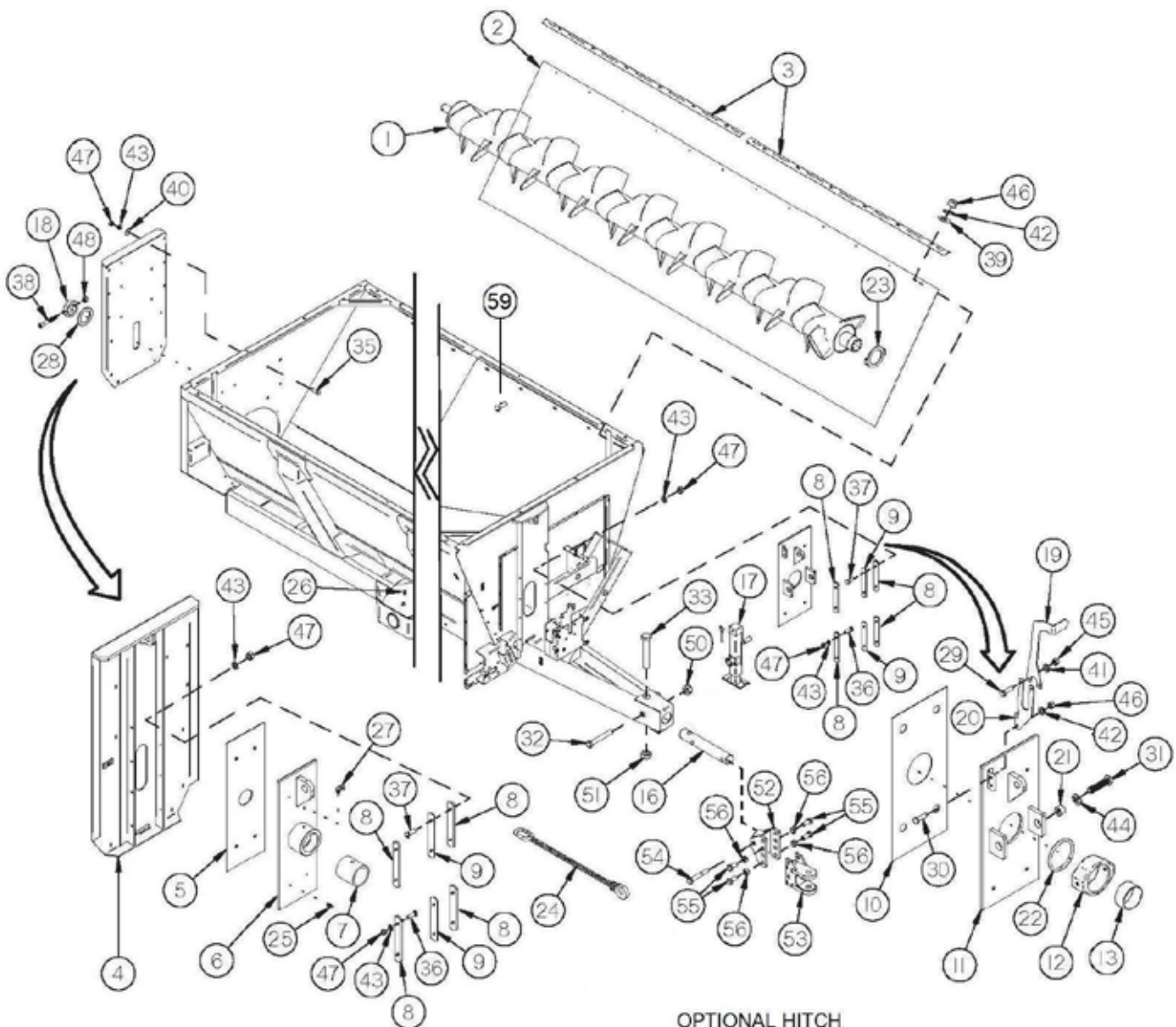

### OPTIONAL HITCH

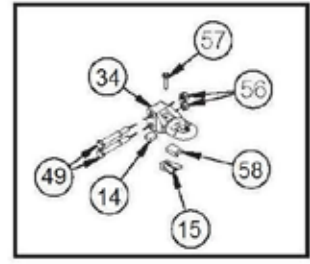

# FIGURE 1

## AUGER/LINER/SLIDES/HITCH

<u>ITEM</u>	<u>QTY</u>	<u>PART#</u>	<u>DESCRIPTION</u>
29	2	YBHH08100	BOLT HEX, 1/4 X 3/4 G5
30	2	YBHH10105	BOLT HEX, 5/16 X 3/4 G5
31	2	YBHH20022	BOLT HEX, 5/8 X 1-3/4 G8
32	1	YBHH24083	BOLT HEX, 3/4 X 5 G8
33	1	YBHH32023	BOLT HEX, 1 X 5 G8
34	1	58557	HITCH
35	18	YBCR12010	BOLT CARRIAGE, 3/8 X 1 G5
36	8	YBCR12020	BOLT CARRIAGE, 3/8 X 1-1/4 G5
37	8	YBCR12015	BOLT CARRIAGE, 3/8 X 1-1/2 G5
38	1	YSHS12018	SCREW SOCKET HEAD, 3/8 X 4
39	12	YWFL10005	WASHER FLAT, 5/16
40	18	YWFL12005	WASHER FLAT, 3/8
41	2	YWLO08005	WASHER LOCK, 1/4
42	14	YWLO10005	WASHER LOCK, 5/16
43	34	YWLO12005	WASHER LOCK, 3/8
44	2	YWLO20005	WASHER LOCK, 5/8
45	2	YNHX08005	NUT HEX, 1/4
46	14	YNHX10005	NUT HEX, 5/16
47	34	YNHX12005	NUT HEX, 3/8
48	1	YNTL12005	NUT HEX, TOP LOCK, 3/8
49	2	YBHH32034	BOLT HEX, 1 X 7-1/2, G8
50	1	YNRL24005	NUT HEX, REVERSIBLE-SIDE LOCK, 3/4
51	1	YNRL32005	NUT HEX, REVERSIBLE-SIDE LOCK, 1
52	1	58532	PINTLE HITCH RECEIVER
53	1	58538	ADJUSTABLE CLEVIS
54	1	YBHH32028	BOLT HEX, 1 X 6-1/2 G8
55	4	YBHH32005	BOLT HEX, 1 X 2-1/2 G5
56	6	YNTL32005	NUT HEX, TOPLOCK, 1
57	1	YBHH24051	BOLT HEX, 3/4 X 3 G5
58	1	58558	V BLOCK
59	12	YBHH10045	BOLT HEX, 5/16 X 1-1/4 G5



# FIGURE 2 AUGER DRIVE

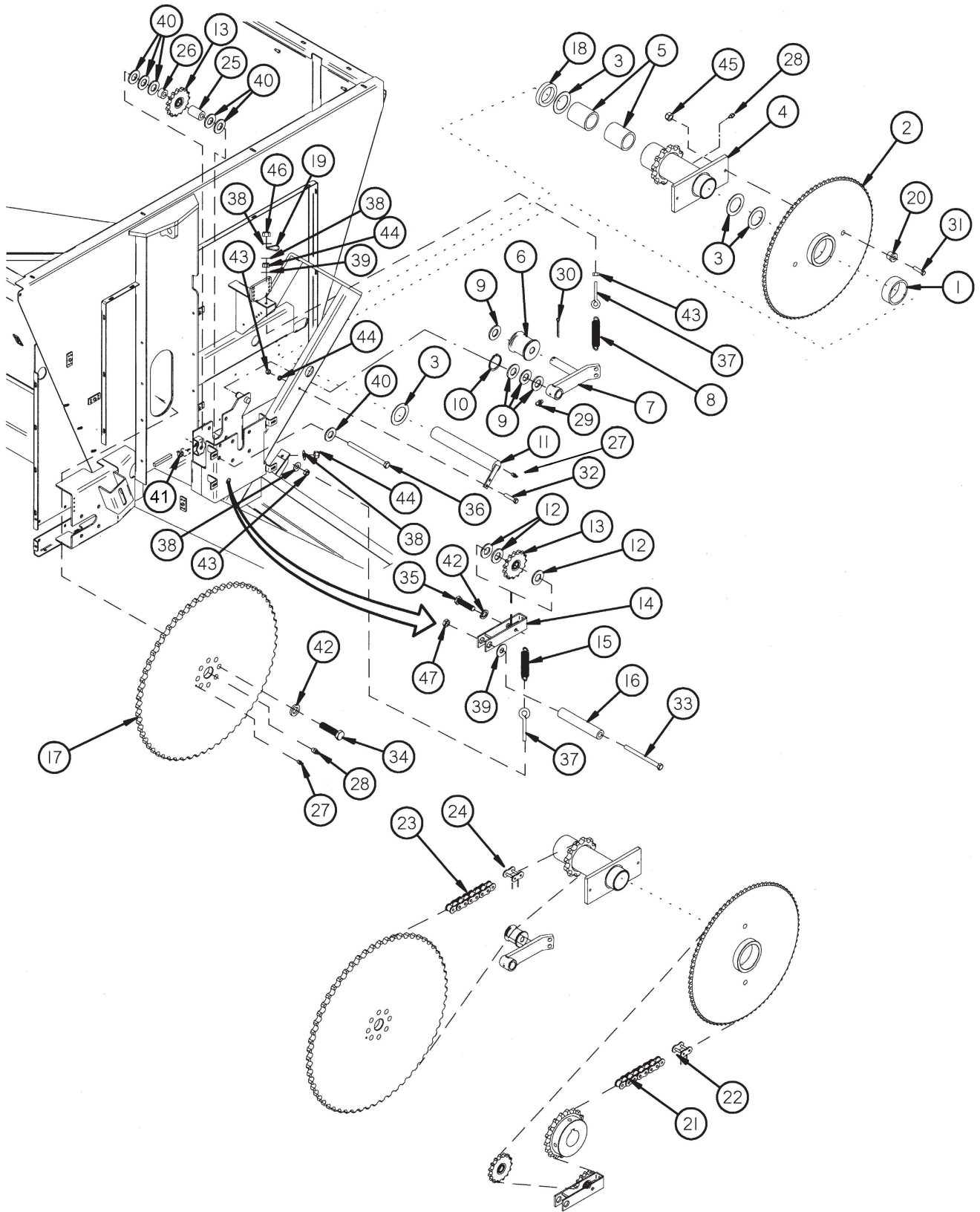



## FIGURE 2 AUGER DRIVE

<u>ITEM</u>	<u>QTY</u>	<u>PART#</u>	<u>DESCRIPTION</u>
1	1	TS20	BRONZE BUSHING
2	1	TS21	SPROCKET 80T (540 RPM)
*	1	TS312	SPROCKET 119T (1000 RPM)
3	A/R	TS22	SPACER
*	A/R	56N183	SPACER
4	1	TS23	COUNTER SHAFT
5	2	73572	BUSHING
6	1	TS25	ROLLER IDLER
7	1	TS26	AUGER CHAIN TENSIONER
8	1	BFR138	SPRING
9	3	S345	SPACER
10	1	3G21	SNAP RING
11	1	73569	SHAFT
12	A/R	T73	SPACER
*	A/R	16SV49	SPACER
13	2	TS29	SPROCKET/IDLER ASSY
14	1	TS30	IDLER ASSY
15	1	ST36	SPRING/EXTENSION
*	1	GM410	SPRING (1000 RPM ONLY)
16	1	TS31	TENSIONER PIVOT TUBE
17	1	TS32	SPROCKET
18	1	TS328	REDUCTION LARGE SPACER
19	1	HGV72	SMALL TUBE HOLDER
20	2	TS34	HARDENED SHEAR BUSHING
21	1	TS39	ROLLER CHAIN #60H X 138 (540 RPM - 18T & 15T SPRCKTS)
*	1	TS360	ROLLER CHAIN #60H X 136 (540 RPM - 13T SPROCKET)
*	1	TS361	ROLLER CHAIN #60H X 140 (540 RPM - 20T SPROCKET)
*	1	TS313	ROLLER CHAIN #60H X 166 (1000 RPM - 15T SPROCKET)
*	1	TS362	ROLLER CHAIN #60H X 165 (1000 RPM - 13T SPROCKET)
*	1	TS363	ROLLER CHAIN #60H X 167 (1000 RPM - 16T SPROCKET)

**\*MEANS NOT SHOWN**

**A/R MEANS AS REQUIRED**

# FIGURE 2 AUGER DRIVE

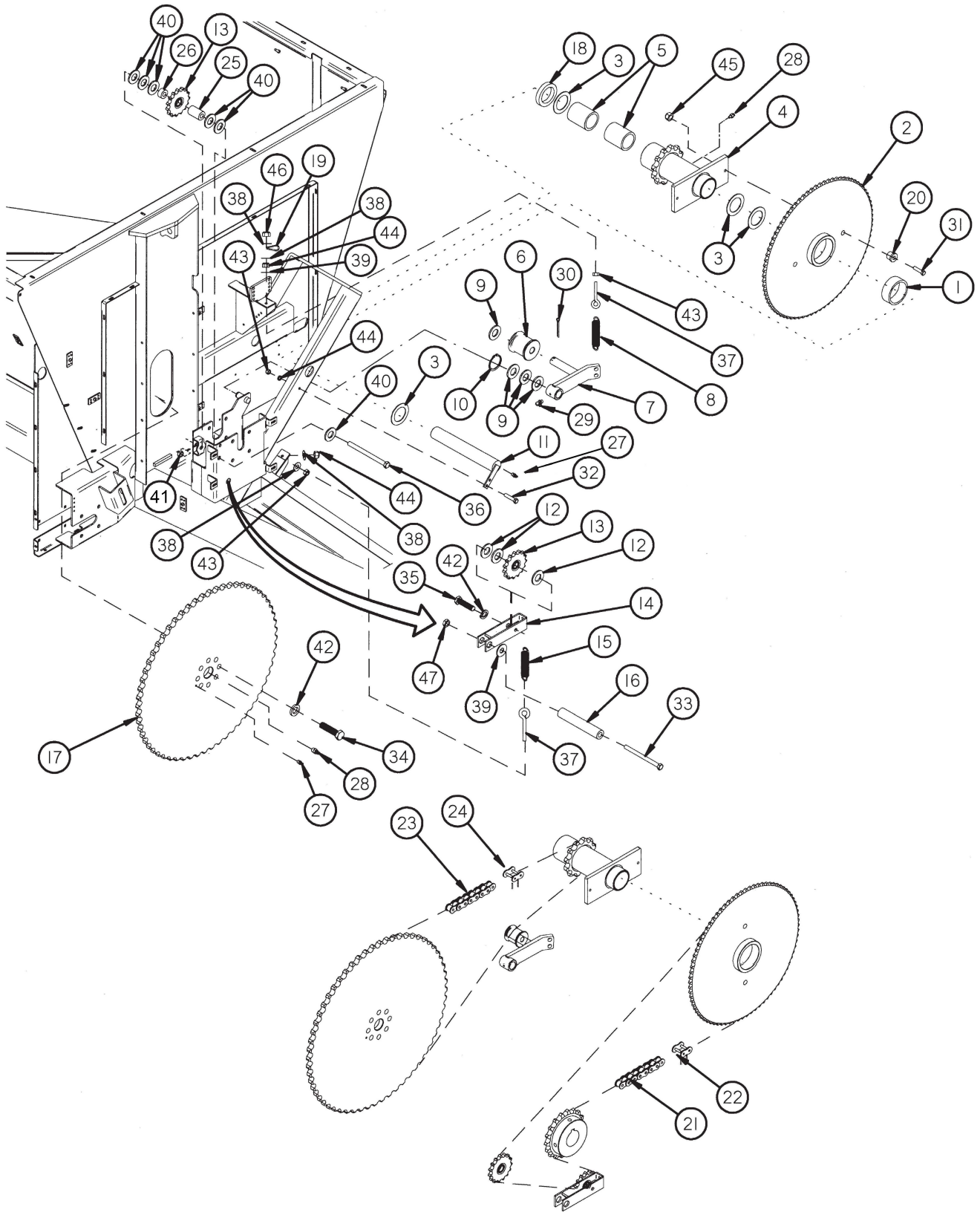

## FIGURE 2 AUGER DRIVE

<u>ITEM</u>	<u>QTY</u>	<u>PART#</u>	<u>DESCRIPTION</u>
22	1	TS40	CONNECTOR LINK #60H
23	1	TS41	ROLLER CHAIN #100HE X 75
24	1	TS42	CONNECTOR LINK #100H
25	1	TS396	IDLER FRONT SPACER
26	1	TS397	IDLER REAR SPACER
27	2	G89	SRAIGHT ZERK, 1/4 90 DEGREE
28	2	BFR28	GREASE ZERK, 1/8
29	1	RG51	GREASE ZERK, 1/4 90 DEGREE
30	1	YPCT06005	COTTER PIN, 3/16 X 1-1/2
31	6	YBHH10036	BOLT HEX, 5/16 X 1-1/2 G8
32	1	YBHH12100	BOLT HEX, 3/8 X 2-1/4 G5
33	1	YBHH16175	BOLT HEX, 1/2 X 6-1/2 G5
34	8	YBHH20036	BOLT HEX, 5/8 X 2-1/2 G8
35	1	YBHH20025	BOLT HEX, 5/8 X 2 G5
36	1	YBHH20100	BOLT HEX, 5/8 X 6 G5
37	2	YBTE12025	BOLT TURNED EYE, 3/8 X 3
38	4	YWFL12005	WASHER FLAT, 3/8
39	2	YWFL16005	WASHER FLAT, 1/2
40	A/R	YWFL20005	WASHER FLAT, 5/8
41	1	YNTJ20005	NUT HEX, TOP LOCK, JAM, 5/8
42	9	YWLO20005	WASHER LOCK, 5/8
43	3	YNHX12005	NUT HEX, 3/8
44	2	YNNY12005	NUT HEX, NYLON LOCKNUT, 3/8
45	6	YNTL10005	NUT HEX, TOP LOCK, 5/16
46	1	YNTL12005	NUT HEX, TOP LOCK, 3/8
47	1	YNTJ16005	NUT HEX, TOP LOCK, JAM, 1/2

**A/R MEANS AS REQUIRED**

# **FIGURE 3** **EXPELLER/DISCHARGE GATE/BEARINGS**

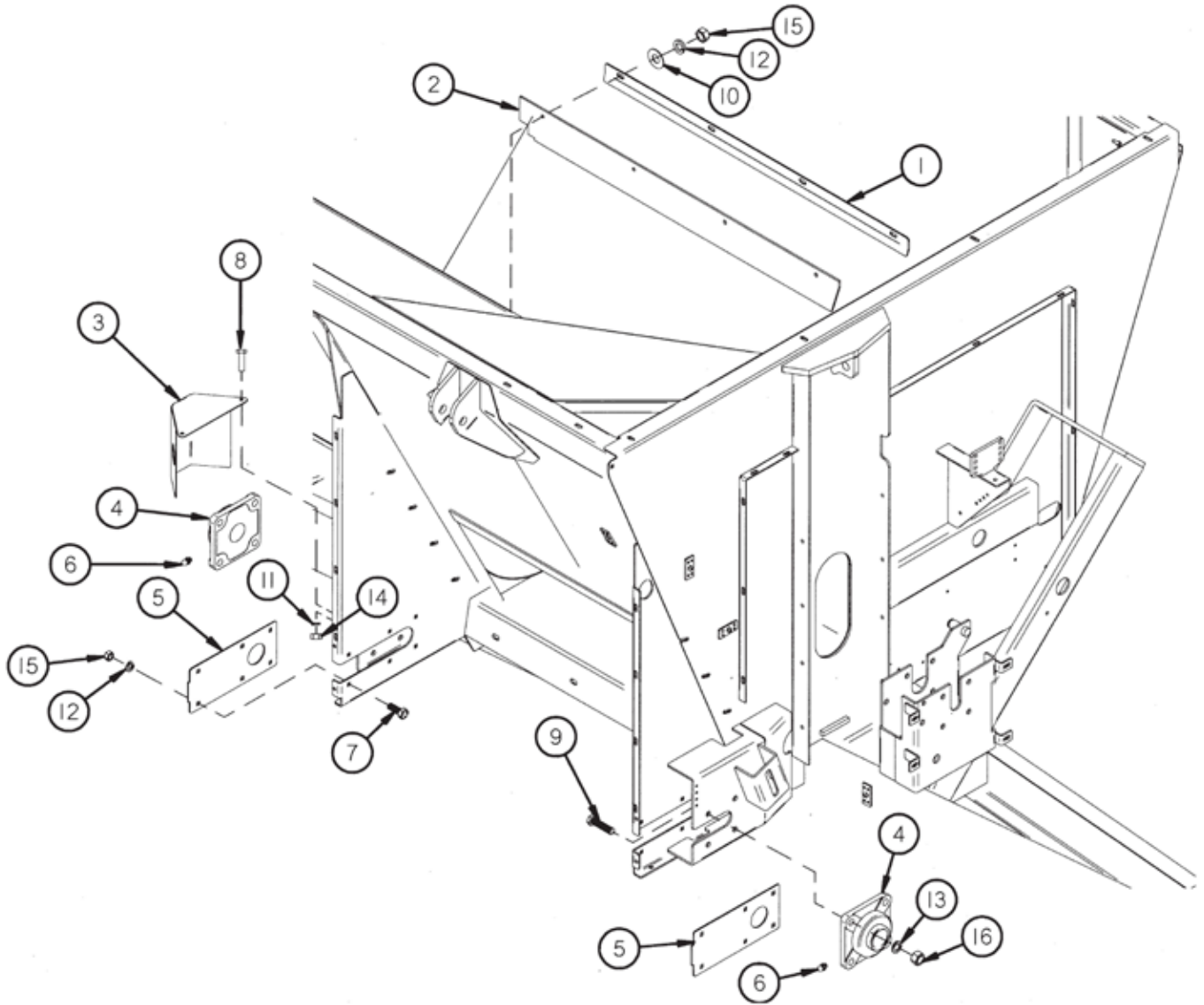

**FIGURE 3**  
**EXPELLER/DISCHARGE GATE/BEARINGS**

<b><u>ITEM</u></b>	<b><u>QTY</u></b>	<b><u>PART#</u></b>	<b><u>DESCRIPTION</u></b>
1	1	TS43	DOOR SEAL CLAMP
2	1	TS44	EXPELLER DOOR TOP SEAL
3	1	TS45	EXPELLER BEARING SHIELD
4	2	HGV41	EXPELLER BEARING
5	2	TS47	COVER PLATE
6	2	G89	GREASE ZERK, 1/4
7	12	YBCR12010	BOLT CARRIAGE, 3/8 X 1 G5
8	2	YBHH08100	BOLT HEX, 1/4 X 3/4 G5
9	8	YBHH18010	BOLT HEX, 9/16 X 1-3/4 G5
10	4	YWFL12005	WASHER FLAT, 3/8
11	2	YWLO08005	WASHER LOCK, 1/4
12	16	YWLO12005	WASHER LOCK, 3/8
13	8	YWLO18005	WASHER LOCK, 9/16
14	2	YNHX08005	NUT HEX, 1/4
15	16	YNHX12005	NUT HEX, 3/8
16	8	YNHX18005	NUT HEX, 9/16

# **FIGURE 4** **EXPELLER/DISCHARGE GATE/DOOR**

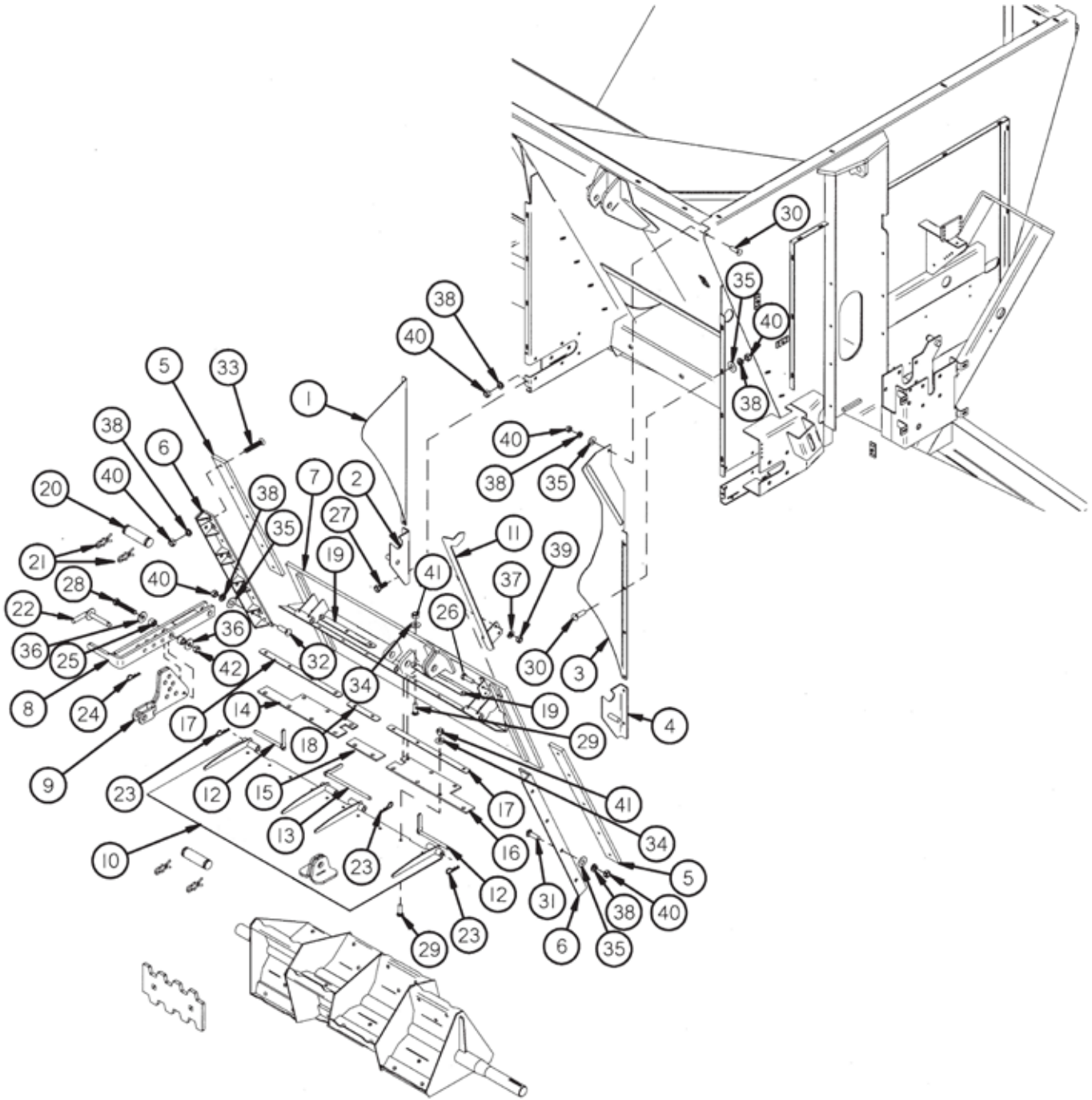

## FIGURE 4

### EXPELLER/DISCHARGE GATE/DOOR

<u>ITEM</u>	<u>QTY</u>	<u>PART#</u>	<u>DESCRIPTION</u>
1	1	TS48	EXPELLER PANEL EXTENSION LH
2	1	TS49	PAN HINGE BRACKET RH
3	1	TS50	EXPELLER PANEL EXTENSION RH
4	1	TS51	PAN HINGE BRACKET RH
5	2	TS52	DOOR SLIDER POLY
6	2	TS53	EXPELLER DOOR GUIDE
7	1	84592	EXPELLER DOOR
8	1	TS55	DEFLECTOR ADJUSTMENT HANDLE
9	1	84598	DEFLECTOR ADJUSTMENT LINK
10	1	84594	ADJUSTABLE FLAT DEFLECTOR
11	1	TS58	DOOR INDICATOR
12	2	TS59	DEFLECTOR SIDE PIN
13	1	TS60	DEFLECTOR MID PIN
14	1	TS61	DEFLECTOR SEAL LH
15	1	TS62	MID DEFLECTOR SEAL
16	1	TS63	DEFLECTOR SEAL RH
17	2	TS64	SEAL STRAP LONG
18	1	TS65	SEAL STRAP MID
19	2	TS66	SEAL STRAP SHORT
20	2	T143	CYLINDER PIN
21	4	T144	CLIP PIN
22	1	TS69	DEFLECTOR HANDLE PIN
23	3	YPHR02005	HAIR PIN
24	1	WM378	HAIR PIN W/ LANYARD
25	2	TS307	HANDLE PIVOT
26	2	YBHH10105	BOLT HEX, 5/16 X 3/4 G5
27	4	YBHH12010	BOLT HEX, 3/8 X 1 G5
28	1	YBHH16105	BOLT HEX, 1/2 X 3 G5
29	16	YBCR10010	BOLT CARRIAGE, 5/16 X 1 G5
30	9	YBCR12010	BOLT CARRIAGE, 3/8 X 1 G5
31	7	YBCR12020	BOLT CARRIAGE, 3/8 X 1-1/4 G5
32	1	YBCR12015	BOLT CARRIAGE, 3/8 X 1-1/2 G5
33	10	YSFS12005	SCREW SOCKET HEAD, 3/8 X 1-1/4
34	16	YWFL10005	WASHER FLAT, 5/16
35	17	YWFL12005	WASHER FLAT, 3/8
36	2	YWFL16005	WASHER FLAT, 1/2
37	2	YWLO10005	WASHER LOCK, 5/16
38	31	YWLO12005	WASHER LOCK, 3/8
39	2	YNHX10005	NUT HEX, 5/16
40	31	YNHX12005	NUT HEX, 3/8
41	16	YNTL10005	NUT HEX, TOP LOCK, 5/16
42	1	YNTL16005	NUT HEX, TOP LOCK, 1/2



**FIGURE 5**  
**EXPELLER/DISCHARGE GATE/PAN**

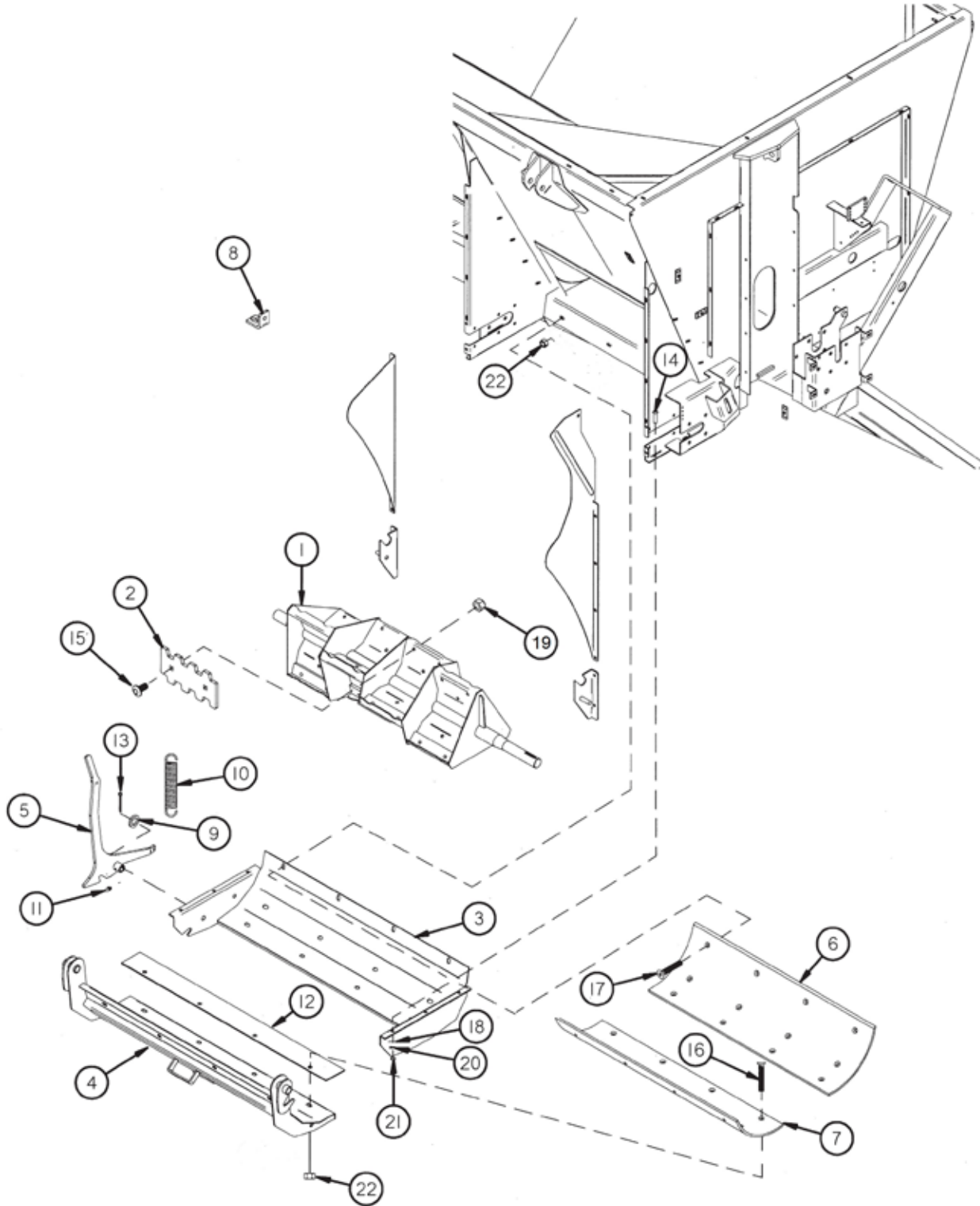

## FIGURE 5

### EXPELLER/DISCHARGE GATE/PAN

<u>ITEM</u>	<u>QTY</u>	<u>PART#</u>	<u>DESCRIPTION</u>
1	1	69616	EXPELLER
2	12	TS68	EXPELLER PADDLE
3	1	TS72	SWING AWAY PAN FRAME
4	1	TS73	SWING AWAY PAN
5	1	TS74	PAN LATCH HANDLE
6	1	TS75	EXPELLER BACK POLY
7	1	TS76	EXPELLER PAN POLY
8	1	56N146	SHIELD ANGLE
9	3	T73	SPACER
10	1	K103	SPRING
11	1	G89	GREASE ZERK
12	1	TS18	PAN RUBBER SEAL
13	1	YPCT06010	COTTER PIN, 3/16 X 1-1/4
14	6	YBCR10010	BOLT CARRIAGE, 5/16 X 1 G5
15	24	YBCR16019	BOLT CARRIAGE, 1/2 X 1-3/4 G8
16	20	YSFS16010	BOLT, FLAT SOK, 1/2 X 1-1/2
17	4	YSFS16020	BOLT, FLAT SOK, 1/2 X 1-3/4
18	6	YWFL10005	WASHER FLAT, 5/16
19	24	YNL16006	NUT HEX, TOP LOCK 1/2 G9
20	6	YWLO10005	WASHER LOCK, 5/16
21	6	YNHX10005	NUT HEX, 5/16
22	24	YNFG16003	NUT FLANGE, 1/2 GF

**FIGURE 6**  
**INPUT SHAFT/EXPELLER DRIVE**

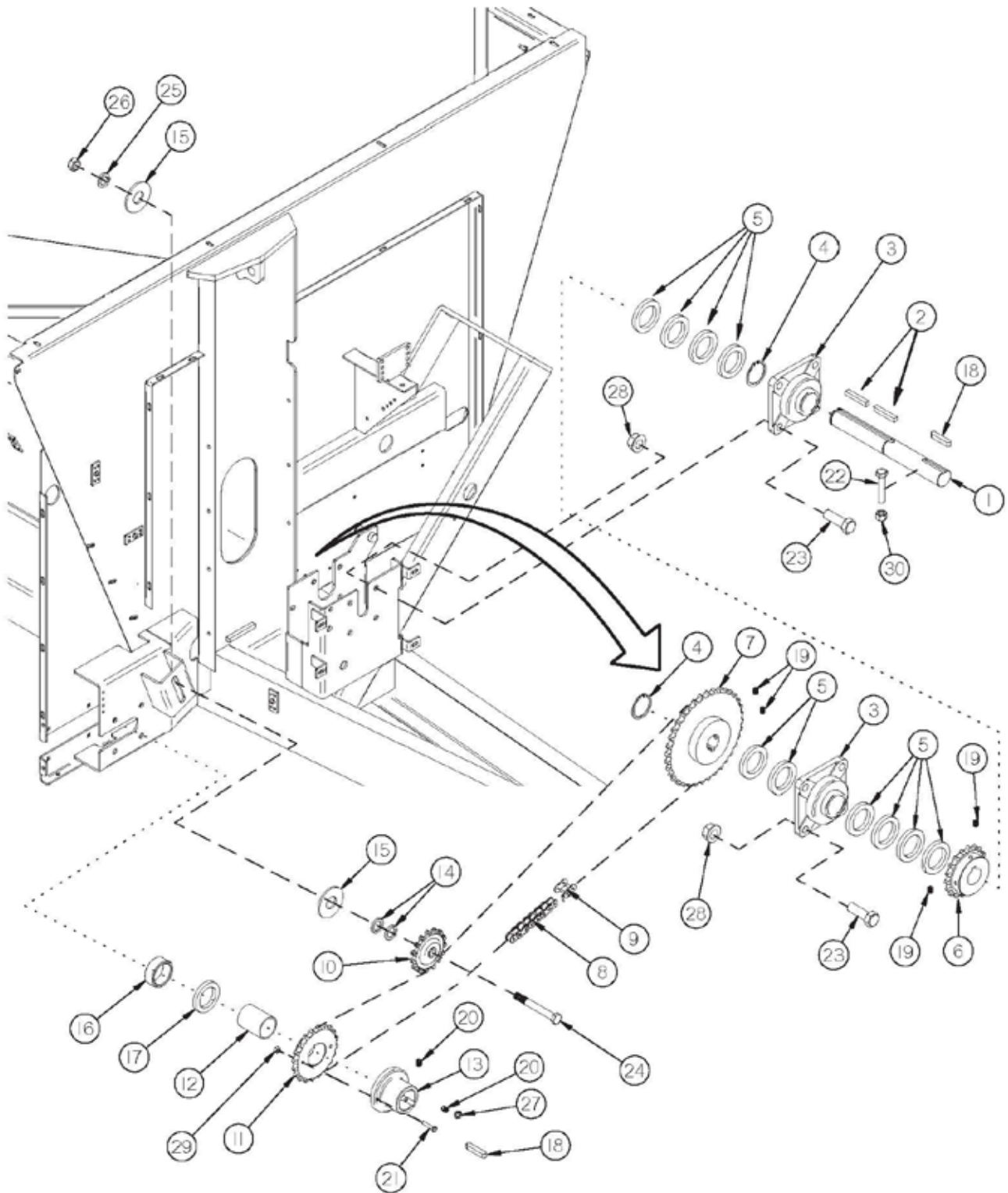

## FIGURE 6

### INPUT SHAFT/EXPELLER DRIVE

<u>ITEM</u>	<u>QTY</u>	<u>PART#</u>	<u>DESCRIPTION</u>
1	1	57392	INPUT SHAFT
2	2	68856	SQUARE KEY
3	2	12V99	BEARING
4	2	12V62	SNAP RING
5	A/R	16SV374	SPACER
*	A/R	16SV375	SPACER
*	A/R	16SV439	SPACER
*	1	33SV29	SPACER
6	1	TS35	SPROCKET/60B18 (STANDARD - 540 RPM)
*	1	TS36	SPROCKET/ASSY 13T (OPTIONAL - 540 RPM & 1000 RPM)
*	1	TS37	SPROCKET/60B15T (OPT. - 540 RPM) (STANDARD - 1000 RPM)
*	1	TS38	SPROCKET/60B20 (OPTIONAL - 540 RPM)
*	1	TS364	SPROCKET/60B16 (OPTIONAL - 1000 RPM)
7	1	TS79	SPROCKET/60B36 (STANDARD - 540 RPM)
*	1	TS80	SPROCKET/EXP DRIVE ASSY 30T (OPTIONAL - 540 RPM)
*	1	TS81	SPROCKET/60X27T (OPTIONAL - 540 RPM)
*	1	TS38	SPROCKET/60B20 (OPTIONAL - 1000 RPM)
*	1	TS318	SPROCKET/ASSY 16T (OPTIONAL - 1000 RPM)
*	1	TS365	SPROCKET/ASSY 15T (OPTIONAL - 1000 RPM)
*	1	TS366	SPROCKET/ASSY 13T (OPTIONAL - 1000 RPM)
8	1	TS82	ROLLER CHAIN #60H X 100 (540 RPM - 36T SPROCKET)
*	1	TS367	ROLLER CHAIN #60H X 97 (540 RPM - 30T SPROCKET)
*	1	TS368	ROLLER CHAIN #60H X 96 (540 RPM - 27T SPROCKET)
*	1	TS316	ROLLER CHAIN #60H X 92 (1000 RPM - 20T SPROCKET)
*	1	TS369	ROLLER CHAIN #60H X 90 (1000 RPM - 16T SPROCKET)
*	1	TS370	ROLLER CHAIN #60H X 89 (1000 RPM - 15T SPROCKET)
*	1	TS371	ROLLER CHAIN #60H X 88 (1000 RPM - 13T SPROCKET)

**\*MEANS NOT SHOWN**

**A/R MEANS AS REQUIRED**

**FIGURE 6**  
**INPUT SHAFT/EXPELLER DRIVE**

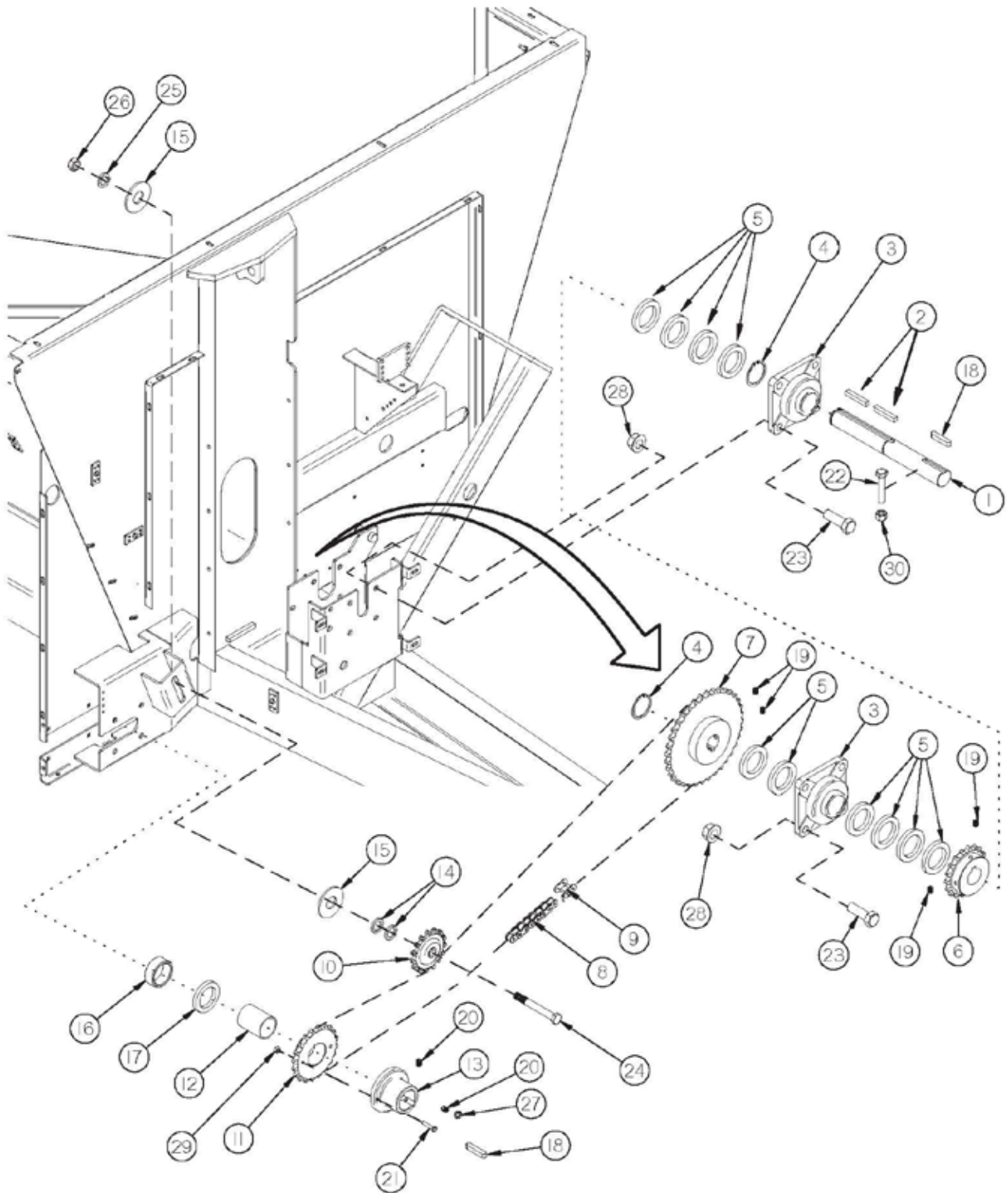

## FIGURE 6

### INPUT SHAFT/EXPELLER DRIVE

<u>ITEM</u>	<u>QTY</u>	<u>PART#</u>	<u>DESCRIPTION</u>
9	1	TS40	CONNECTOR LINK #60H
10	1	TS29	IDLER SPROCKET
11	1	TS84	SPROCKET (20T)
12	1	TS85	BRONZE BUSHING
13	1	TS86	EXPELLER SOLID SHEAR HUB
14	A/R	T73	SPACER
15	2	F129	TIGHTENER WASHER
16	1	TS329	EXPELLER DRIVE SPACER
17	A/R	S36	SHIM
*	A/R	S409	SHIM
18	2	S138	SQUARE KEY, 3/8 X 2-3/8
19	4	YSKP10010	SCREW SOCKET HEAD, 5/16 X 3/8
20	2	YSKP12010	SCREW SOCKET HEAD, 3/8 X 1/2
21	6	YBHH08027	BOLT HEX, 1/4 X 1-1/2 G8
22	1	YBHH16080	BOLT HEX, 1/2 X 2-1/2 G5
23	8	YBHH18005	BOLT HEX, 9/16 X 1-1/2 G5
24	1	YBHH20055	BOLT HEX, 5/8 X 3-1/2 G5
25	1	YWLO20005	WASHER LOCK, 5/8
26	1	YNHX20005	NUT HEX, 5/8
27	1	YNJM12005	NUT HEX, JAM, 3/8
28	8	YNSF18005	NUT, FLANGE, 9/16
29	2	YNTL08005	NUT HEX, TOP LOCK, 1/4
30	1	YNTL16005	NUT HEX, TOP LOCK, 1/2 (540 RPM PTO)

**\*MEANS NOT SHOWN**

**A/R MEANS AS REQUIRED**

# **FIGURE 7** **GUARDS/SHIELDS**

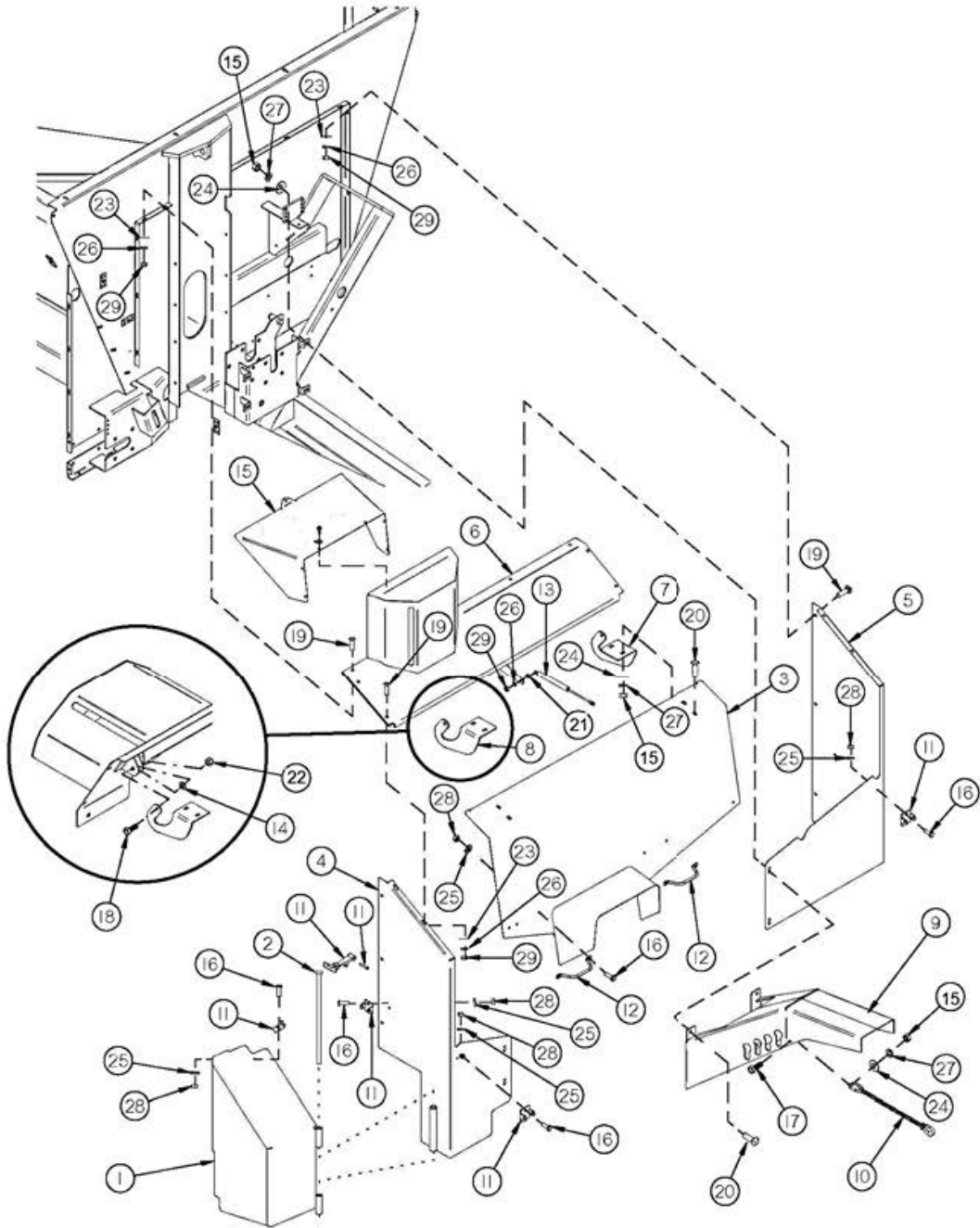



## FIGURE 7

### GUARDS/SHIELDS

<u>ITEM</u>	<u>QTY</u>	<u>PART#</u>	<u>DESCRIPTION</u>
1	1	TS87	EXPPELLER DRIVE SHIELD
2	1	TS88	EXPPELLER SHIELD HINGE
3	1	TS89	FRONT SHIELD DOOR
4	1	TS90	FRONT SHIELD RH
5	1	TS91	FRONT SHIELD LH
6	1	TS92	TOP FRONT SHIELD
7	1	TS93	FRONT SHIELD HINGE RH
8	1	TS94	FRONT SHIELD HINGE LH
9	1	TS95	HOSE HOLDER
10	1	TS130	PTO HOLDER CHAIN
11	12	8736	COMPLETE LATCH
12	2	TS96	SHIELD HANDLE
13	1	S97	GAS SPRING
14	4	TS331	SPACER
15	9	YNHX12005	NUT HEX, 3/8
16	8	YBHH08015	BOLT HEX, 1/4 X 1/2 G5
17	1	YBHH12010	BOLT HEX, 3/8 X 1 G5
18	2	YBHH12035	BOLT HEX, 3/8 X 1-1/4 G5
19	13	YBCR10030	BOLT CARRIAGE, 5/16 X 3/4 G5
20	8	YBCR12010	BOLT CARRIAGE, 3/8 X 1 G5
21	2	YNJM10005	NUT HEX, JAM, 5/16
22	2	YNTL12005	NUT HEX, TOP LOCK, 3/8
23	13	YWFL10005	WASHER FLAT, 5/16
24	9	YWFL12005	WASHER FLAT, 3/8
25	8	YWLO08005	WASHER LOCK, 1/4
26	13	YWLO10005	WASHER LOCK, 5/16
27	9	YWLO12005	WASHER LOCK, 3/8
28	8	YNHX08005	NUT HEX, 1/4
29	13	YNHX10005	NUT HEX, 5/16

# **FIGURE 8** **SPLASH GUARDS/RAILS**

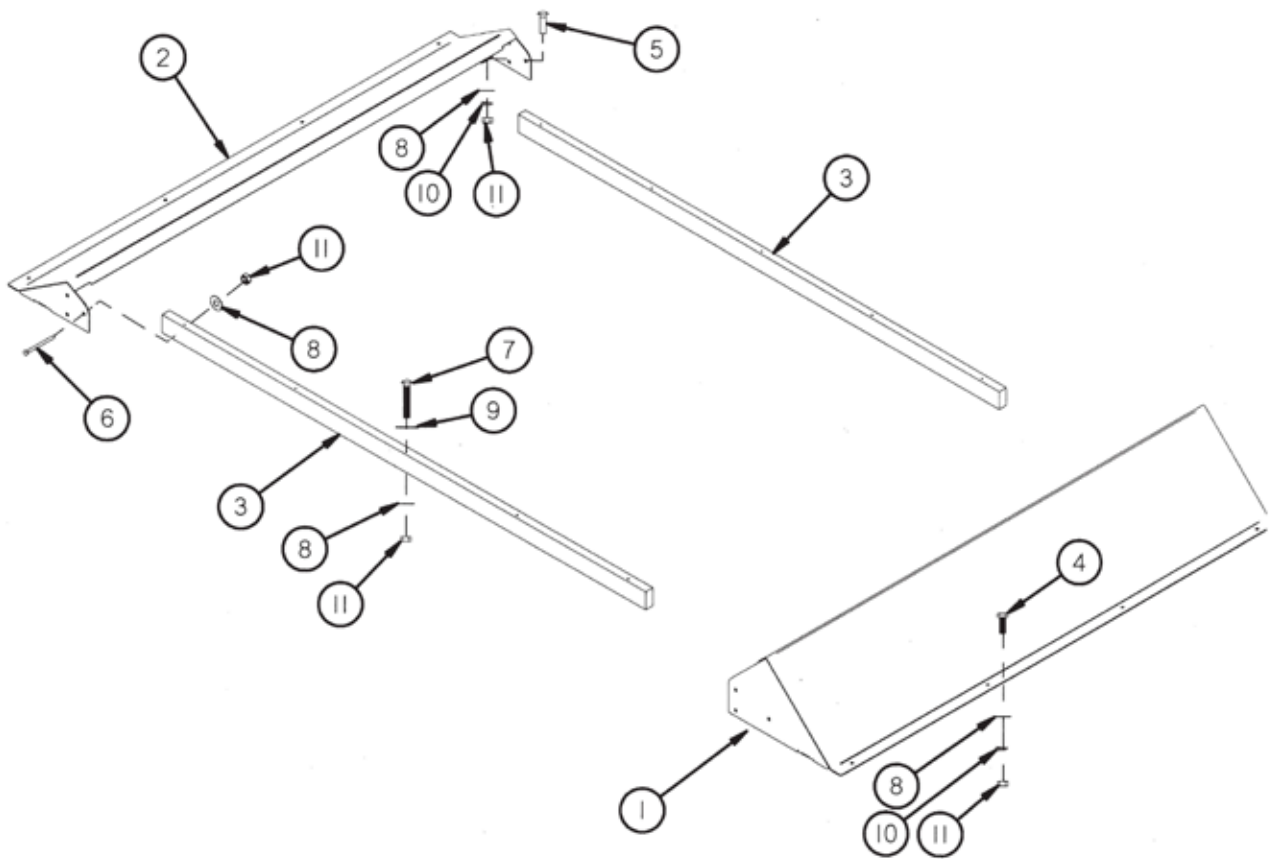

**FIGURE 8**  
**SPLASH GUARDS/RAILS**

<b><u>ITEM</u></b>	<b><u>QTY</u></b>	<b><u>PART#</u></b>	<b><u>DESCRIPTION</u></b>
1	1	TS310	FRONT SPLASH GUARD
2	1	TS311	BACK SPLASH GUARD
3	2	TS100	WOOD RAIL
4	8	YBHH12010	BOLT HEX, 3/8 X 1 G5
5	4	YBCR12010	BOLT CARRIAGE, 3/8 X 1 G5
6	12	YBCR12080	BOLT CARRIAGE, 3/8 X 3-1/4 G5
7	10	YBCR12123	BOLT CARRIAGE, 3/8 X 6-1/2 G5
8	34	YWFL12005	WASHER, FLAT, 3/8
9	10	YWFL16005	WASHER, FLAT, 1/2
10	12	YWLO12005	WASHER, LOCK, 3/8
11	34	YNHX12005	NUT HEX, 3/8

# FIGURE 9 HYDRAULICS

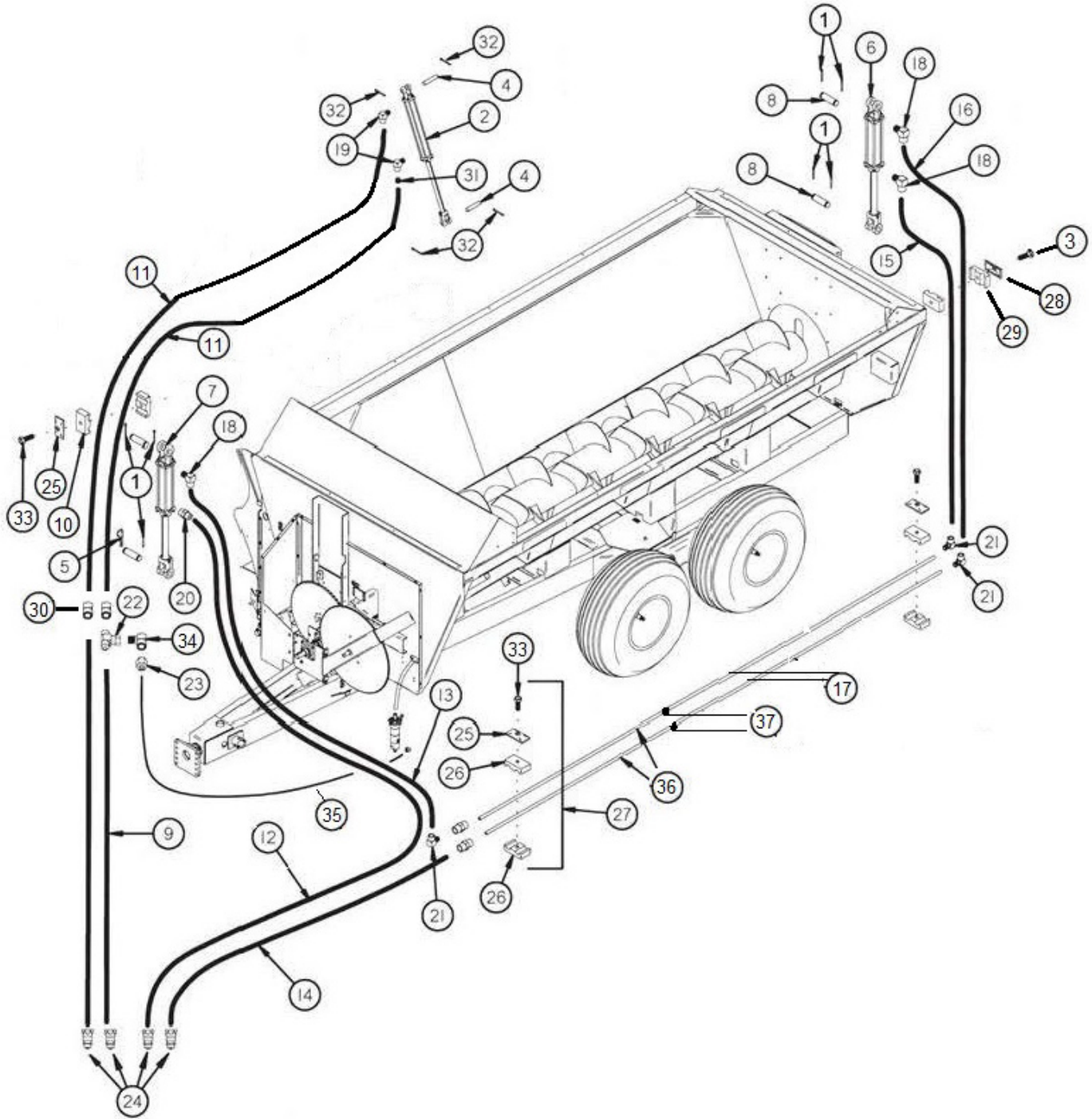

## FIGURE 9 HYDRAULICS

<u>ITEM</u>	<u>QTY</u>	<u>PART#</u>	<u>DESCRIPTION</u>
1	7	YPCT06005	COTTER PIN, 3/16 X 1-1/2
2	1	56015	CYLINDER
3	7	56569	BOLT CLAMP, 5/16 X 1-3/4 G5
4	2	LW55	CYLINDER PIN
5	1	YPHR02010	HAIR PIN
6	1	TS105	CYLINDER
7	1	TS104	CYLINDER
8	4	T143	CYLINDER PIN
9	2	85664	HYD HOSE, 6, 94
10	7	CHM278	CLAMP HALF 3/8 HOSE (SET OF 2)
11	2	85430	HYDRAULIC HOSE, 6, 125
12	1	TS111	HYDRAULIC HOSE 1/2 X 162
13	1	TS112	HYDRAULIC HOSE 1/2 X 56
14	1	TS113	HYDRAULIC HOSE 1/2 X 120
15	1	TS70	HYDRAULIC HOSE 1/2 X 42
16	1	TS71	HYDRAULIC HOSE 1/2 X 52
17	2	89070	HYDRAULIC TUBE, 1/2 X 120
18	2	TS135	STRAIGHT THREAD ELBOW FITTING
19	2	CHM164	FITTING, 90, 6JIC X 3/8NPT
20	1	TS137	-8 MALE O-RING TO -8 MALE JIC
21	3	TFM83	90 DEGREE ELBOW
22	1	CHM242	FITTING, TEE, 6JIC X 6JIC X 6JIC
23	1	73993	FITTING, ST,6JIC, 6NPTF, STL
24	4	DWM205	COUPLER MALE
25	12	56563	CLAMP TOP PLATE
26	6	TS118	LINE CLAMP BLOCK
27	3	TFM91	DOUBLE STEEL LINE CLAMP
28	5	56564	LINE CLAMP CAP
29	5	56596	CLAMP CUSHION (SET OF 2)
30	2	CHM258	UNION (6 HTX-S)
31	1	57142	IN-LINE CONNECTOR, ORIFICE, 6-XHX7-S .031
32	4	YPCT05010	COTTER PIN, 5/32 X 1-1/2
33	12	56568	BOLT HEX, 5/16 X 1-3/8 G5
34	1	58127	FITTING 6 C6X-S
35	1	86383	HYDRAULIC HOSE, 4, 78IN
36	3	89076	HYDRAULIC TUBE, 1/2 X 77
37	3	GM17	ADAPTER (8 HTX)

**FIGURE 10**  
**TANDEM AXLES 3" SPINDLE**

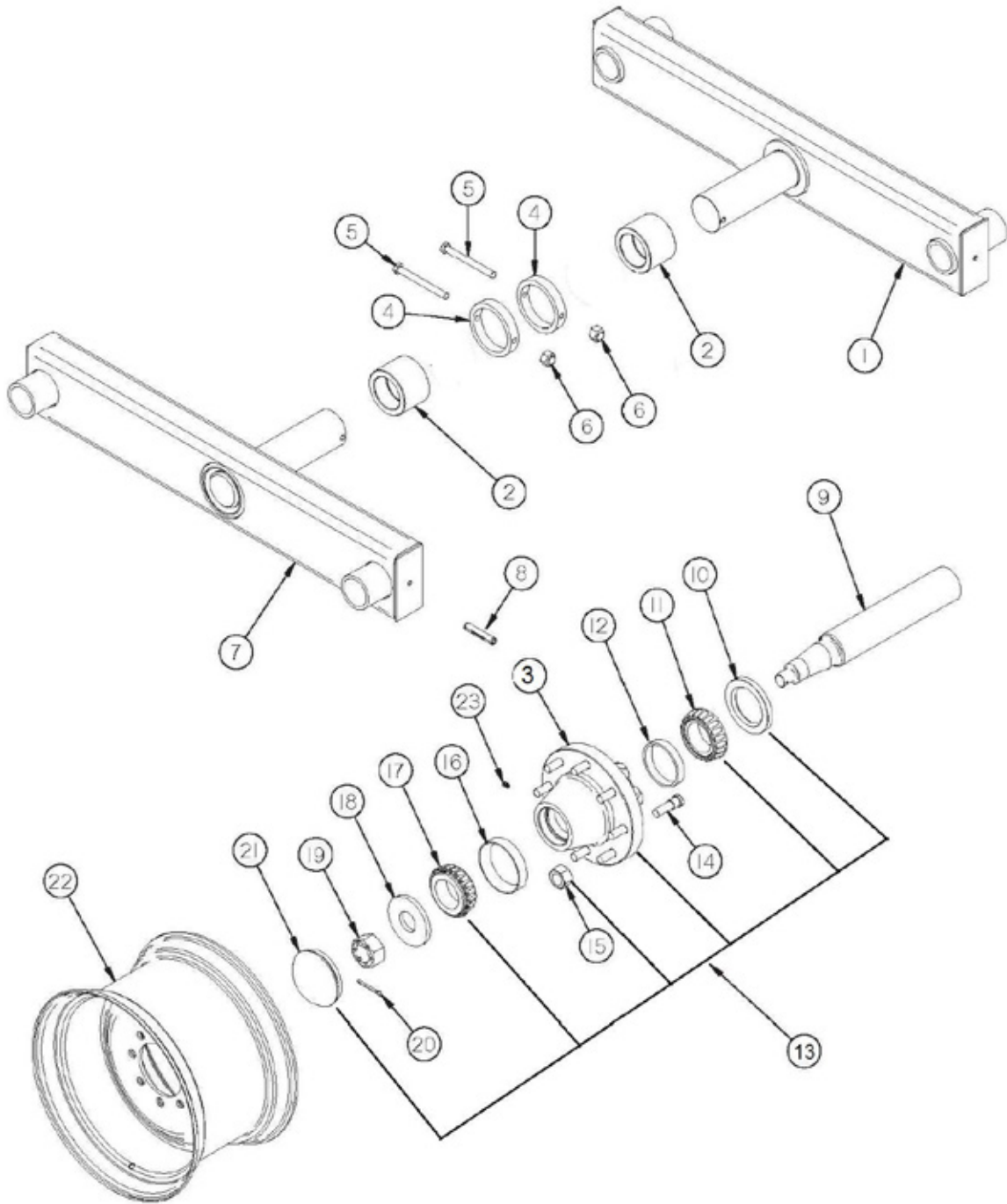

## FIGURE 10 TANDEM AXLES 3" SPINDLE

<u>ITEM</u>	<u>QTY</u>	<u>PART#</u>	<u>DESCRIPTION</u>
1	1	33SV36	MID TANDEM LH
2	4	70157	BUSHING
3	4	54596	HUB WITH RACES
4	2	16SV214	COLLAR FOR AXLE
5	2	YBHH16165	BOLT HEX, 1/2 X 6 G5
6	2	YNTL16005	NUT HEX, TOP LOCK, 1/2
7	1	33SV37	TANDEM BEAM RH
8	4	YPEX16020	EXPANSION PIN, 1/2 X 4
9	4	54577	SPINDLE
10	4	54599	SEAL
11	4	54597	INNER BEARING
12	4	54593	INNER RACE
13	4	54564	HUB - 8 BOLT COMPLETE
14	32	YBSD20010	STUD BOLT
15	32	YNWL20005	WHEEL NUT
16	4	54594	OUTER RACE
17	4	54598	OUTER BEARING
18	4	YWFL28010	WASHER FLAT, 7/8
19	4	YNSL28005	NUT HEX, SLOTTED, 7/8
20	4	YPCT05020	COTTER PIN, 5/32 X 1-3/4
21	4	B2	HUB CAP
22	4	12V36	WHEEL 14 X 16.1
*	4	33SV105	WHEEL 16 X 16.1
*	4	16SV89	WHEEL 13.5 X 22.5
23	4	54595	GREASE ZERK, 1/8

**\*MEANS NOT SHOWN**



# FIGURE 11 OILER KIT

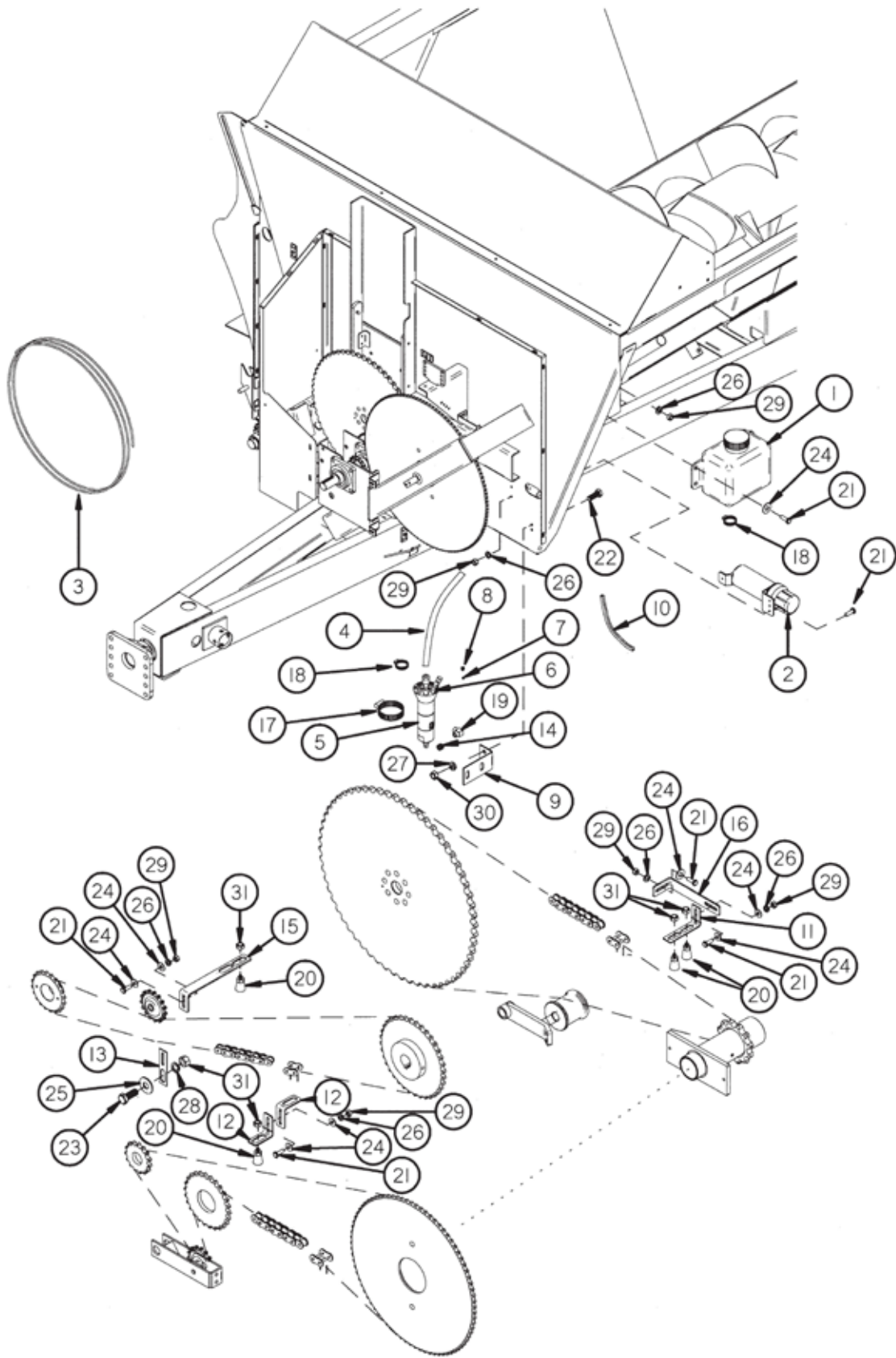

## FIGURE 11 OILER KIT

<u>ITEM</u>	<u>QTY</u>	<u>PART#</u>	<u>DESCRIPTION</u>
1	1	HGV63	RESERVOIR
2	1	S522	MANUAL HOLDER
3	1	HGV71	OIL TUBE
4	1	HGV66	FILLER HOSE
5	1	HGV82	PUMP
6	5	YNHX16005	NUT HEX, 1/2
7	2	YNHX12005	NUT HEX, 3/8
8	4	HGV84	MANIFOLD
9	1	HGV68	PUMP MOUNT BRACKET
10	1	HGV77	EDGING
11	2	HGV69	BRUSH BRACKET LONG OILER
12	2	TS98	BRUSH BRACKET SINGLE
13	1	HGV70	BRACKET MOUNT
14	1	TS198	ORIFICE .015
15	1	TS322	BRACKET
16	1	TS196	OILER HANGER
*	1	HGV62	COMPLETE OILER KIT
17	1	HGV74	HOSE CLAMP
18	2	HGV75	HOSE CLAMP
19	1	HGV65	ELBOW
20	4	HGV67	BRUSH
21	11	YBHH08100	BOLT HEX, 1/4 X 3/4 G5
22	2	YBHH12135	BOLT HEX, 3/8 X 3/4 G5
23	1	YBHH16045	BOLT HEX, 1/2 X 1-1/4 G5
24	11	YWFL08005	WASHER FLAT, 1/4
25	1	YWFL16005	WASHER FLAT, 1/2
26	11	YWLO08005	WASHER LOCK, 1/4
27	2	YWLO12005	WASHER LOCK, 3/8
28	1	YWLO16005	WASHER LOCK, 1/2
29	11	YNHX08005	NUT HEX, 1/4
30	2	YNHX12005	HEX NUT, 3/8"-16
31	5	YNHX16005	HEX NUT, 1/2"

**\*MEANS NOT SHOWN**

# FIGURE 12 FRONT GREASE LINES

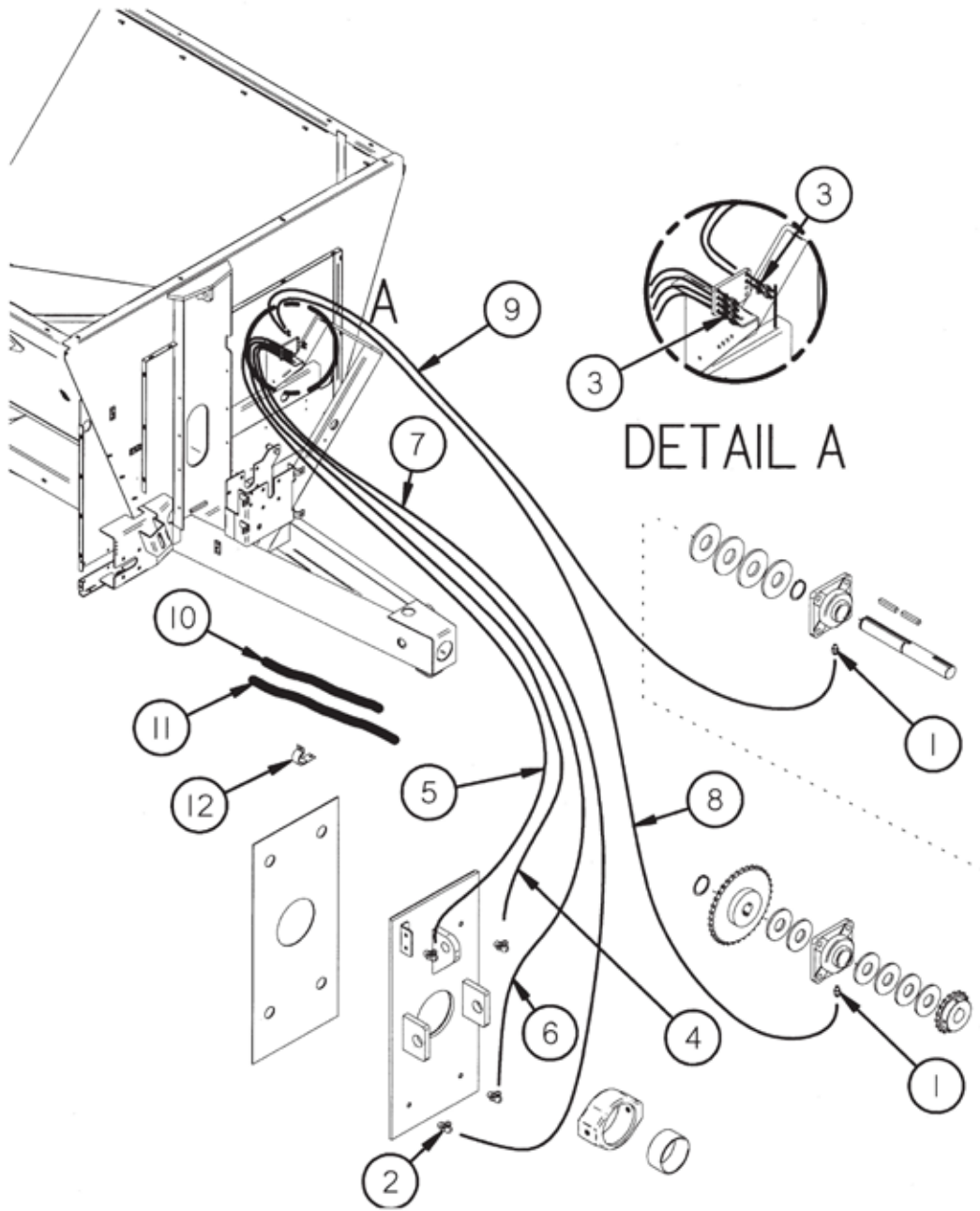

**FIGURE 12**  
**SFRONT GREASE LINES**

<b><u>ITEM</u></b>	<b><u>QTY</u></b>	<b><u>PART#</u></b>	<b><u>DESCRIPTION</u></b>
1	2	TS323	PIPE ADAPTER
2	4	GM30	GREASE LINE ADAPTER
3	6	YNJM04005	NUT JAM, 1/8 A
4	1	TS119	GREASE LINE, 23
5	1	TS120	GREASE LINE, 29.5
6	1	TS121	GREASE LINE, 38.5
7	1	TS122	GREASE LINE, 45.5
8	1	TS123	GREASE LINE, 60
9	1	TS124	GREASE LINE, 63.75
10	1	TS246	SPLIT LOOM, 3/4 X 18
11	1	TS305	SPLIT LOOM, 3/4 X 24
12	1	HGV162	RUBBER WIRE HOLDER

**FIGURE 13**  
**LIGHTING**

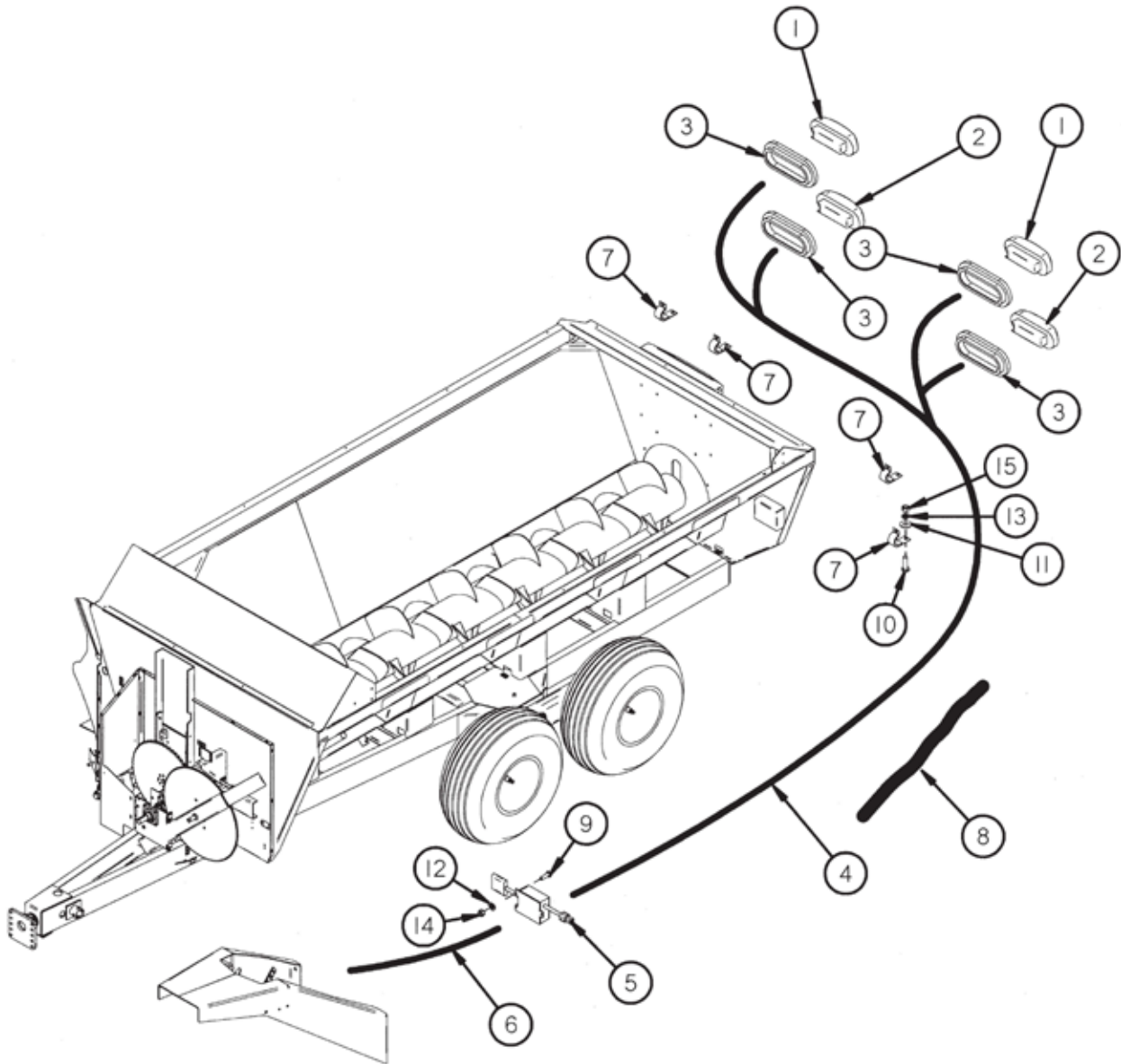

## FIGURE 13 LIGHTING

<u>ITEM</u>	<u>QTY</u>	<u>PART#</u>	<u>DESCRIPTION</u>
1	2	S309	OVAL AMBER HAZARD TAILLIGHT
2	2	S310	OVAL RED STOP/TURN TAILLIGHT
3	4	S308	OVAL LIGHT GROMMET
4	1	56N155	HARNESS - TAILLIGHT
5	1	69908	MODULE CONTROL BLINKER
6	1	TS317	HARNESS MODULE TO TRACTOR
7	4	HGV162	CUSHION WIRE CLAMP, 1/2
8	1	TS129	SPIRAL WRAP, 30
9	3	YSPP64010	PAN HEAD PHILLIPS, MACHINE SCREW, #10 X 1
10	4	YBHH10105	BOLT HEX, 5/16 X 3/4 G5
11	4	YWFL10005	WASHER FLAT, 5/16
12	3	YWLO08005	WASHER LOCK, 1/4
13	4	YWLO10005	WASHER LOCK, 5/16
14	3	YNHX64005	NUT HEX, #10-32
15	4	YNHX10005	NUT HEX, 5/16

**FIGURE 14**  
**AUGER**

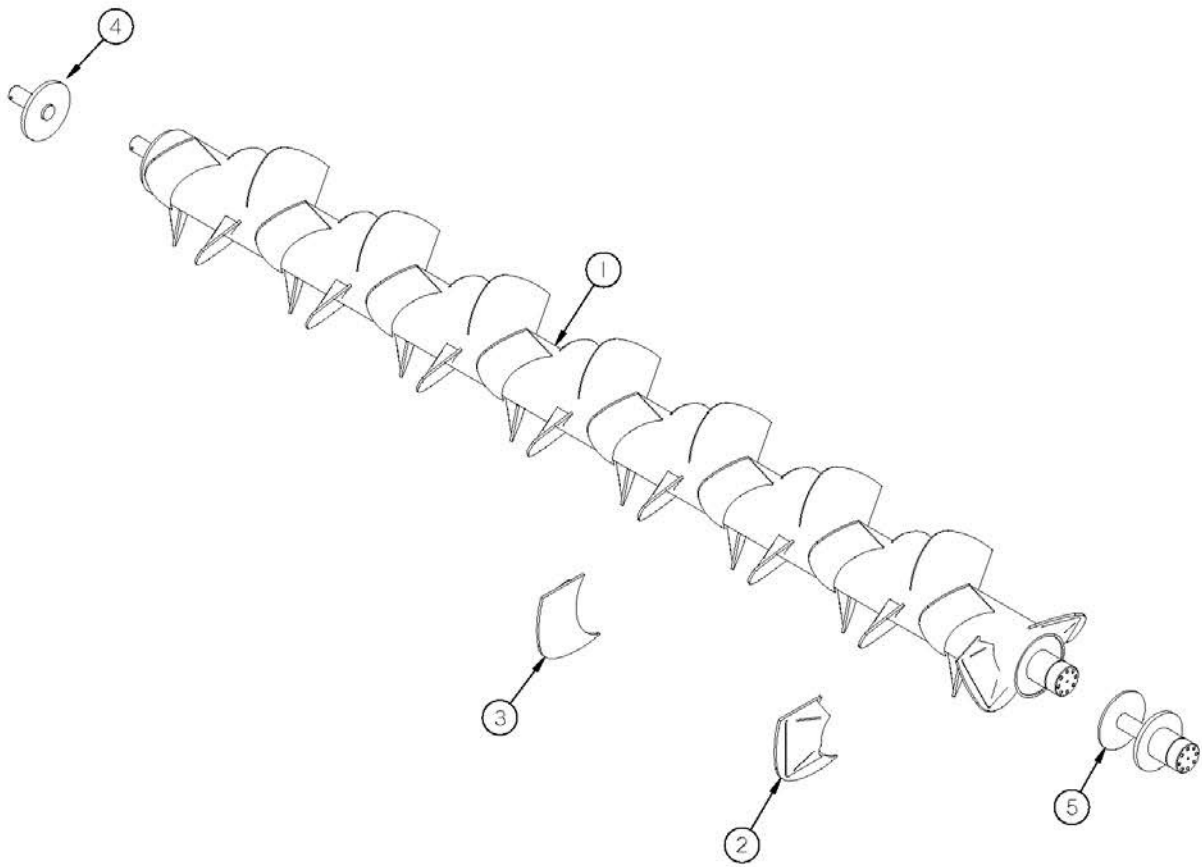

# **FIGURE 14**

## **AUGER**

<b><u>ITEM</u></b>	<b><u>QTY</u></b>	<b><u>PART#</u></b>	<b><u>DESCRIPTION</u></b>
1	1	TS1	AUGER
2	2	TS125	FRONT AUGER PADDLE
3	37	TS126	BACK AUGER PADDLE
4	1	TS127	AUGER REAR
5	1	TS128	AUGER INPUT



# **FIGURE 15** **AUGER FRONT/REAR HYDRAULIC CYLINDER**

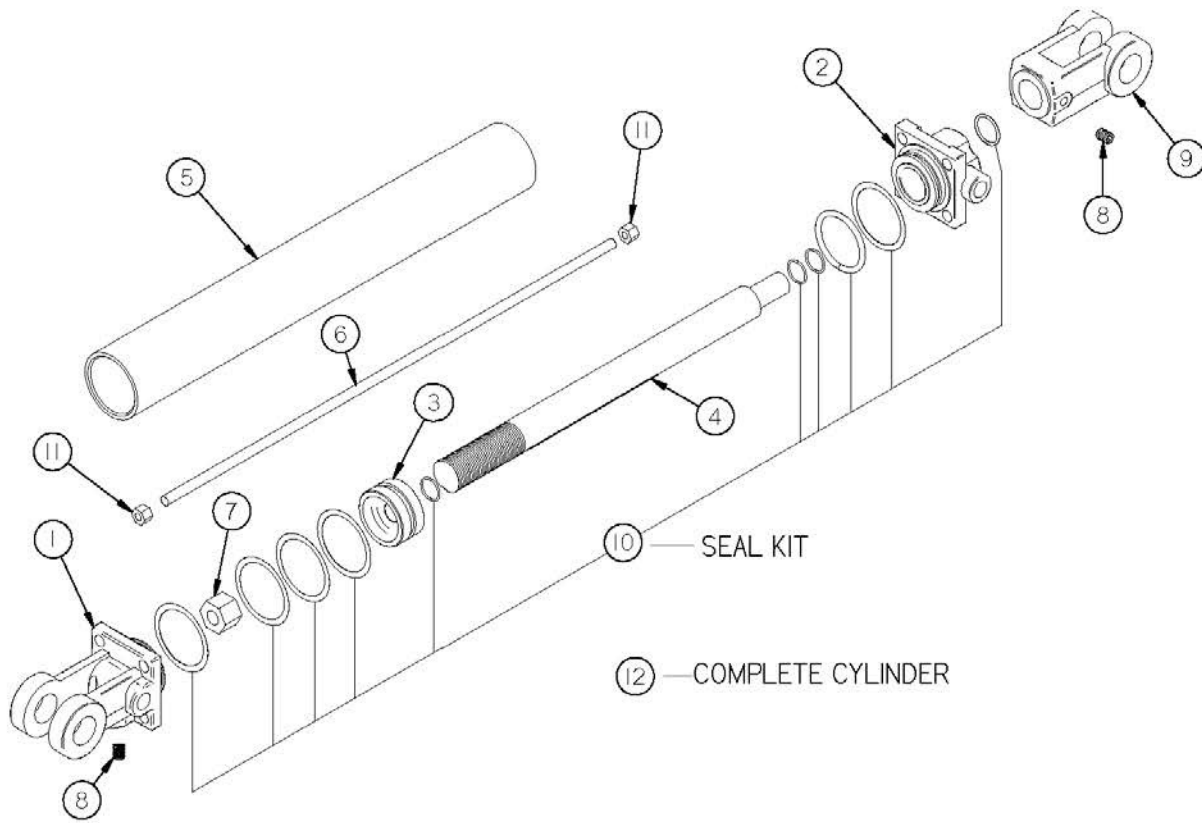
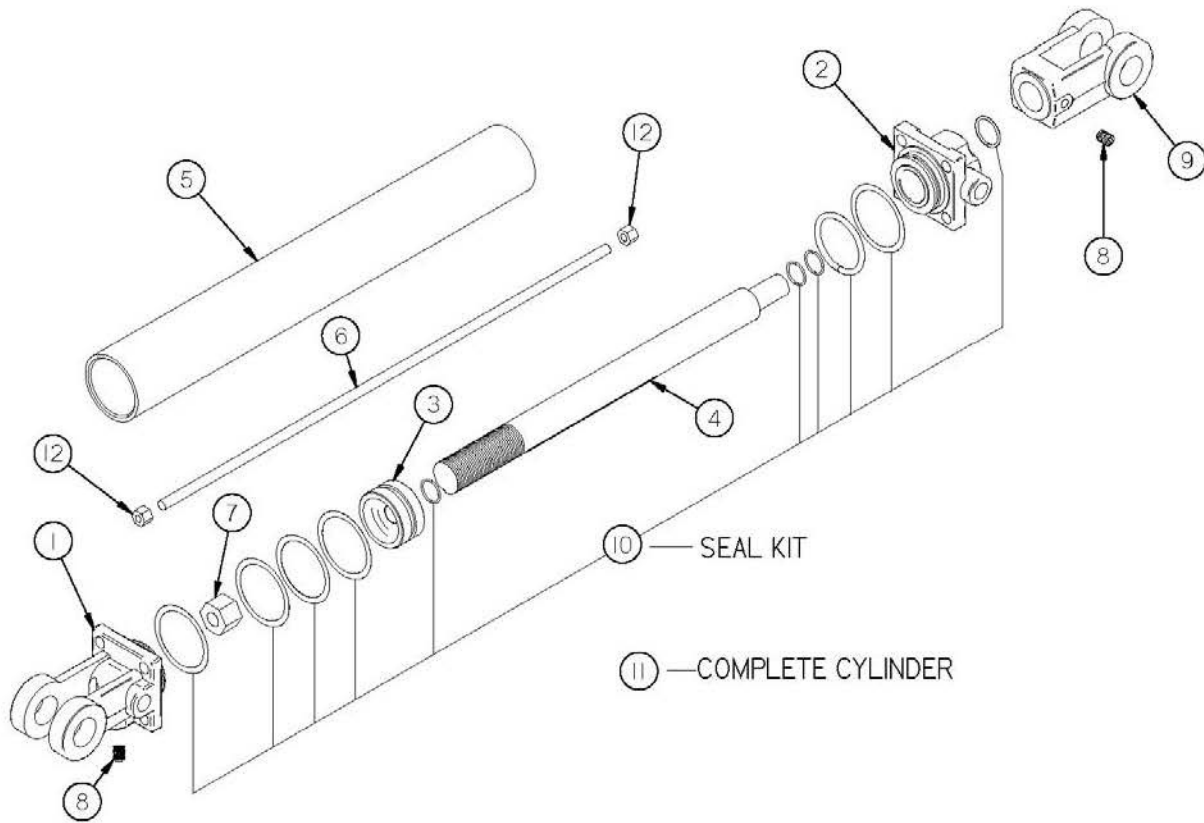

**FIGURE 15**  
**AUGER FRONT/REAR HYDRAULIC CYLINDER**

<u>ITEM</u>	<u>QTY</u>	<u>PART# 3" BORE</u>	<u>PART# 3-1/4" BORE</u>	<u>DESCRIPTION</u>
1	1	TS160	TS176	BASE
2	1	TS158	TS174	HEAD
3	1	TS159	TS175	PISTON NUT
4	1	TS156	TS172	ROD
5	1	TS157	TS173	TUBE
6	4	TS153	TS171	TIE ROD
7	1	TS145	TS166	PISTON NUT
8	1	TS152	"	PLUG
9	1	TS155	"	CLEVIS ASSEMBLY
10	1	TS163	TS177	SEAL KIT
11	8	TS144	TS165	TIE ROD NUT
12	1	TS104	_____	CYLINDER
*	1	_____	TS105	CYLINDER

**\*MEANS NOT SHOWN**

**FIGURE 16**  
**EXPELLER DOOR HYDRAULIC CYLINDER 2" x 16"**

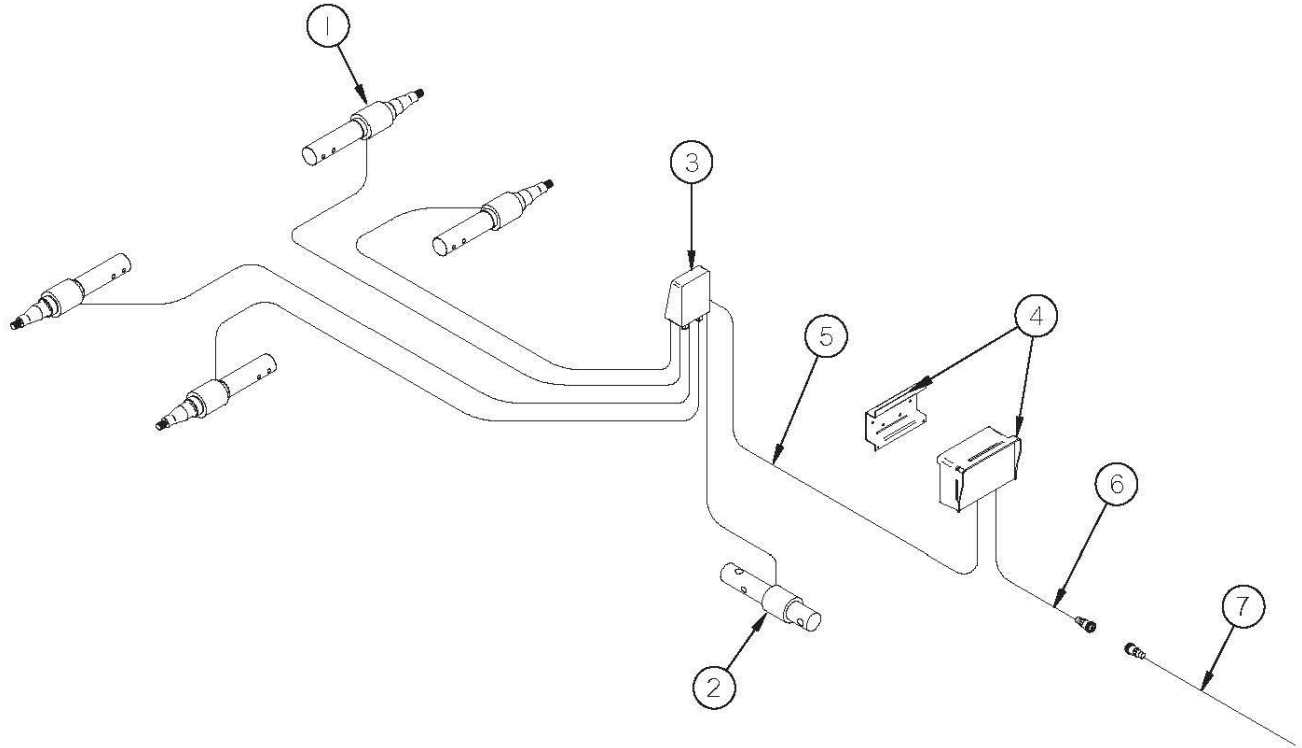

**FIGURE 16**  
**EXPPELLER DOOR HYDRAULIC CYLINDER 2" x 16"**

<b><u>ITEM</u></b>	<b><u>QTY</u></b>	<b><u>PART#</u></b>	<b><u>DESCRIPTION</u></b>
1	1	23N142A	CLEVIS CAP
2	1	23N143	ROD CAP
*	1	56174	ROD CAP
3	1	23N144	PISTON
*	1	56180	PISTON FOR 2 CYLINDER
4	1	23N145A	ROD
5	1	23N146	CYLINDER TUBE
6	4	23N147	SHAFT, RND, 0.33 X 20.19
7	1	23N148	PISTON NUT
8	2	23N149	PLUG
9	1	23N150A	ROD CLEVIS
10	1	23N151	SEAL KIT
*	1	56187	SEAL KIT FOR 2 CYLINDER
11	1	23N111A	HYDRAULIC CYLINDER 2 X 16
*	1	56015	HYDRAULIC CYLINDER 2 X 16
12	8	YNHX12005	NUT HEX, 3/8

**\*MEANS NOT SHOWN**

**FIGURE 17**  
**SCALE**



## **FIGURE 17** **SCALE**

<b><u>ITEM</u></b>	<b><u>QTY</u></b>	<b><u>PART#</u></b>	<b><u>DESCRIPTION</u></b>
1	4	TS333	SPINDLE LOAD CELL
2	1	GM403	HITCH LOAD CELL
3	1	TS83	JUNCTION BOX
4	1	GM408	SCALE HANGER BRACKET
*	1	TS337	SCALE DISPLAY W/GPS
5	1	TS338	JUNCTION BOX CORD
6	1	TS385	CABLE POWER 10FT, 4 WIRE
7	1	16SV269	TRACTOR CONTROL CORD

**\*MEANS NOT SHOWN**

**FIGURE 18**  
**OPTIONAL PTO (540 RPM)**

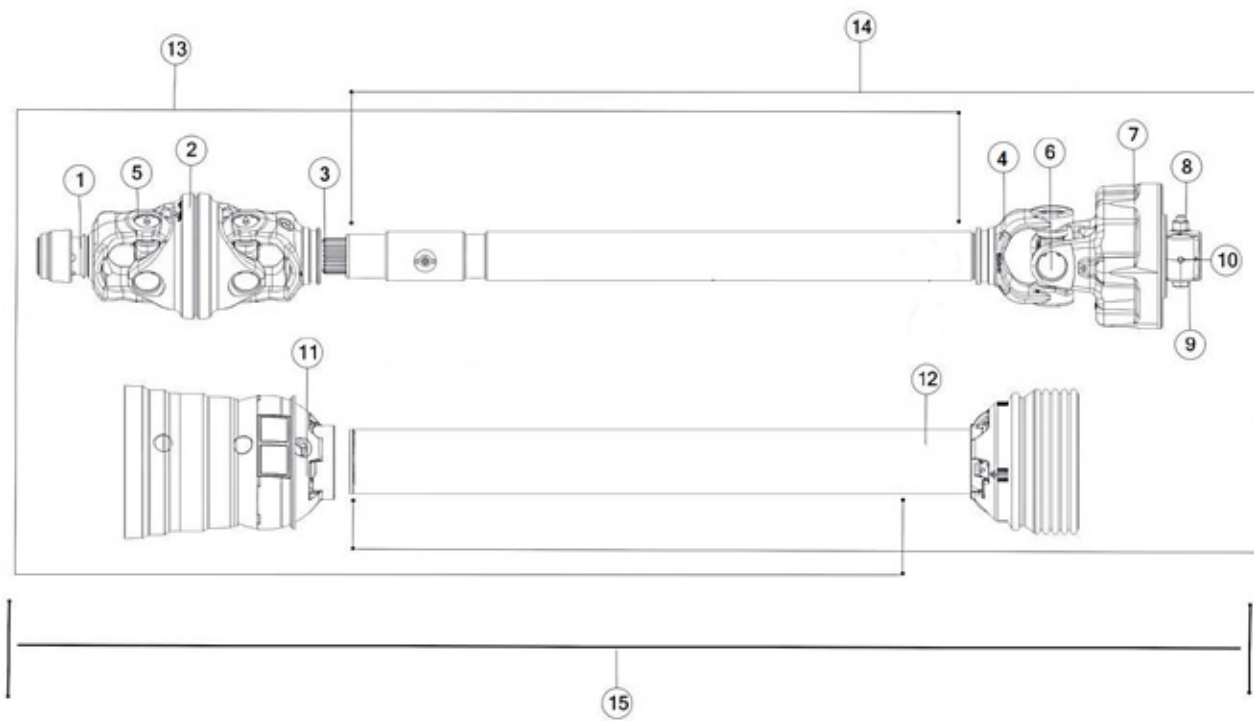

## FIGURE 18

### OPTIONAL PTO (540 RPM)

<u>ITEM</u>	<u>QTY</u>	<u>PART#</u>	<u>DESCRIPTION</u>
1	1	56655	PTO, YOKE, TUBE & SLIP SLEEVE, 540 RPM
2	1	56509	CENTER HOUSING PTO PART
3	1	57971	YOKE & SHAFT
4	1	70598	PTO YOKE TUBE & SLIP SLEEVE
5	1	56656	CROSS KIT
6	1	63405	CROSS KIT, 55E
7	1	70565	PTO, CLUTCH 55 AUTO
8	1	YNFG16005	NUT HEX, FLANGE, 1/2
9	1	YBFB16040	BOLT FLANGE, 1/2 X 3 G8
10	1	YSKP12030	SET SCREW, SOCKET HEAD
11	1	57973	OUTER GUARD
12	1	70597	OUTER GUARD
13	1	57967	JOINT & SHAFT HALF ASM. W/ GUARD
14	1	70591	PTO, JOINT & TUBE HALF, GUARDED, 540 RPM
15	1	70647	PTO, 540 RPM
*	1	57972	GUARD REPAIR KIT
*	1	16SV274	SAFETY SLIDE LOCK REPAIR KIT
*	1	S402	ADMA SAFETY MANUAL

**\*MEANS NOT SHOWN**



**FIGURE 19**  
**PTO (1000 RPM)**

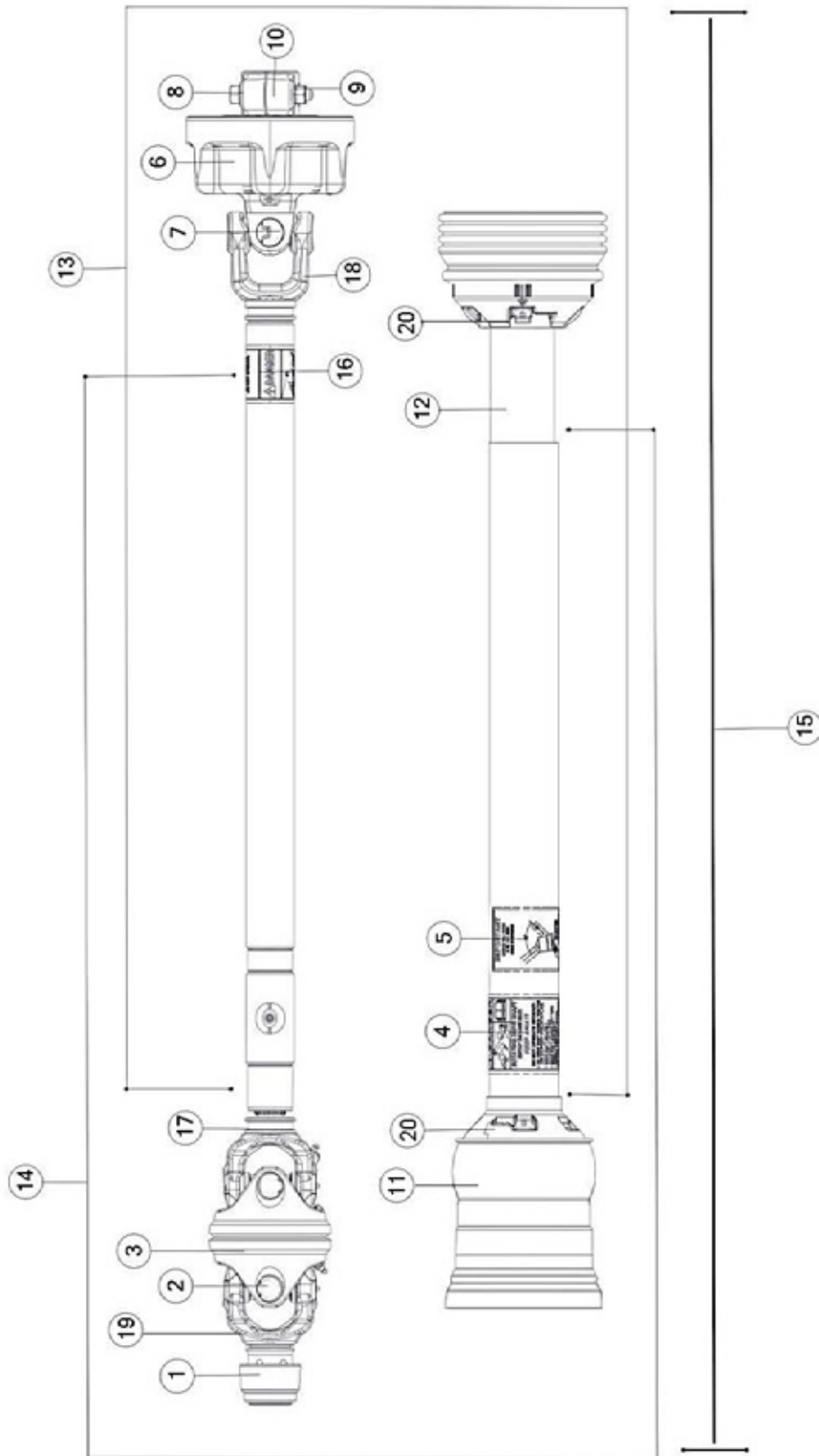

## **FIGURE 19**

### **PTO (1000 RPM)**

<b><u>ITEM</u></b>	<b><u>QTY</u></b>	<b><u>PART#</u></b>	<b><u>DESCRIPTION</u></b>
1	1	16SV274	SAFETY SLIDE LOCK REPAIR KIT
2	1	63784	CROSS KIT, AB6/AW22/480 EBL
3	1	TS180	CENTER HOUSING
4	1	1494L	DECAL-DANGER ROTATING DRIVE
5	1	16SV286	SAFETY SIGN (C.V INSTRUCTIONAL DECAL)
6	1	70563	PTO CLUTCH
7	1	61370	CROSS KIT
8	1	YBFB16040	BOLT FLANGE, 1/2 X 3 G8
9	1	YNFG16005	NUT HEXFLANGED, 1/2
10	1	YSKP12030	SCREW SOCKET KNURLED, 3/8 X 3/8
11	1	TS182	OUTER GUARD
12	1	70585	INNER GUARD
13	1	70581	JOINT & TUBE HALF GUARDED, 1000 RPM
14	1	63790	JOINT & SHAFT HALF GUARDED
15	1	70329	PTO 1000 RPM
16	1	16SV388	SAFETY SIGN
17	1	70583	YOKE & SHAFT, 1000 RPM
18	1	70586	YOKE TUBE & SLIP SLEEVE, 1000 RPM
19	1	63389	YOKE, 4 80 WWCV, AUTO-LOC
20	1	16SV383	GUARD REPAIR KIT
*	1	S402	ADMA SAFETY MANUAL

**\*MEANS NOT SHOWN**

# **FIGURE 20** **OPTIONAL TANDEM AXLES**

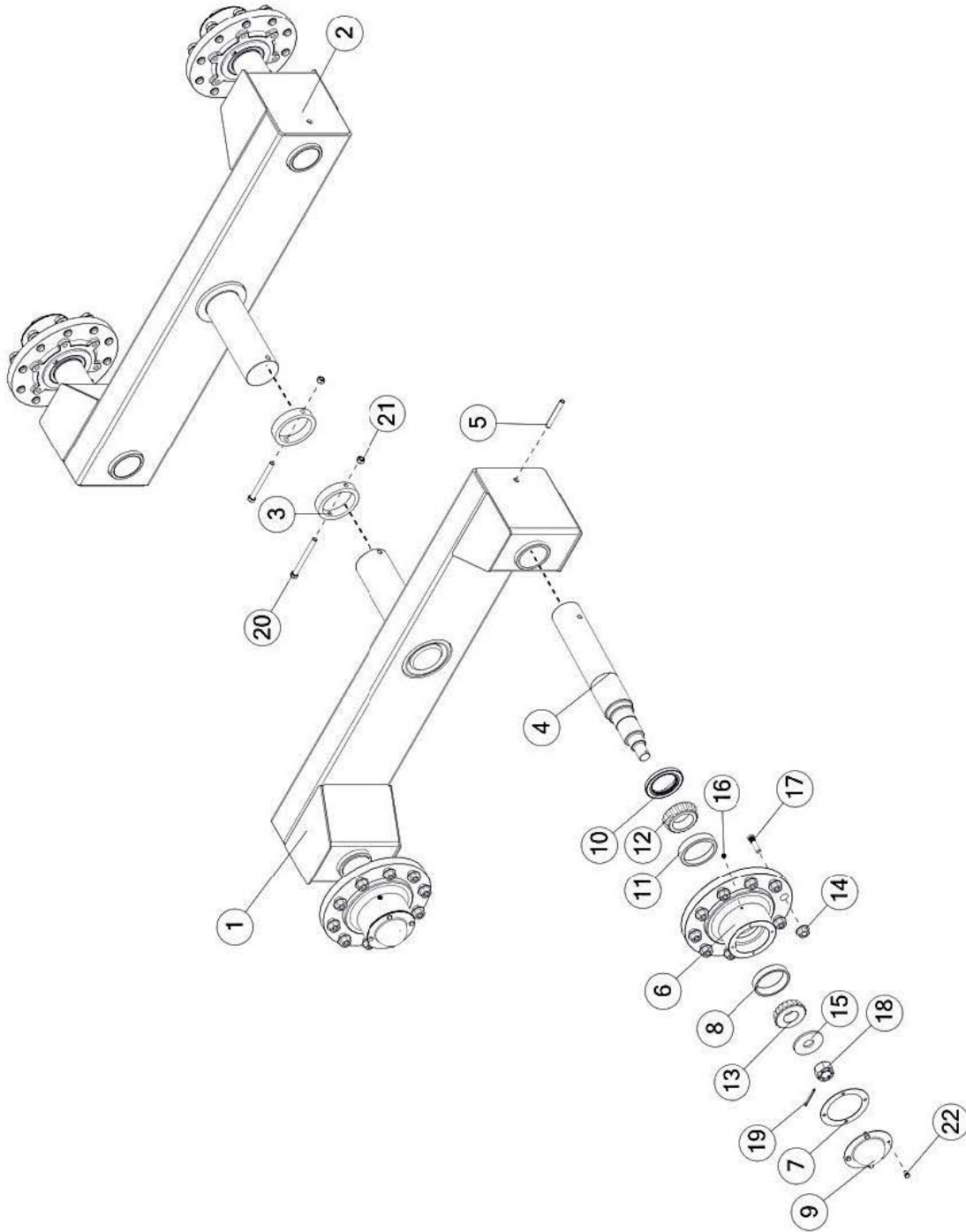

## FIGURE 20

### OPTIONAL TANDEM AXLES

<u>ITEM</u>	<u>QTY</u>	<u>PART#</u>	<u>DESCRIPTION</u>
1	1	75458	TANDEM AXLE LH
2	1	75451	TANDEM AXLE RH
3	2	16SV214	AXLE MOUNT COLLAR
4	4	TS46	TANDEM SPINDLE
5	4	YPEX16020	EXPANSION PIN
6	4	54493	HUB CASTING
7	4	56234	HUB CAP GASKET
8	4	60N10	OUTER RACE
9	4	60N11	HUB CAP
10	4	60N5	GREASE SEAL
11	4	60N6	INNER RACE
12	4	60N7	TAPERED ROLLER BEARING
13	4	60N9	TAPERED ROLLER BEARING
14	40	YNWL24005	NUT FLANGE, 3/4 G8
15	4	60N2	SPINDLE WASHER
16	4	BFR28	GREASE ZERK, 1/8
17	40	YBSD24010	BOLT STUD, 3/4 X 2-3/4 X 3/4 G8
18	4	YNCA36005	NUT CASTLE, 1-1/4
19	4	YPCT07005	COTTER PIN, 7/32 X 2
20	2	YBHH16160	BOLT HEX, 1/2 X 5-1/2 G5
21	2	YNTL16005	NUT HEX, 1/2
22	16	YBHH10020	BOLT HEX, 5/16 X 1/2 G5

# FIGURE 21 OPTIONAL TIRE & WHEEL

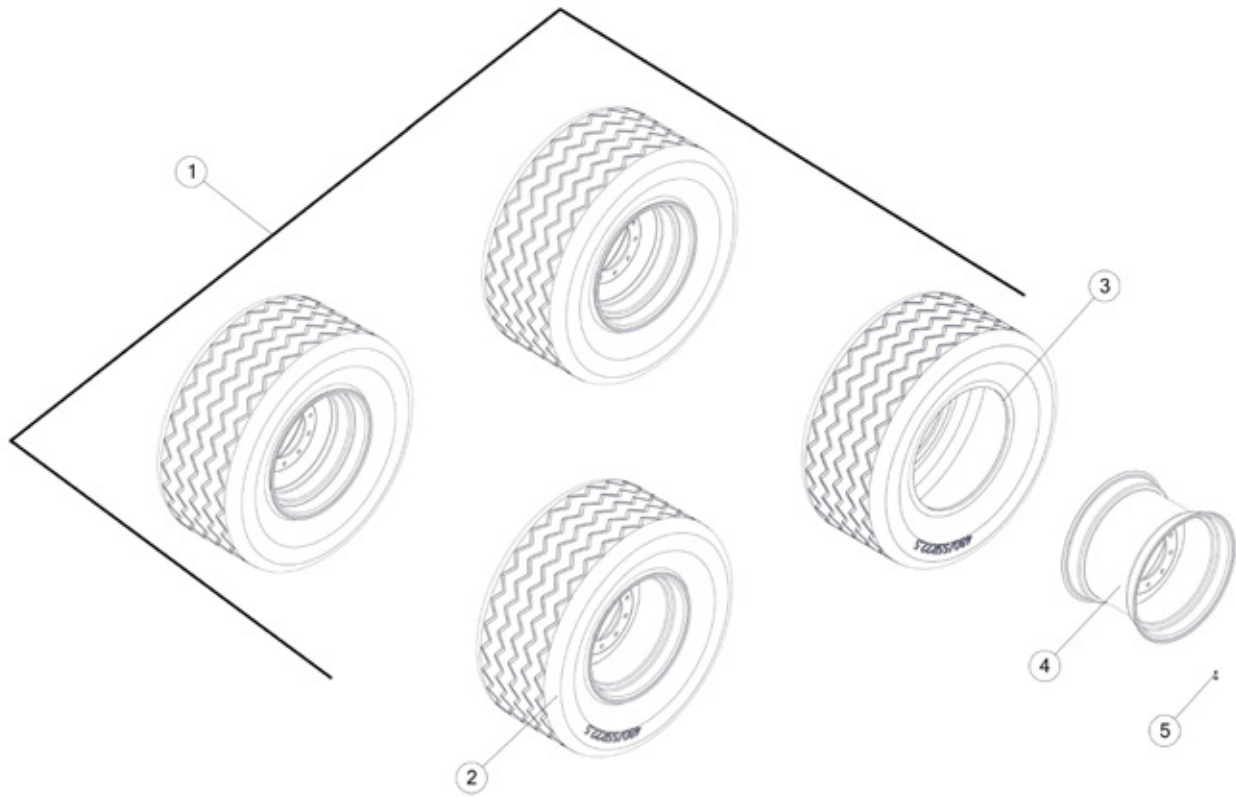

**FIGURE 21**  
**OPTIONAL TIRE & WHEEL**

<b><u>ITEM</u></b>	<b><u>QTY</u></b>	<b><u>PART#</u></b>	<b><u>DESCRIPTION</u></b>
1	1	TWP480	480/55R TIRE X 22.5 X AG16, 10 BLT WHL
2	4	77559	480/55 TIRE, 22.5 X AG16, 10 BLT WHL
3	4	77558	TIRE 480/55R22.5
4	4	77546	WHEEL 22.5 X AG16, 10 HOLE (OFF-WHITE)
5	4	72436	VALVE STEM, 1-1/2" RUBBER

**FIGURE 22**  
**DISCHARGE DEFLECTOR HYDRAULIC OPTIONAL**

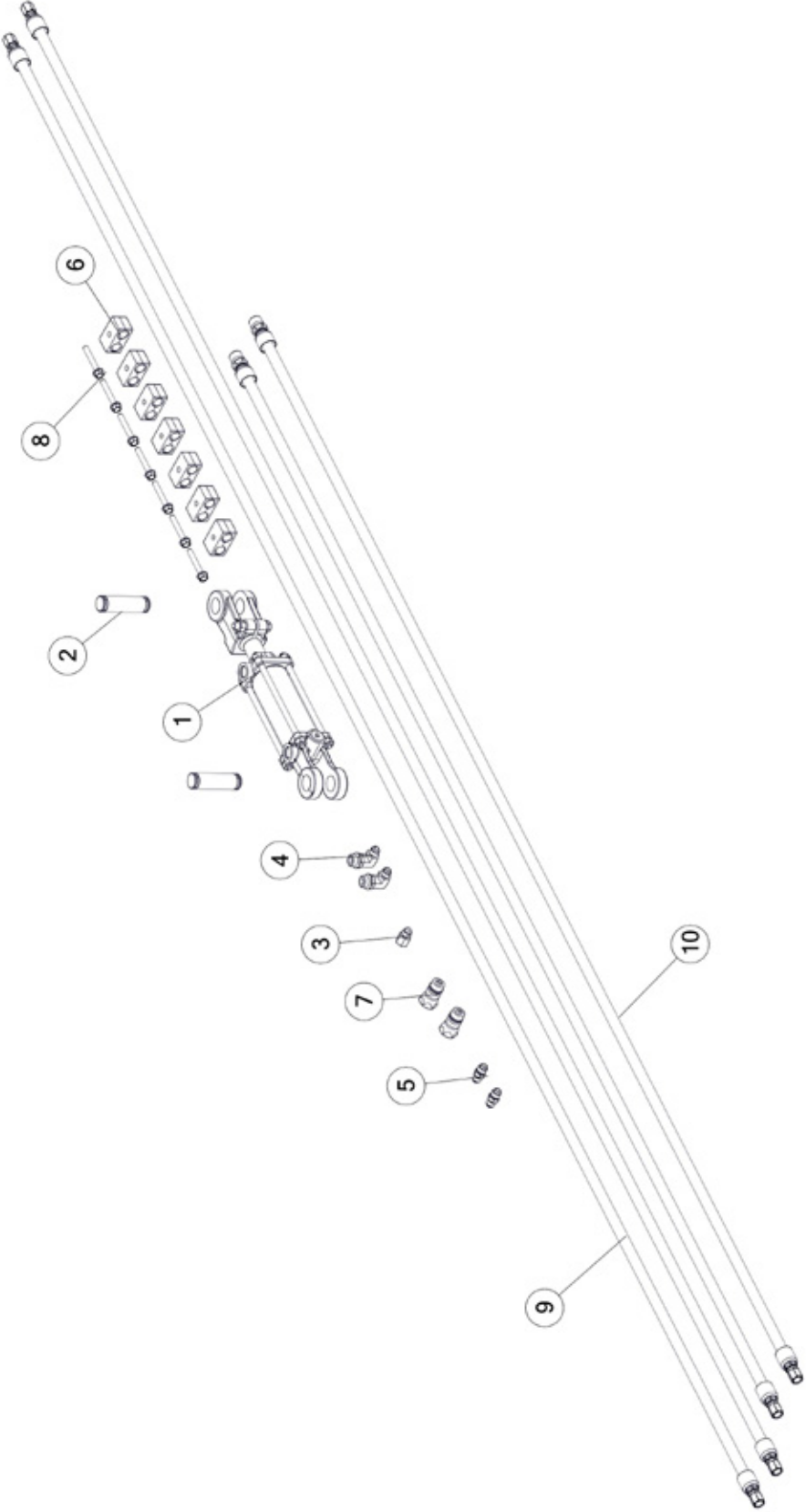

## FIGURE 22

### DISCHARGE DEFLECTOR HYDRAULIC OPTIONAL

<u>ITEM</u>	<u>QTY</u>	<u>PART#</u>	<u>DESCRIPTION</u>
1	1	70797	CYLINDER, HYDRAULIC, 10.2 X 14.2
*	1	72161	SEAL KIT
2	2	72160	2 CYL TIE ROD
3	1	58142	IN-LINE CONNECTOR, ORIFICE, 6-XHX7-S .031
4	2	CHM206	06 90 DEG TO 3/4-16 ORB FITTING
5	2	CHM258	FITTING ST, 6 JIC, 6 JIC
6	7	CHM278	3/8 TWO LINE CLAMP BLOCK
7	2	DWM205	VMI - MALE QUICK COUPLER S71-4P SAFEWAY HYD TIP
8	7	YBFB10225	BOLT FLANGE, 5/16 X 2-1/4 G5
9	2	85446	HYDRAULIC HOSE, 6, 127 IN
10	2	85664	HYDRAULIC HOSE, 6, 94 IN

**\*MEANS NOT SHOWN**



**FIGURE 23**  
**ELECTRIC VALVE FOR DISCHARGE DEFLECTOR HYD.CYL.**

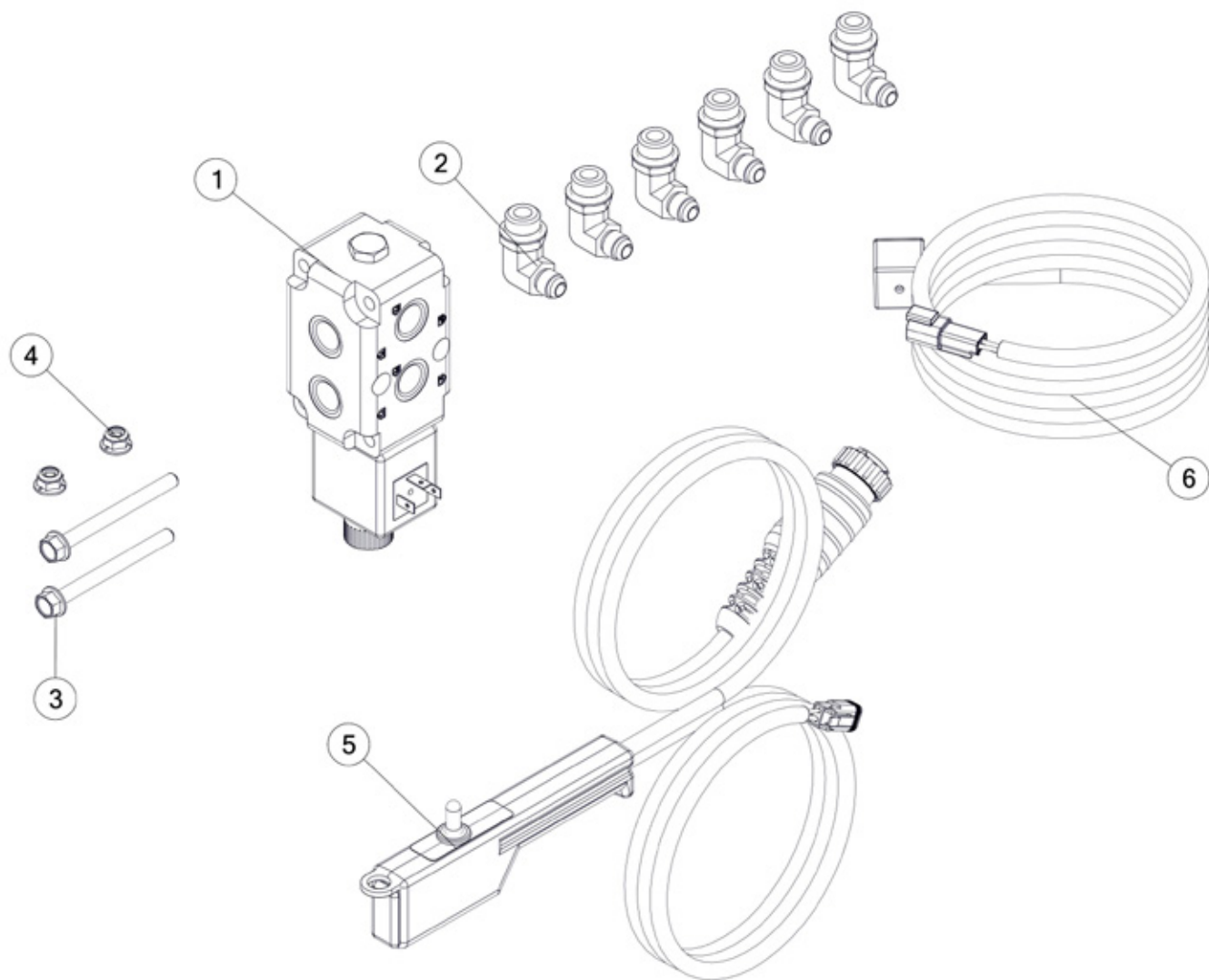

## **FIGURE 23**

### **ELECTRIC VALVE FOR DISCHARGE DEFLECTOR HYD.CYL.**

<b><u>ITEM</u></b>	<b><u>QTY</u></b>	<b><u>PART#</u></b>	<b><u>DESCRIPTION</u></b>
1	1	FR81	SOLENOID SELECTOR VALVE
2	6	CHM206	06 90 DEG TO 3/4-16 ORB FITTING
3	2	YBFB10350	BOLT FLANGE, 5/16 X 3-1/2 G8
4	2	YNFG10005	NUT FLANGE, 5/16 GF
5	1	85397	HAND CONTROLLER, (ON)-OFF
6	1	56138	10' DIN TO 2 PIN FEMALE DEUTSCH CORD



# CHANGE NOTES

1. Replace TS54 with 84592, TS56 with 84598 and TS57 with 84594 on Fig 4.
2. Replace TS110 with 85664, TS109 with 85430, TS136 with CHM232, TFM38 with TFM83, TS139 with CHM242, TS299 with 73993, GM69 with 56564, GM70 with 56596, TS197 with 57142. Removed TS107, TS117, GM9. Added 58127, CHM278, 56563 and CHM258. On Fig 9
3. Added figure 22 and 23 to the book.
4. Figure 10 - Item 5 YBHH16155 replaced with YBHH16165 and Item 18 YWFL28005 replaced with YWFL28010.
5. Figure 9 - Change Image and items

**H&S MFG. CO.**

products approved

for the

**FEMA**

**SEAL OF QUALITY**

