

H&S PARTS BOOK

TS5226 SPREADER

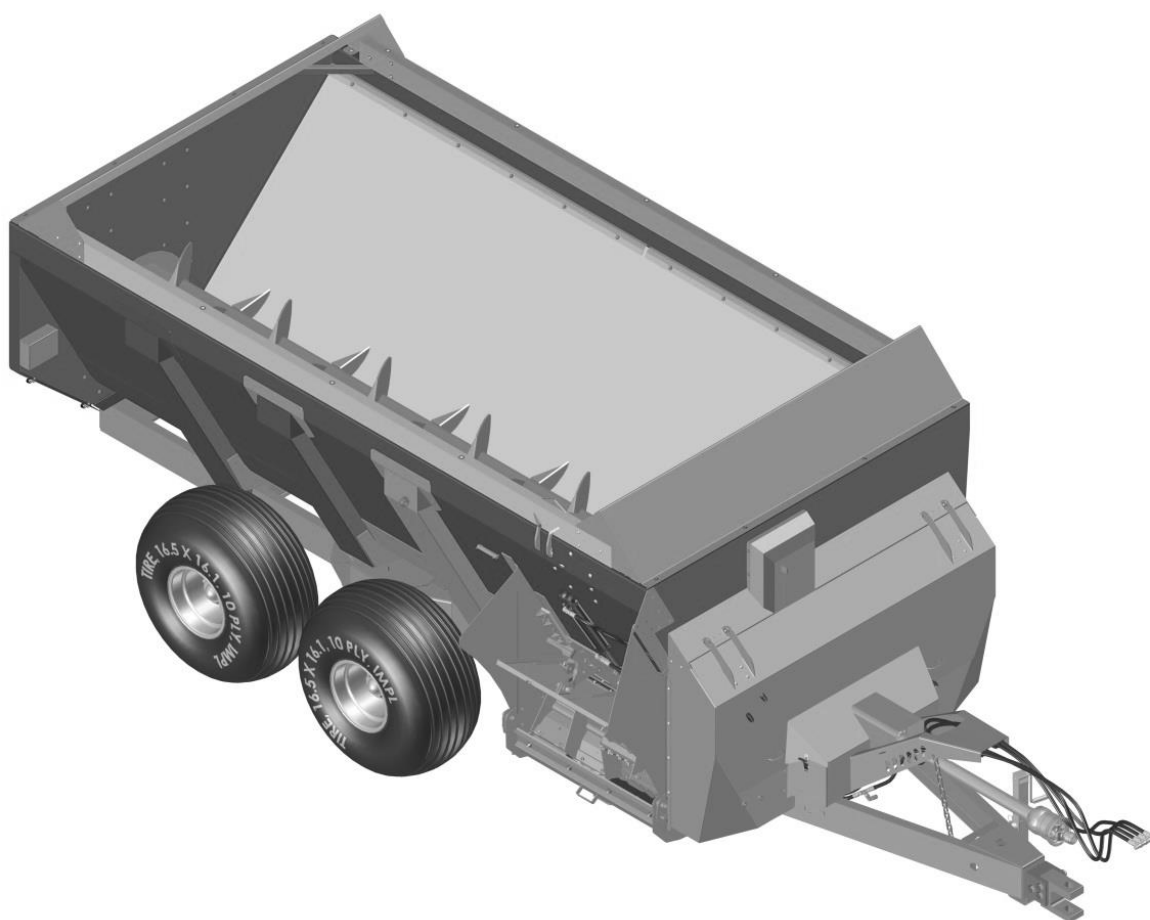

Revision #00
Starting Ser.#612252

Part #73356
HSMF0216

**P.O. BOX 768, MARSHFIELD, WI 54449
(715) 387-3414 FAX (715) 384-5463
www.hsmfgco.com**

CONTENTS

Instructions for Ordering Parts - About Improvements	1
Figure 1 - Auger/Liner/Slides/Hitch	2-5
Figure 2 - Auger Drive	6-9
Figure 3 - Expeller/Discharge Gate/Bearings	10-11
Figure 4 - Expeller/Discharge Gate/Door	12-13
Figure 5 - Expeller/Discharge Gate/Pan	14-15
Figure 6 - Input Shaft/Expeller Drive	16-19
Figure 7 - Guards/Shields	20-21
Figure 8 - Splash Guards/Rails	22-23
Figure 9 - Hydraulics	24-25
Figure 10 - Tandem Axles (5126)	26-27
Figure 11 - Oiler Kit.	28-29
Figure 12 - Front Grease Lines.	30-31
Figure 13 - Lighting.	32-33
Figure 14 - Auger.	34
Figure 15 - Auger Front & Rear Hydraulic Cylinder.	35
Figure 16 - 5126 Expeller Door Hydraulic Cylinder.	36
Figure 17 - Scale.	37
Figure 18 - PTO (OPTIONAL 540 RPM)	38
Figure 19 - PTO (1000 RPM).	39
Parts Notes	40

INSTRUCTIONS FOR ORDERING PARTS

All service parts should be ordered through your authorized H&S dealer. They will be able to give you faster service if you will provide them with the following

1. Model & Serial number is located on the main frame.
2. All reference to left or right apply to the *Top Shot* as viewed from the rear.
3. Parts should not be ordered from illustration only. Please order by complete part number.
4. If your dealer has to order parts - give shipping instructions:

VIA truck - large pieces (please specify local truck lines)

VIA United Parcel Service (include full address)

H&S MFG. CO. INC.	
MARSHFIELD, WIS.	
MOD. NO.	<input type="text"/>
SER. NO.	<input type="text"/>
DESCR.	<input type="text"/>

PLEASE RECORD NUMBERS FOR YOUR UNIT FOR QUICK REFERENCE

ABOUT IMPROVEMENTS

H&S IS CONTINUALLY STRIVING TO IMPROVE IT'S PRODUCTS

We must therefore, reserve the right to make improvements or changes whenever it becomes practical to do so without incurring any obligation to make changes or additions to the equipment previously sold.

FIGURE 1

AUGER/LINER/SLIDES/HITCH

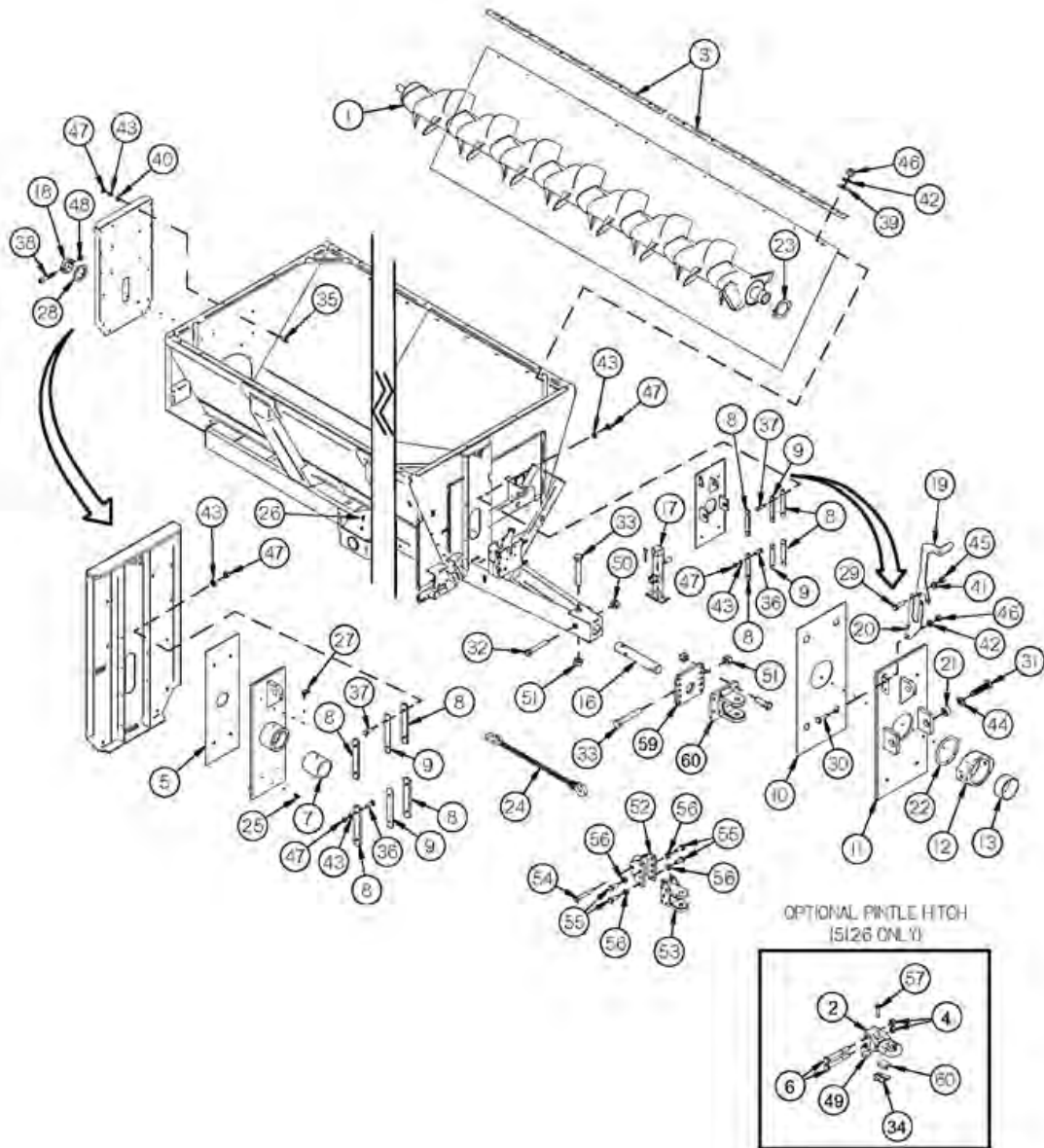

FIGURE 1

AUGER/LINER/SLIDES/HITCH

<u>ITEM</u>	<u>QTY</u>	<u>PART #</u>	<u>DESCRIPTION</u>
1	1	TS1	AUGER
2	1	YBHH24051	BOLT, 3/4 X 3 GR 5 FULL THREAD
*	1	TS3	TUB SIDE POLY
3	1	TS4	POLY TOP HOLD DOWN
4	4	YNTL32005	HEX NUT, TOP LOCK, 1"-8 GR. C, ZINC
*	1	TS6	BACK PANEL
5	1	TS7	BACK SLIDER POLY
6	2	YBHH32034	BOLT, 3/4" X 3" GR. 5 FULL THREAD
*	1	TS309	BACK SLIDER
7	1	TS9	REAR AUGER BUSHING
8	8	TS10	SLIDER GUIDE
9	4	TS308	SLIDER GUIDE THIN
10	1	TS11	FRONT POLY SLIDE
11	1	TS12	FRONT SLIDE PLATE
12	1	TS14	TRUNNION HOUSING
13	1	TS15	FRONT AUGER BEARING
*	1	TS399	TRUNNION HOUSING WITH BEARING
14	1	58557	BOLT, HEX HEAD, 1"-8 X 7-1/2" GR. 8
15	1	58558	BASE, PERFECT HITCH
16	1	GM73	HITCH BAR STRAIGHT
17	1	TS306	JACK, SIDE WIND, 7000 LBS
18	1	TS19	AUGER BACK COLLAR
19	1	TS207	AUGER INDICATOR TOP
20	1	TS208	AUGER INDICATOR BOTTOM
21	2	TS330	TRUNNION PIVOT BUSHING
22	1	TS33	AUGER SPROCKET RUBBER GASKET
23	1	TS102	TRUNION SPACER
24	1	SC40500	SAFETY CHAIN #40500
25	4	G89	1/4" GREASE ZERK
26	2	BFR28	1/8" NPT GREASE ZERK

NOTE: * MEANS NOT SHOWN

FIGURE 1

AUGER/LINER/SLIDES/HITCH

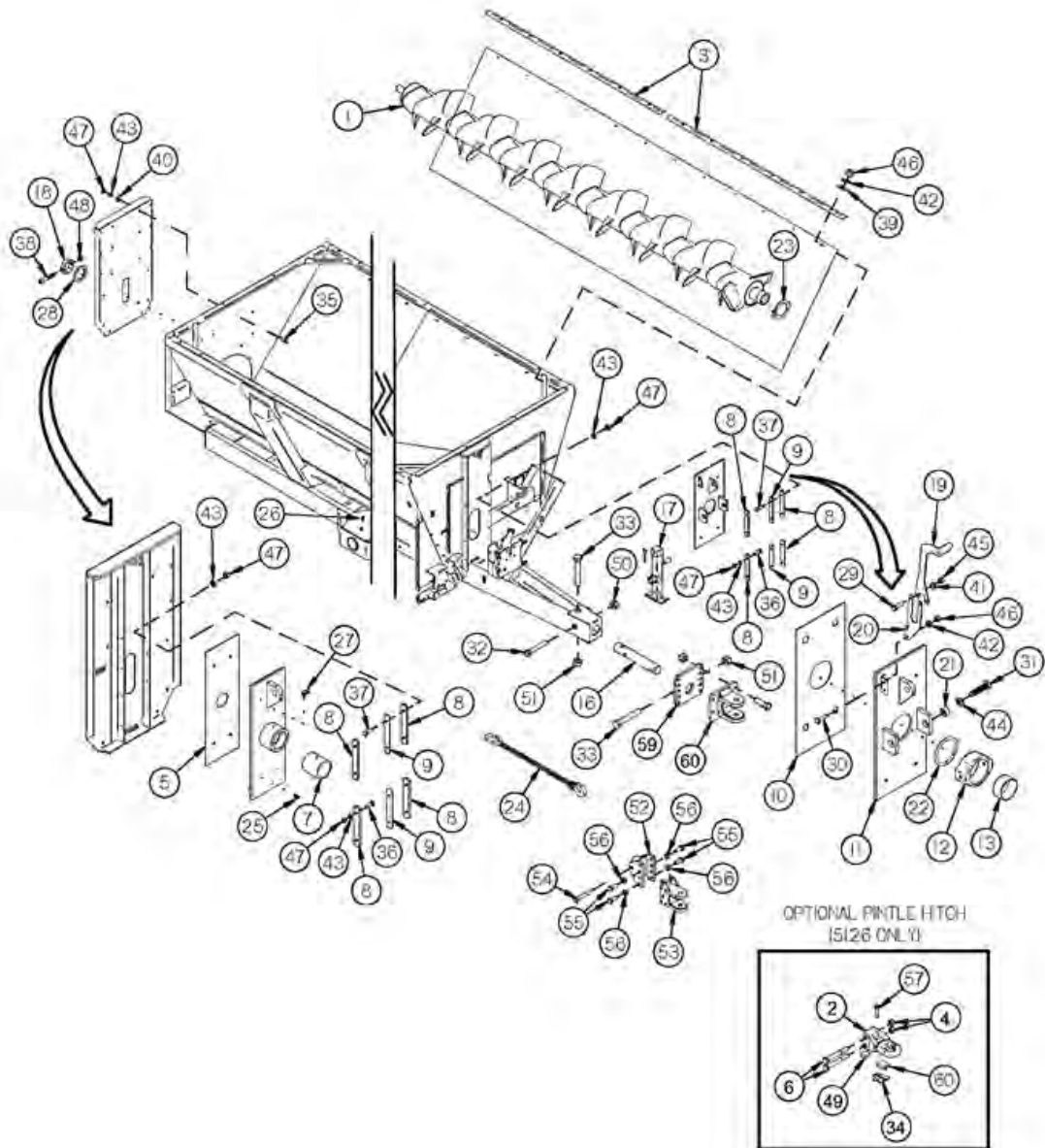

FIGURE 1

AUGER/LINER/SLIDES/HITCH

ITEM	QTY	PART #	DESCRIPTION
27	1	RG51	90° GREASE ZERK
28	A/R	TS227	SPACER 2-17/32" (THICK)
*	A/R	TS28	SPACER 2-17/32" (THIN)
29	2	YBHH08100	BOLT, 1/4" X 3/4" GR. 5
30	2	YBHH10105	BOLT, 5/16" X 3/4" GR. 5
31	2	YBHH20022	BOLT, 5/8" X 1-3/4" GR. 8
32	1	YBHH24083	BOLT, 3/4" X 5" GR. 8
33	1	YBHH32023	BOLT, 1" X 5" GR. 8
34	1	58559	BLOCK, V PLATE, TOP
35	18	YBCR12010	CARR. BOLT, 3/8" X 1" GR. 5
36	8	YBCR12020	CARR. BOLT, 3/8" X 1-1/4" GR. 5
37	8	YBCR12015	CARR. BOLT, 3/8" X 1-1/2" GR. 5
38	1	YSHS12018	SOCKET HEAD CAP SCREW, 3/8" X 4"
39	12	YWFL10005	WASHER, FLAT, 5/16" USS
40	18	YWFL12005	WASHER, FLAT, 3/8" USS
41	2	YWLO08005	WASHER, LOCK, 1/4"
42	14	YWLO10005	WASHER, LOCK, 5/16"
43	34	YWLO12005	WASHER, LOCK, 3/8"
44	2	YWLO20005	WASHER, LOCK, 5/8"
45	2	YNHX08005	HEX NUT, 1/4"-20
46	14	YNHX10005	HEX NUT, 5/16"
47	34	YNHX12005	HEX NUT, 3/8"-16
48	1	YNTL12005	HEX NUT, TOP LOCK, 3/8"-16
49	1	58544	CUSHION
50	1	YNRL24005	HEX NUT, REVERSIBLE-SIDE LOCK, 3/4"-10
51	2	YNRL32005	HEX NUT, REVERSIBLE-SIDE LOCK, 1"-8
52	1	58532	PINTLE HITCH RECEIVER
53	1	58538	ADJUSTABLE CLEVIS
54	1	YBHH32028	BOLT, 1" X 6-1/2" GR. 8 (YELLOW ZINC)
55	4	YBHH32008	BOLT, 1"-8 X 2-1/4" GR. 5

NOTE: * MEANS NOT SHOWN
A/R: MEANS AS REQUIRED

FIGURE 2

AUGER DRIVE

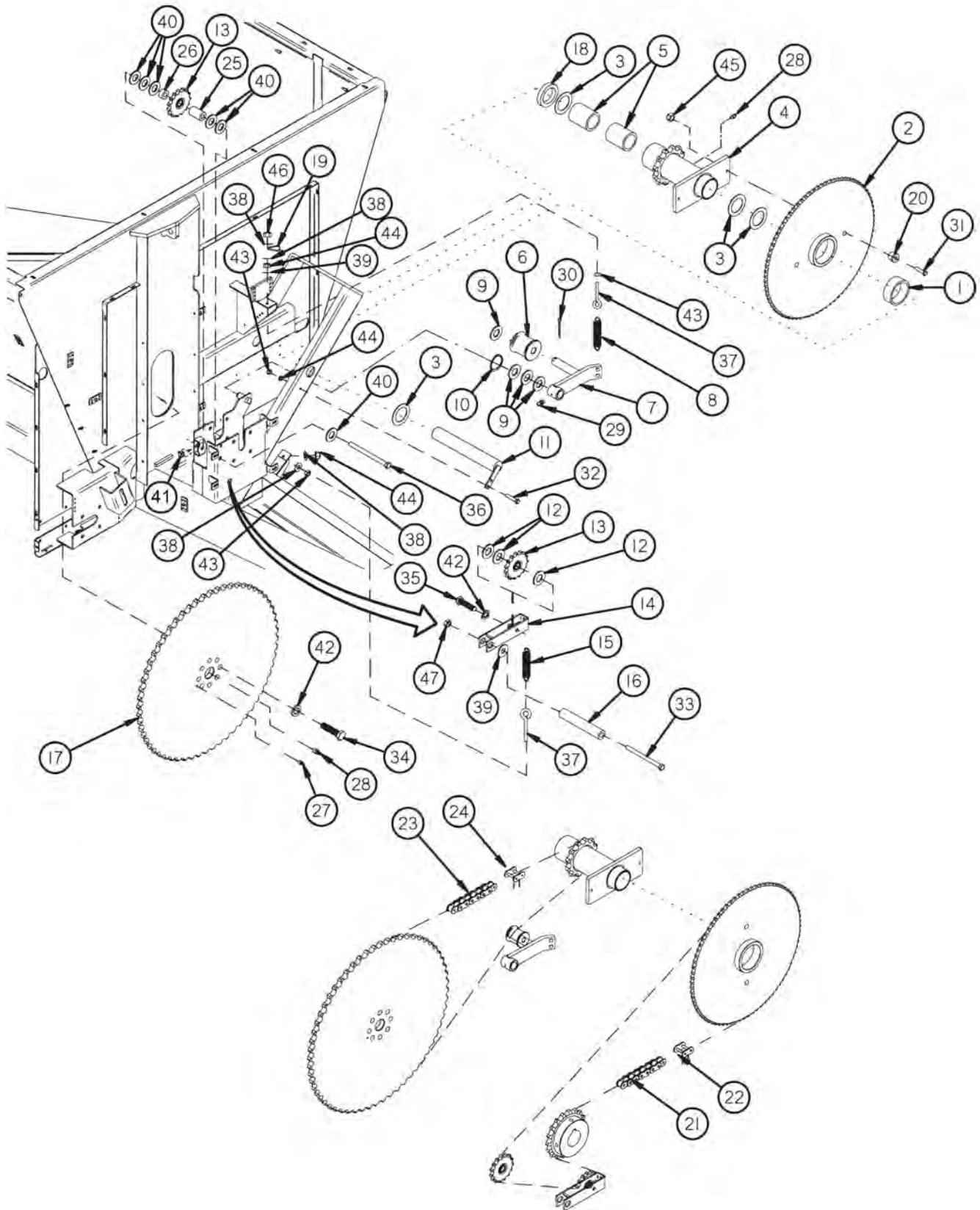

FIGURE 2

AUGER DRIVE

<u>ITEM</u>	<u>QTY</u>	<u>PART #</u>	<u>DESCRIPTION</u>
1	1	TS20	BUSHING/BRONZE
2	1	TS21	SPROCKET/ASSY 80T (STANDARD 540 RPM)
*	1	TS312	SPROCKET/ASSY 119T (STANDARD 1000 RPM)
3	A/R	TS22	SPACER, 2"
*	A/R	56N183	SPACER
4	1	TS23	COUNTER SHAFT ASSEMBLY
5	2	TS24	BRONZE BUSHING
6	1	TS25	ROLLER IDLER
7	1	TS26	AUGER CHAIN TENSIONER
8	1	BFR138	SPRING
9	3	S345	1" SPACER
10	1	3G21	SNAP RING
11	1	TS27	COUNTER SHAFT
12	A/R	T73	SPACER
*	A/R	16SV49	SPACER
13	2	TS29	SPROCKET/IDLER ASSY
14	1	TS30	IDLER ASSY
15	1	ST36	SPRING/EXTENSION
*	1	GM410	SPRING (1000 RPM ONLY)
16	1	TS31	TENSIONER PIVOT TUBE
17	1	TS32	SPROCKET #100x60T ASSY
18	1	TS328	REDUCTION LARGE SPACER
19	1	HGV72	SMALL TUBE HOLDER
20	2	TS34	HARDENED SHEAR BUSHING
21	1	TS39	CHAIN/ROLLER #60HE X 138 (540 RPM - 18T & 15T SPROCKETS)
*	1	TS360	CHAIN/ROLLER #60HE X 136 (540 RPM - 13T SPROCKET)
*	1	TS361	CHAIN/ROLLER #60HE X 140 (540 RPM - 20T SPROCKET)
*	1	TS313	CHAIN/ROLLER #60HE X 166 (1000 RPM - 15T SPROCKET)
*	1	TS362	CHAIN/ROLLER #60HE X 165 (1000 RPM - 13T SPROCKET)
*	1	TS363	CHAIN/ROLLER #60HE X 167 (1000 RPM - 16T SPROCKET)

NOTE: * MEANS NOT SHOWN

FIGURE 2

AUGER DRIVE

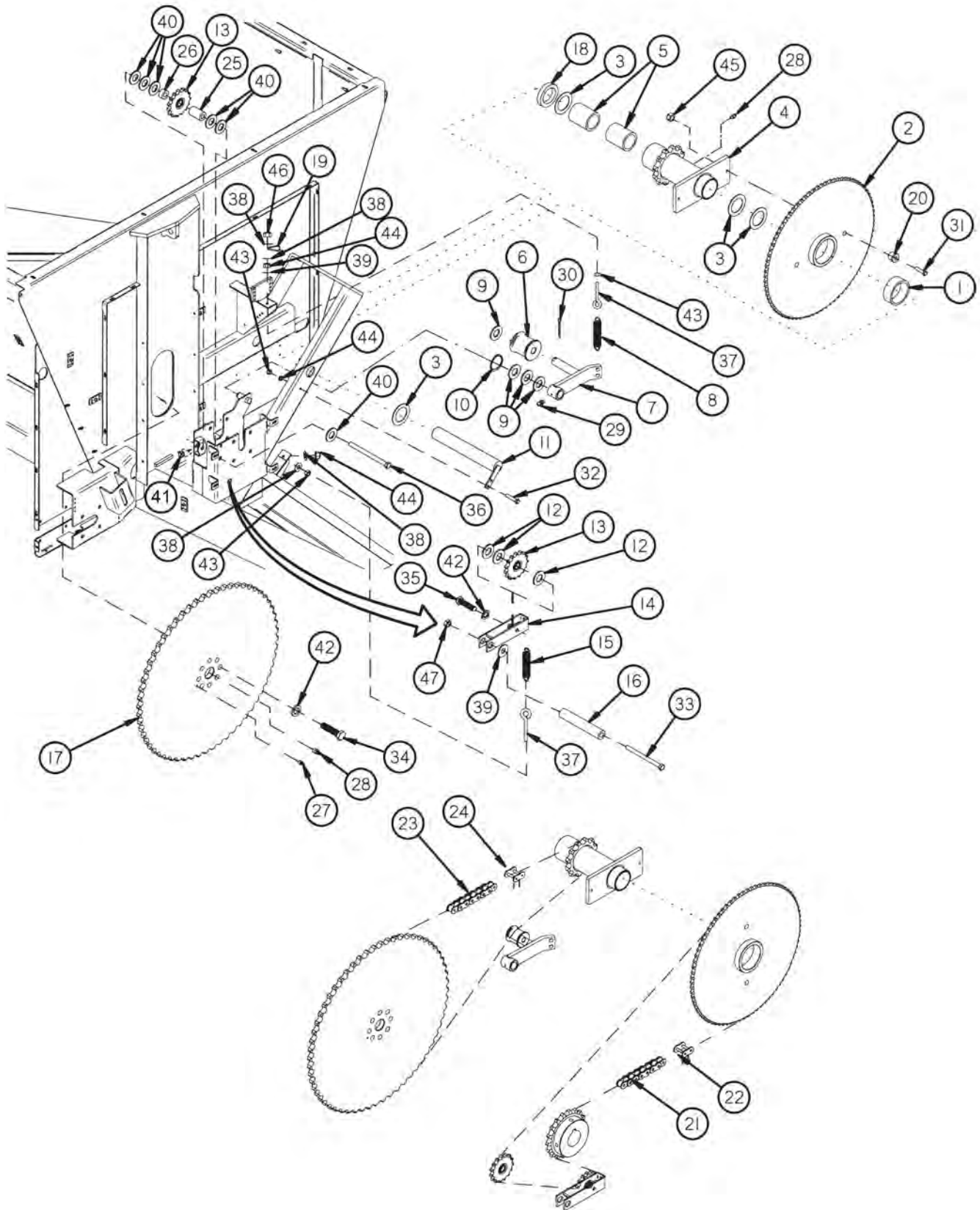

FIGURE 2

AUGER DRIVE

<u>ITEM</u>	<u>QTY</u>	<u>PART#</u>	<u>DESCRIPTION</u>
22	1	TS40	LINK/CONNECTOR #60HE
23	1	TS41	CHAIN/ROLLER #100HE X 75
24	1	TS42	LINK/CONNECTOR #100HE
25	1	TS396	IDLER FRONT SPACER
26	1	TS397	IDLER REAR SPACER
27	1	G89	GREASE ZERK
28	2	BFR28	1/8" NPT GREASE ZERK #1610
29	1	RG51	1/4"-28 90° GREASE ZERK #1911
30	1	YPCT06005	COTTER PIN, 3/16" X 1-1/2"
31	2	YBHH10036	BOLT, 5/16" X 1-1/2" GR. 8 YELLOW ZINC
*	4	YBHH10036	BOLT, 5/16" X 1-1/2" GR. 8 YELLOW ZINC
32	1	YBHH12100	BOLT, 3/8" X 2-1/4" GR. 5
33	1	YBHH16175	BOLT, 1/2" X 6-1/2" GR. 5
34	8	YBHH20036	BOLT, 5/8" X 2-1/2" GR. 8 YELLOW ZINC
35	1	YBHH20025	BOLT, 5/8" X 2" GR. 5
36	1	YBHH20100	BOLT, 5/8" X 6" GR. 5
37	2	YBTE12025	TURNED EYE BOLT, 3/8" X 3" FULL THREAD
38	4	YWFL12005	WASHER, FLAT, 3/8" USS
39	2	YWFL16005	WASHER, FLAT, 1/2" USS
40	A/R	YWFL20005	WASHER, FLAT, 5/8" USS
41	1	YNTJ20005	HEX NUT, TOP LOCK, JAM, 5/8"-11, ZINC FINISH GRADE A
42	9	YWLO20005	WASHER, LOCK, 5/8"
43	3	YNHX12005	HEX NUT, 3/8"-16
44	2	YNNY12005	HEX NUT, NYLON LOCKNUT, 3/8"
45	2	YNTL10005	HEX NUT, TOP LOCK, 5/16"-18
46	1	YNTL12005	HEX NUT, TOP LOCK, 3/8"-16
47	1	YNTJ16005	HEX NUT, TOP LOCK, JAM, 1/2"-13

NOTE: * MEANS NOT SHOWN
A/R: MEANS AS REQUIRED

FIGURE 3

EXPELLER/DISCHARGE GATE/BEARINGS

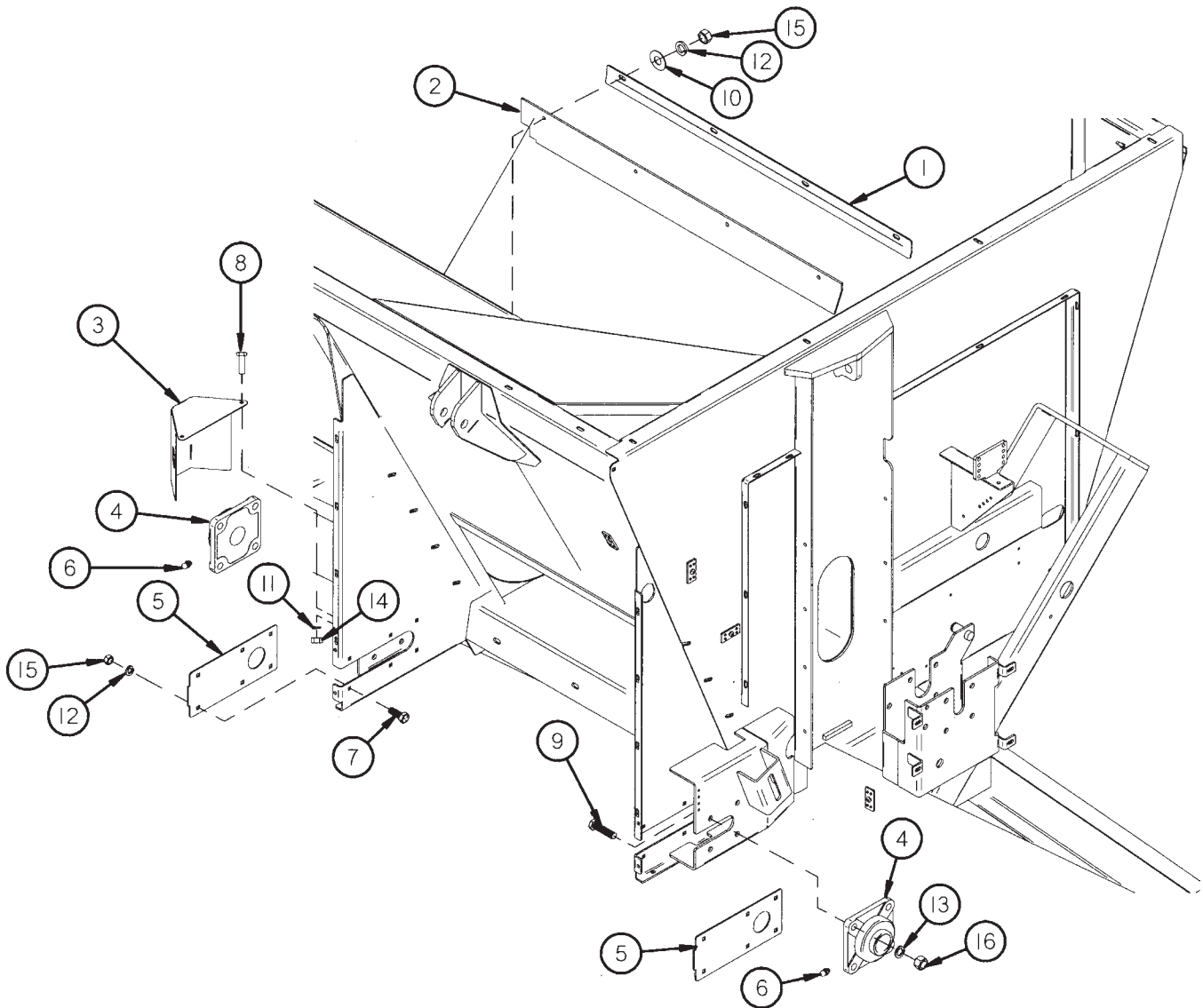

FIGURE 3

EXPELLER/DISCHARGE GATE/BEARINGS

<u>ITEM</u>	<u>QTY</u>	<u>PART #</u>	<u>DESCRIPTION</u>
1	1	TS43	DOOR SEAL CLAMP
2	1	TS44	EXPELLER DOOR TOP SEAL
3	1	TS45	EXPELLER BEARING SHIELD
4	2	HGV41	EXPELLER BEARING
5	2	TS47	COVER PLATE
6	2	G89	GREASE ZERK
7	12	YBCR12010	CARR. BOLT, 3/8" X 1" GR. 5
8	2	YBHH08100	BOLT, 1/4" X 3/4" GR. 5
9	8	YBHH18010	BOLT, 9/16" X 1-3/4" GR. 5
10	4	YWFL12005	WASHER, FLAT, 3/8" USS
11	2	YWLO08005	WASHER, LOCK, 1/4"
12	16	YWLO12005	WASHER, LOCK, 3/8"
13	8	YWLO18005	WASHER, LOCK, 9/16"
14	2	YNHX08005	HEX NUT, 1/4"-20
15	16	YNHX12005	HEX NUT, 3/8"-16
16	8	YNHX18005	HEX NUT, 9/16"-12

FIGURE 4
EXPELLER/DISCHARGE GATE/DOOR

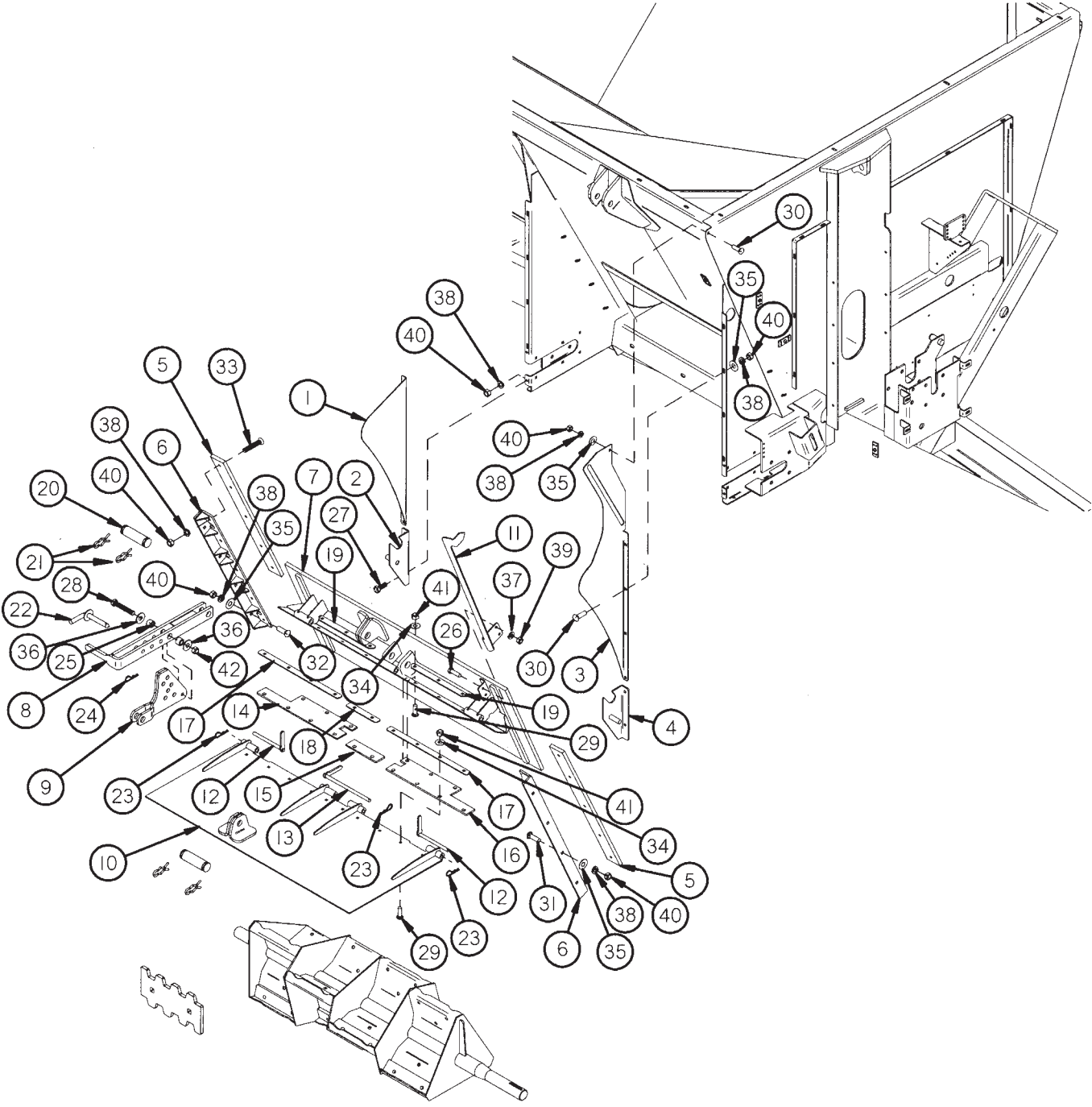

FIGURE 4

EXPELLER/DISCHARGE GATE/DOOR

<u>ITEM</u>	<u>QTY</u>	<u>PART #</u>	<u>DESCRIPTION</u>
1	1	TS48	EXPELLER PANEL EXTENSION LEFT HAND
2	1	TS49	PAN HINGE BRACKET LEFT
3	1	TS50	EXPELLER PANEL EXTENSION RIGHT HAND
4	1	TS51	PAN HINGE BRACKET RIGHT
5	2	TS52	DOOR SLIDER POLY
6	2	TS53	EXPELLER DOOR GUIDE
7	1	TS54	EXPELLER DOOR
8	1	TS55	DEFLECTOR ADJUSTMENT HANDLE
9	1	TS56	DEFLECTOR ADJUSTMENT LINK
10	1	TS57	ADJUSTABLE FLAT DEFLECTOR
11	1	TS58	DOOR INDICATOR
12	2	TS59	DEFLECTOR SIDE PIN
13	1	TS60	DEFLECTOR MID PIN
14	1	TS61	DEFLECTOR SEAL LEFT
15	1	TS62	DEFLECTOR SEAL MID
16	1	TS63	DEFLECTOR SEAL RIGHT
17	2	TS64	SEAL STRAP LONG
18	1	TS65	SEAL STRAP MID
19	2	TS66	SEAL STRAP SHORT
20	2	T143	CYLINDER PIN
21	4	T144	CLIP PIN
22	1	TS69	CASTER LOCKING PIN
23	3	YPHR02005	HAIR PIN
24	1	WM378	HAIR PIN W/ LANYARD
25	2	TS307	HANDLE PIVOT
26	2	YBHH10105	BOLT, 5/16" X 3/4" GR. 5
27	4	YBHH12010	BOLT, 3/8" X 1" GR. 5
28	1	YBHH16105	BOLT, 1/2" X 3" GR. 5
29	16	YBCR10010	CARR. BOLT, 5/16" X 1" GR. 5
30	9	YBCR12010	CARR. BOLT, 3/8" X 1" GR. 5
31	7	YBCR12020	CARR. BOLT, 3/8" X 1-1/4" GR. 5
32	1	YBCR12015	CARR. BOLT, 3/8" X 1-1/2" GR. 5
33	10	YSFS12005	FLAT HEAD SOCKET CAP SCREW, 3/8" X 1-1/4"
34	16	YWFL10005	WASHER, FLAT, 5/16" USS
35	17	YWFL12005	WASHER, FLAT, 3/8" USS
36	2	YWFL16005	WASHER, FLAT, 1/2" USS
37	2	YWLO10005	WASHER, LOCK, 5/16"
38	31	YWLO12005	WASHER, LOCK, 3/8"
39	2	YNHX10005	HEX NUT, 5/16"
40	31	YNHX12005	HEX NUT, 3/8"-16
41	16	YNTL10005	HEX NUT, TOP LOCK, 5/16"-18
42	1	YNTL16005	HEX NUT, TOP LOCK, 1/2"-13

FIGURE 5
EXPELLER/DISCHARGE GATE/PAN

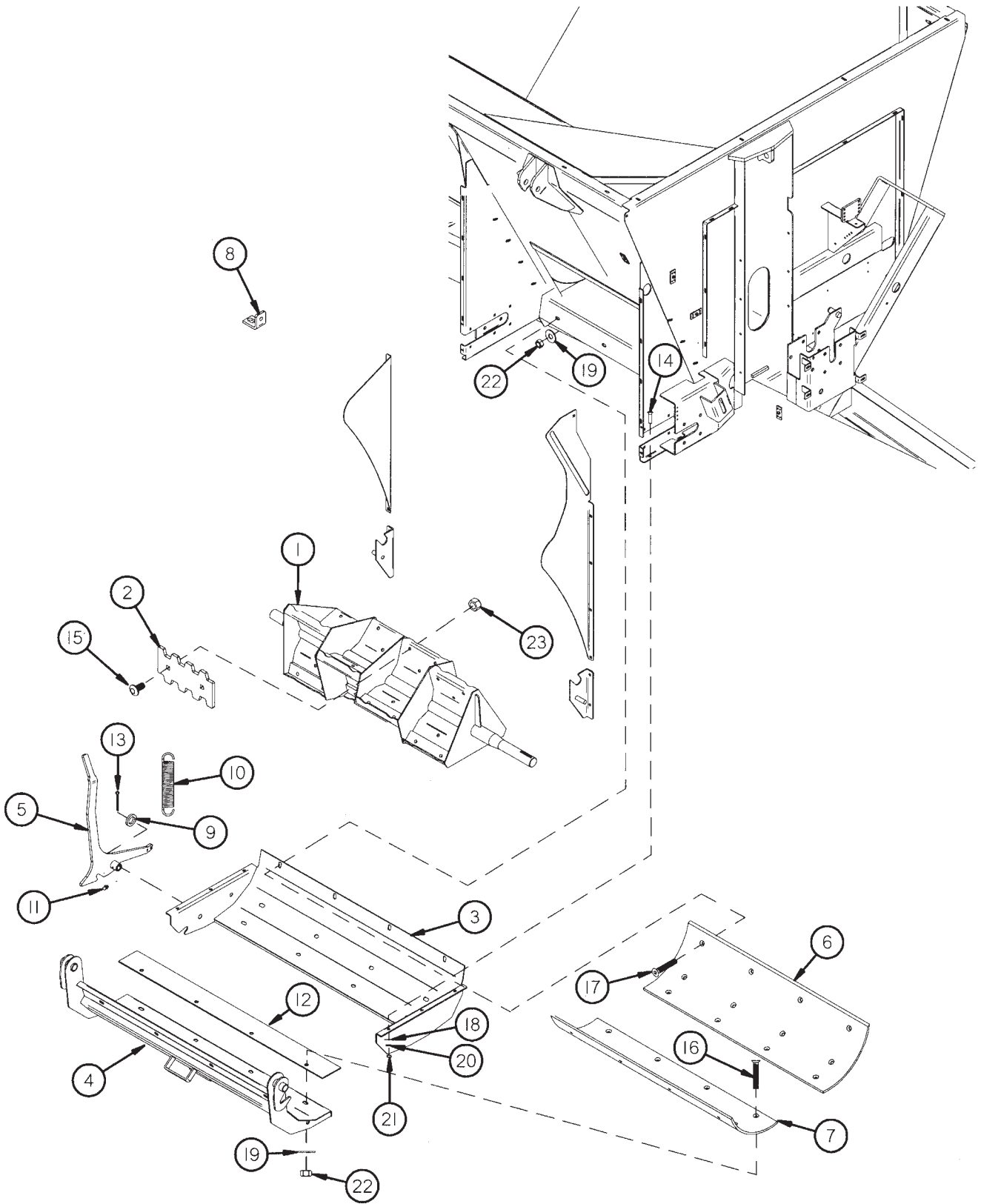

FIGURE 5

EXPELLER/DISCHARGE GATE/PAN

<u>ITEM</u>	<u>QTY</u>	<u>PART #</u>	<u>DESCRIPTION</u>
1	1	69616	EXPELLER
2	12	TS68	EXPELLER PADDLE
3	1	TS72	SWING AWAY PAN FRAME
4	1	TS73	SWING AWAY PAN
5	1	TS74	PAN LATCH HANDLE
6	1	TS75	EXPELLER BACK POLY
7	1	TS76	EXPELLER PAN POLY
8	1	56N146	SHIELD ANGLE
9	3	T73	SPACER
10	1	K103	SPRING
11	1	G89	GREASE ZERK
12	1	TS18	PAN RUBBER SEAL
13	1	YPCT06010	COTTER PIN, 3/16" X 1-1/4"
14	6	YBCR10010	CARR. BOLT, 5/16" X 1" GR. 5
15	24	YBCR16019	SHAKER SCREEN BOLT, 1/2" X 1-3/4" GR. 8
16	20	YSFS16010	FLAT HEAD SOCKET CAP SCREW, 1/2" X 1-1/2"
17	4	YSFS16020	FLAT HEAD SOCKET CAP SCREW, 1/2" X 1-3/4"
18	6	YWFL10005	WASHER, FLAT, 5/16" USS
19	24	YWFL16005	WASHER, FLAT, 1/2" USS
20	6	YWLO10005	WASHER, LOCK, 5/16"
21	6	YNHX10005	HEX NUT, 5/16"
22	24	YNRL16005	HEX NUT, REVERSIBLE-SIDE LOCK, 1/2"-13
23	24	YNTL16006	HEX NUT, TOP LOCK, 1/2"-13 GR. 9

FIGURE 6

INPUT SHAFT/EXPELLER DRIVE

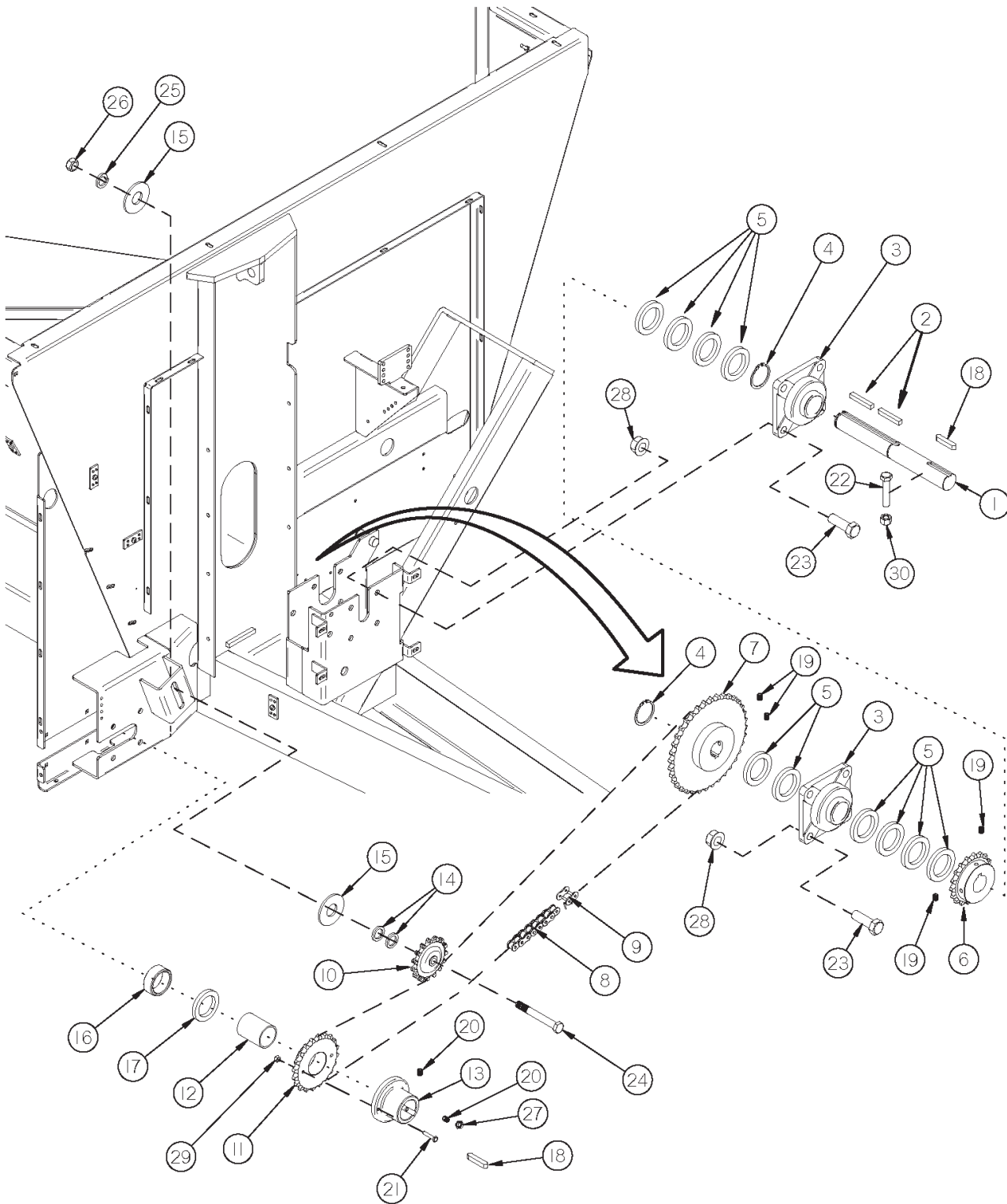

FIGURE 6

INPUT SHAFT/EXPELLER DRIVE

<u>ITEM</u>	<u>QTY</u>	<u>PART #</u>	<u>DESCRIPTION</u>
1	1	57392	INPUT SHAFT
2	2	68856	KEY, SQUARE, 3/8" X 1-1/4"
3	2	12V99	BEARING
4	2	12V62	SNAP RING
5	A/R	16SV374	SPACER
*	A/R	16SV375	SPACER
*	A/R	16SV439	SPACER
*	1	33SV29	SPACER
6	1	TS35	SPROCKET/60B18 (STANDARD - 540 RPM)
*	1	TS36	SPROCKET/ASSY 13T (OPTIONAL - 540 RPM & 1000 RPM)
*	1	TS37	SPROCKET/60B15T (OPT. - 540 RPM) (STANDARD - 1000 RPM)
*	1	TS38	SPROCKET/60B20 (OPTIONAL - 540 RPM)
*	1	TS364	SPROCKET/60B16 (OPTIONAL - 1000 RPM)
7	1	TS79	SPROCKET/60B36 (STANDARD - 540 RPM)
*	1	TS80	SPROCKET/EXP DRIVE ASSY 30T (OPTIONAL - 540 RPM)
*	1	TS81	SPROCKET/60X27T (OPTIONAL - 540 RPM)
*	1	TS38	SPROCKET/60B20 (OPTIONAL - 1000 RPM)
*	1	TS318	SPROCKET/ASSY 16T (OPTIONAL - 1000 RPM)
*	1	TS365	SPROCKET/ASSY 15T (OPTIONAL - 1000 RPM)
*	1	TS366	SPROCKET/ASSY 13T (OPTIONAL - 1000 RPM)
8	1	TS82	CHAIN/ROLLER #60HE X 100 (540 RPM - 36T SPROCKET)
*	1	TS367	CHAIN/ROLLER #60HE X 97 (540 RPM - 30T SPROCKET)
*	1	TS368	CHAIN/ROLLER #60HE X 96 (540 RPM - 27T SPROCKET)
*	1	TS316	CHAIN/ROLLER #60HE X 92 (1000 RPM - 20T SPROCKET)
*	1	TS369	CHAIN/ROLLER #60HE X 90 (1000 RPM - 16T SPROCKET)
*	1	TS370	CHAIN/ROLLER #60HE X 89 (1000 RPM - 15T SPROCKET)
*	1	TS371	CHAIN/ROLLER #60HE X 88 (1000 RPM - 13T SPROCKET)

NOTE: * MEANS NOT SHOWN

A/R: MEANS AS REQUIRED

FIGURE 6

INPUT SHAFT/EXPELLER DRIVE

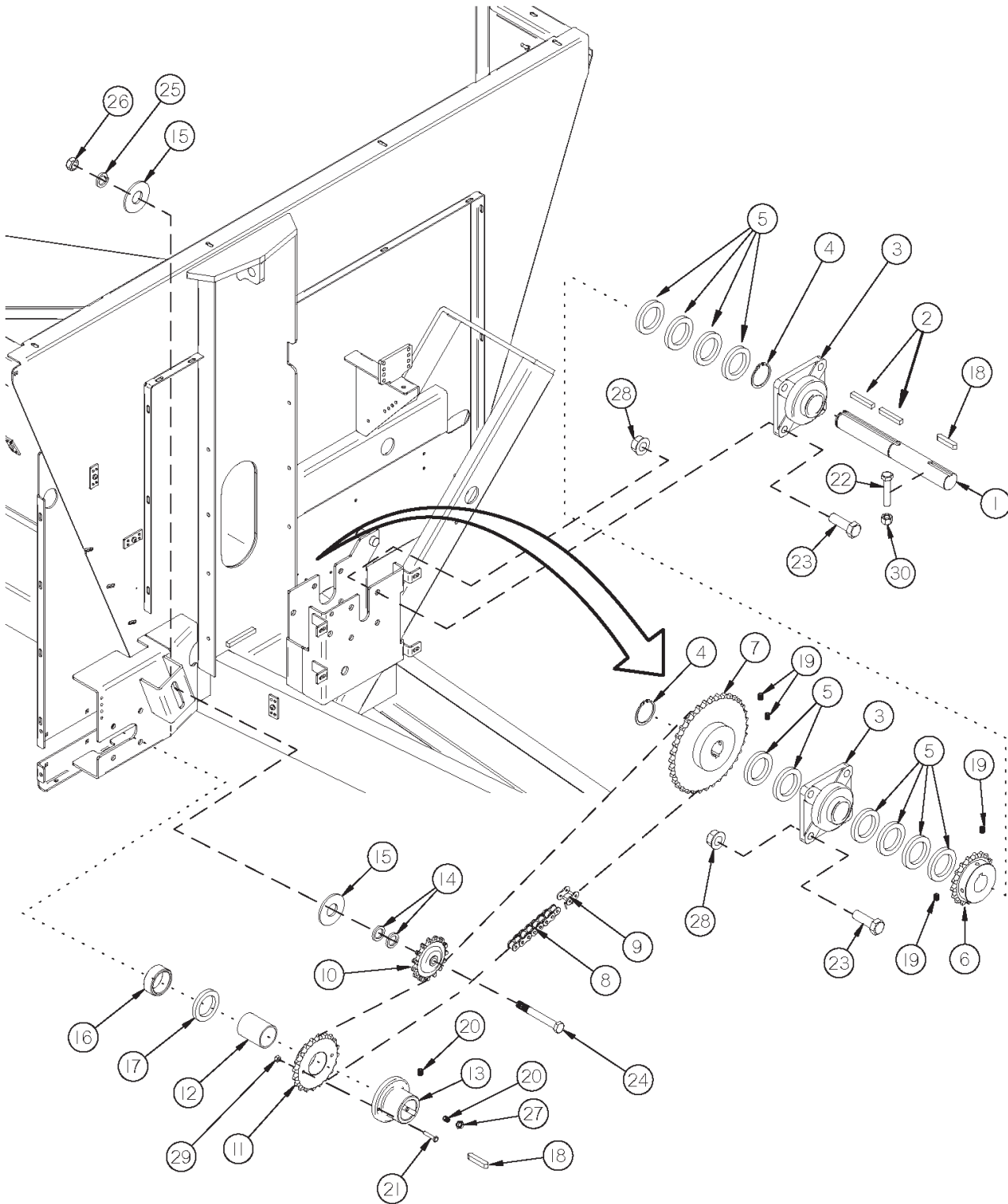

FIGURE 6

INPUT SHAFT/EXPELLER DRIVE

<u>ITEM</u>	<u>QTY</u>	<u>PART #</u>	<u>DESCRIPTION</u>
9	1	TS40	LINK/CONNECTOR #60HE
10	1	TS29	SPROCKET/IDLER ASSY
11	1	TS84	SPROCKET/ASSY 20T
12	1	TS85	BUSHING/BRONZE
13	1	TS86	EXPELLER SOLID SHEAR HUB
14	A/R	T73	SPACER
15	2	F129	TIGHTENER WASHER
16	1	TS329	EXPELLER DRIVE SPACER
17	A/R	S36	SHIM, 3/16" THICK
*	A/R	S409	SHIM, 1/8" THICK
18	2	S138	3/8" X 2-3/8" SQ. KEY W/ ROUND ENDS
19	4	YSKP10010	SET SCREW, SOCKET, KNURLED CUP PT, 5/16" - 18 X 3/8"
20	2	YSKP12010	SET SCREW, SOCKET, KNURLED CUP PT, 3/8"-16 X 1/2"
21	2	YBHH08027	BOLT, 1/4" X 1-1/2" GR. 8 YELLOW ZINC
*	4	YBHH08027	BOLT, 1/4" X 1-1/2" GR. 8 YELLOW ZINC
22	1	YBHH16080	BOLT, 1/2" X 2 - 1/2" GR. 5 (540 RPM PTO)
23	8	YBHH18005	BOLT, 9/16" X 1-1/2" GR. 5
24	1	YBHH20055	BOLT, 5/8" X 3-1/2" GR. 5
25	1	YWLO20005	WASHER, LOCK, 5/8"
26	1	YNHX20005	HEX NUT, 5/8"-11
27	1	YNJM12005	HEX NUT, JAM, 3/8"-16
28	8	YNFG18005	SERRATED FLANGE NUT, 9/16"
29	2	YNTL08005	HEX NUT, TOP LOCK, 1/4"-20
30	1	YNTL16005	HEX NUT, TOP LOCK, 1/2" - 13 (540 RPM PTO)

NOTE: * MEANS NOT SHOWN

A/R: MEANS AS REQUIRED

FIGURE 7
GUARDS/SHIELDS

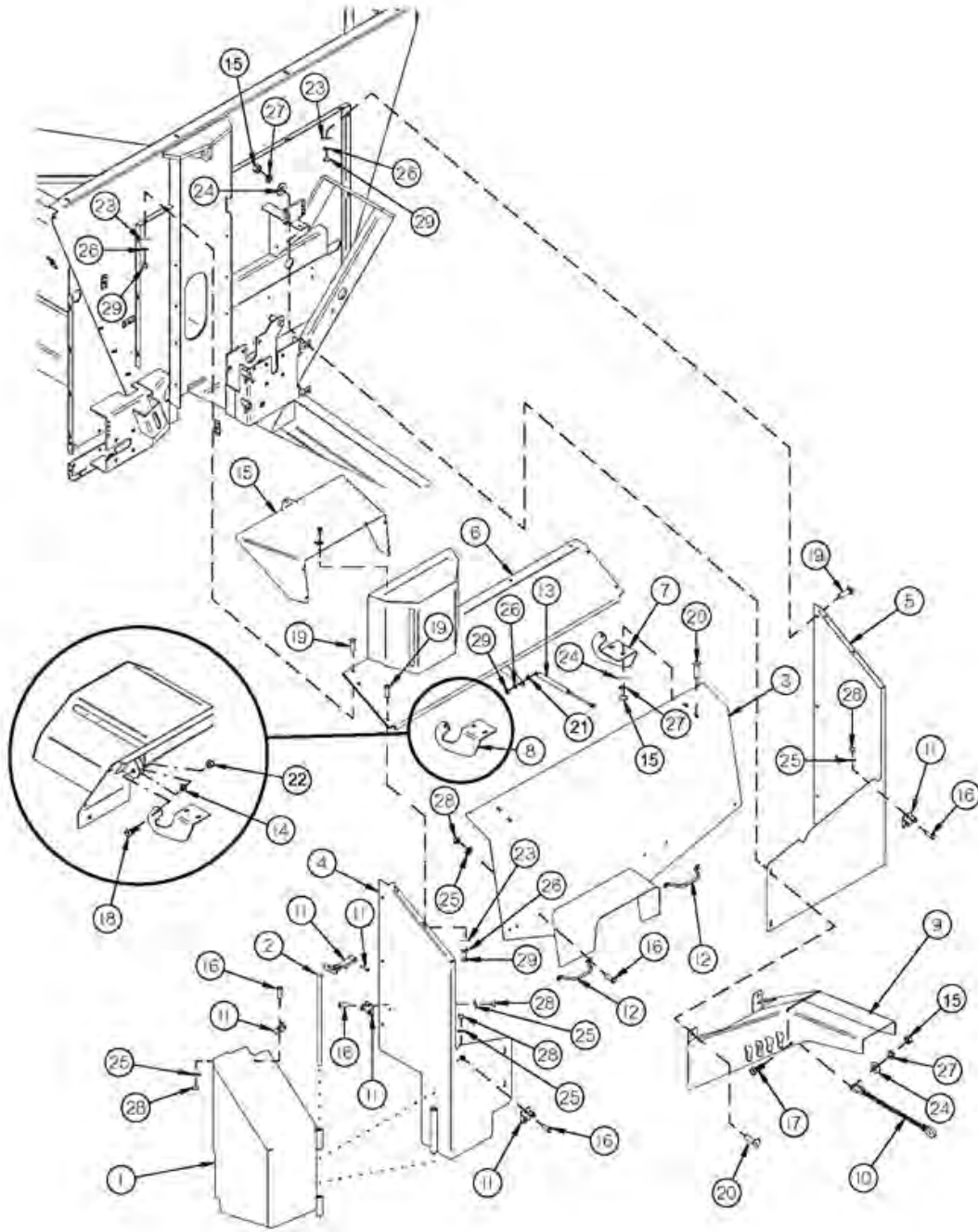

FIGURE 7

GUARDS/SHIELDS

<u>ITEM</u>	<u>QTY</u>	<u>PART #</u>	<u>DESCRIPTION</u>
1	1	TS87	EXPELLER DRIVE SHIELD
2	1	TS88	EXPELLER SHIELD HINGE
3	1	TS89	FRONT SHIELD DOOR
4	1	TS90	FRONT SHIELD RIGHT SIDE
5	1	TS91	FRONT SHIELD LEFT SIDE
6	1	TS92	FRONT SHIELD TOP
7	1	TS93	FRONT SHIELD HINGE RIGHT
8	1	TS94	FRONT SHIELD HINGE LEFT
9	1	TS95	HOSE HOLDER
10	1	TS130	CHAIN PTO HOLDER
11	12	X233	COMPLETE LATCH
12	2	TS96	SHIELD HANDLE
13	1	TS97	GAS SPRING 100 LBS FORCE 13.74" EXT LNG
14	4	TS331	SPACER
15	9	YNHX12005	HEX NUT, 3/8"-16
16	8	YBHH08015	BOLT, 1/4" X 1/2" GR. 5
17	1	YBHH12010	BOLT, 3/8" X 1" GR. 5
18	2	YBHH12035	BOLT, 3/8" X 1-1/4" GR. 5
19	13	YBCR10030	CARR. BOLT, 5/16" X 3/4" GR. 5
20	8	YBCR12010	CARR. BOLT, 3/8" X 1" GR. 5
21	2	YNJM10005	HEX NUT, JAM, 5/16"
22	2	YNTL12005	HEX NUT, TOP LOCK, 3/8"-16
23	13	YWFL10005	WASHER, FLAT, 5/16" USS
24	9	YWFL12005	WASHER, FLAT, 3/8" USS
25	8	YWLO08005	WASHER, LOCK, 1/4"
26	13	YWLO10005	WASHER, LOCK, 5/16"
27	9	YWLO12005	WASHER, LOCK, 3/8"
28	8	YNHX08005	HEX NUT, 1/4"-20
29	13	YNHX10005	HEX NUT, 5/16"

FIGURE 8
SPLASH GUARDS/RAILS

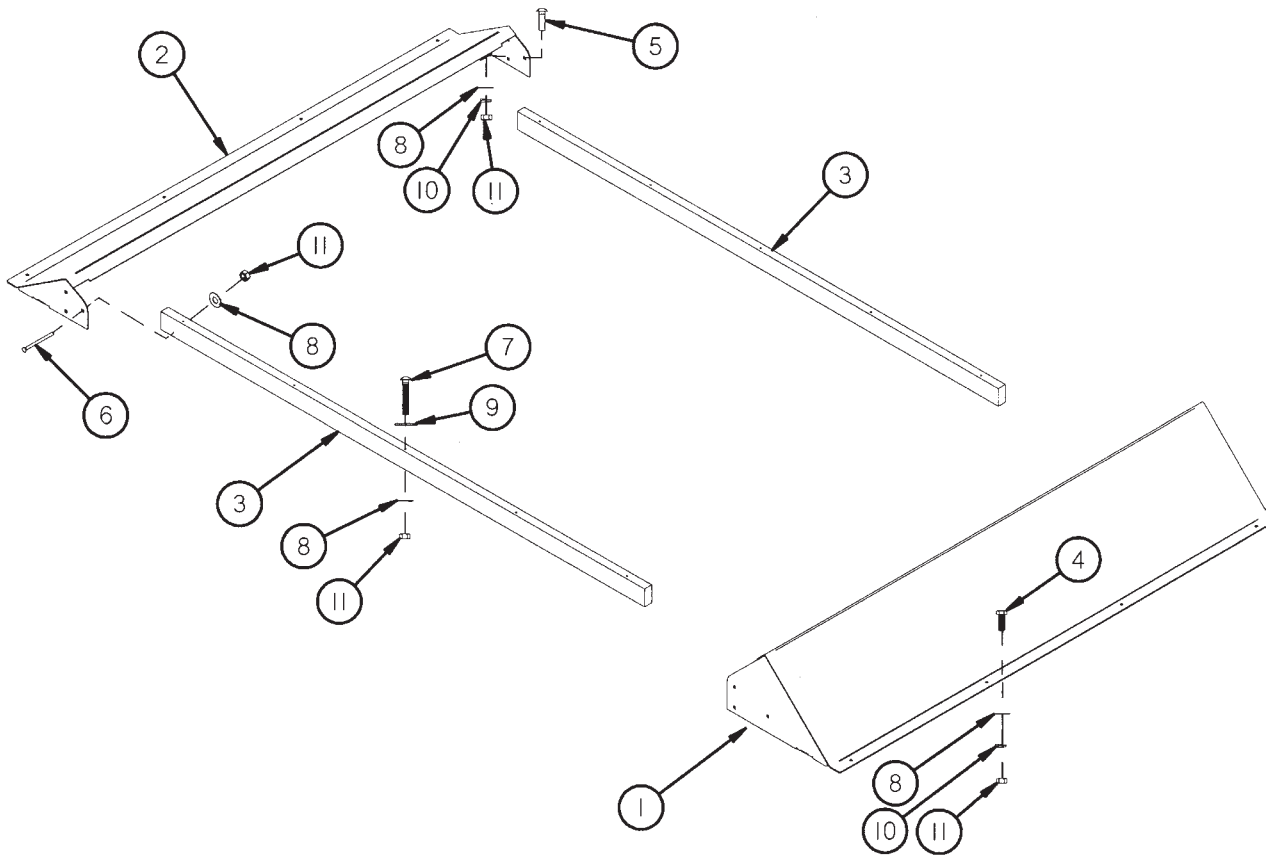

FIGURE 8

SPLASH GUARDS/RAILS

<u>ITEM</u>	<u>QTY</u>	<u>PART #</u>	<u>DESCRIPTION</u>
1	1	TS310	SPLASH GUARD
2	1	TS311	BACK SPLASH GUARD
3	2	TS100	WOOD RAIL
4	8	YBHH12010	BOLT, 3/8" X 1" GR. 5
5	4	YBCR12010	CARR. BOLT, 3/8" X 1" GR. 5
6	12	YBCR12080	CARR. BOLT, 3/8" X 3-1/4" GR. 5
7	10	YBCR12123	CARR. BOLT, 3/8" X 6-1/2" GR. 5
8	34	YWFL12005	WASHER, FLAT, 3/8" USS
9	10	YWFL16005	WASHER, FLAT, 1/2" USS
10	12	YWLO12005	WASHER, LOCK, 3/8"
11	34	YNHX12005	HEX NUT, 3/8"-16

NOTE: * MEANS NOT SHOWN

FIGURE 9

HYDRAULICS

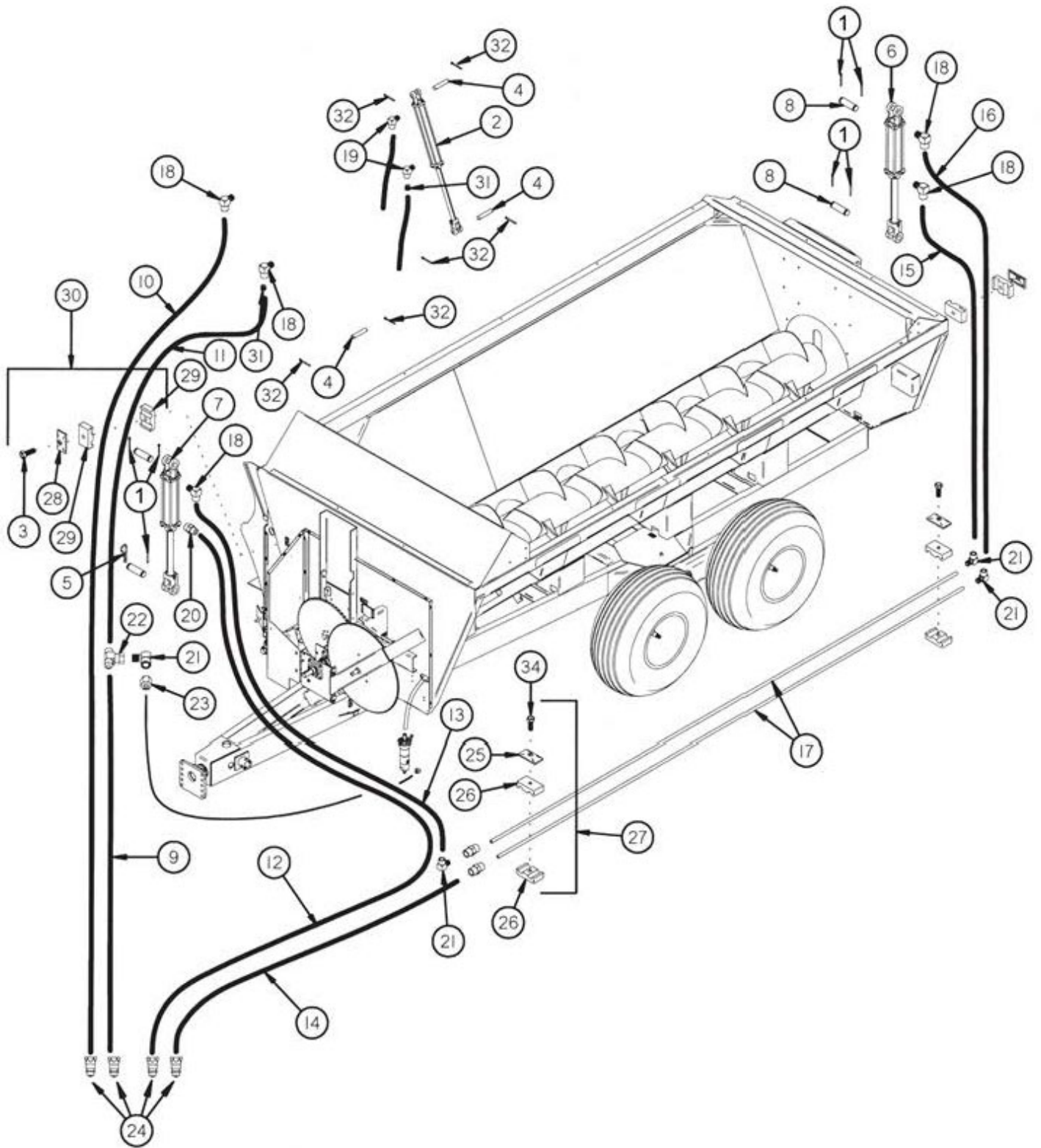

FIGURE 9

HYDRAULICS

<u>ITEM</u>	<u>QTY</u>	<u>PART #</u>	<u>DESCRIPTION</u>
1	7	YPCT06005	COTTER PIN, 3/16" X 1-1/2"
2	1	23N111A	2 X 16 CYLINDER
*	1	56015	2 X 16 CYLINDER
3	15	YBHH10030	BOLT, 5/16" X 1-1/2" GR. 5
4	2	LW55	CYLINDER PIN
5	1	YPHR02010	HAIR PIN
6	1	TS105	3-1/4 X 8 CYLINDER
7	1	TS104	3 x 8 CYLINDER
8	4	T143	CYLINDER PIN
9	1	TS110	HYD. HOSE 1/2" X 99" -8 JIC FEMALE SWIVEL & 1/2 MP
10	1	TS107	HYD. HOSE 1/2" X 197" -8 JIC FEMALE SWIVEL & 1/2 MP
11	1	TS109	HYD. HOSE 1/2" X 94" -8 JIC FEMALE SWIVEL & -8 JIC FEMALE SWIVEL
12	1	TS111	HYD. HOSE 1/2" X 162" -8 JIC FEMALE & 1/2 MP
13	1	TS112	HYD. HOSE 1/2" X 56" -8 JIC FEMALE SWIVEL & -8 JIC MALE HYD. HOSE
14	1	TS113	1/2" X 120" -8 JIC MALE & 1/2 MP
15	1	TS70	HYD. HOSE 1/2" X 42" -8 JIC FEMALE SWIVEL & -8 JIC MALE
16	1	TS71	HYD. HOSE 1/2" X 52" -8 JIC FEMALE SWIVEL & -8 JIC MALE
17	2	TS116	HYDRAULIC LINE
18	3	TS135	-8 MALE O-RING TO -8 MALE JIC 90°
19	2	TS136	3/8" MALE PIPE TO -8 MALE JIC 90°
20	1	TS137	-8 MALE O-RING TO -8 MALE JIC
21	4	TFM38	-8 FEMALE JIC SWIVEL TO -8 MALE JIC 90°
22	1	TS139	-8 JIC SWIVEL BRANCH TEE
23	1	TS299	-8 MALE JIC TO 3/8" FEMALE PIPE
24	4	DWM205	QUICK COUPLER MALE
25	3	TS117	LINE CLAMP CAP
26	6	TS118	LINE CLAMP BLOCK
27	3	TFM91	DOUBLE STEEL LINE CLAMP
28	12	GM69	LINE CLAMP CAP
29	24	GM70	LINE CLAMP BLOCK
30	12	GM9	HOSE CLAMP 1/2" TWIN (COMPLETE)
31	1	TS197	ORIFICE .031
32	4	YPCT05010	COTTER PIN, 5/32" X 1-1/2"

NOTE: * MEANS NOT SHOWN

FIGURE 10
5126 TANDEM AXLES 3" SPINDLE

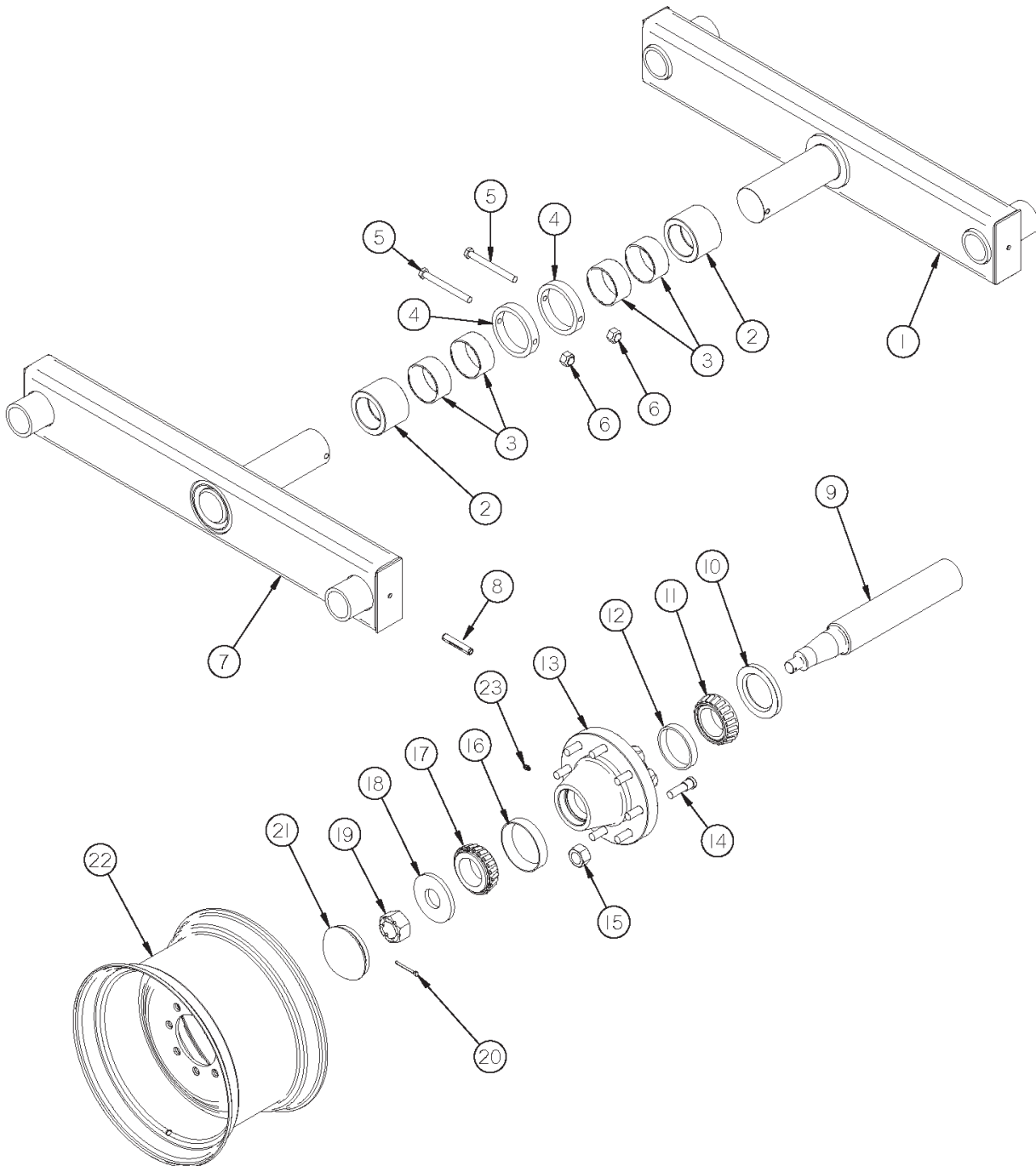

FIGURE 10

5126 TANDEM AXLES 3" SPINDLE

<u>ITEM</u>	<u>QTY</u>	<u>PART #</u>	<u>DESCRIPTION</u>
1	1	33SV36	TANDEM BEAM LH
2	2	70157	BUSHING, NYLATRON, 4.50" OD X 4.00" ID X 3.25"
3	4	70161	BUSHING, NYLATRON, 4.50" OD X 4.00" ID X 1.56"
4	2	16SV214	COLLAR FOR AXLE
5	2	YBHH16155	BOLT, 1/2" X 5" GR. 5
6	2	YNL16005	HEX NUT, TOP LOCK, 1/2"-13
7	1	33SV37	TANDEM BEAM RH
8	4	YPEX16020	EXPANSION PIN, 1/2" X 4"
9	4	54577	SPINDLE 3 X 19.563
10	4	54599	SEAL
11	4	54597	INNER BEARING
12	4	54593	INNER RACE
13	4	54564	HUB - 8 BOLT (COMPLETE)
14	32	YBSD20010	STUD BOLT, 5/8"-18 UNF X 2-1/2" (7/8" SHOULDER)"
15	32	YNWL20005	WHEEL NUT, 5/8"-18 UNF
16	4	54594	OUTER RACE
17	4	54598	OUTER BEARING
18	4	B4	WASHER
19	4	YNSL28005	HEX NUT, SLOTTED, 7/8"-14
20	4	YPCT05020	COTTER PIN, 5/32" X 1-3/4"
21	4	B2	HUB CAP
22	4	12V36	WHEEL 14 X 16.1
*	4	33SV105	WHEEL 16 X 16.1
*	4	16SV89	WHEEL 13.5 X 22.5
23	4	54595	GREASE ZERK, 1/8"-27 NPT

NOTE: * MEANS NOT SHOWN

FIGURE 11

OILER KIT

<u>ITEM</u>	<u>QTY</u>	<u>PART #</u>	<u>DESCRIPTION</u>
1	1	HGV63	RESERVOIR
2	1	S522	MANUAL HOLDER
3	1	HGV71	OIL TUBE
4	1	HGV66	FILLER HOSE
5	1	HGV82	PUMP (COMPLETE)
6	4	HGV86	STANDOFF
7	4	HGV87	FERRULE
8	4	HGV85	SLEEVE NUT
9	1	HGV68	PUMP MOUNT BRACKET
10	1	HGV77	EDGING
11	2	HGV69	BRUSH BRACKET LONG
12	2	TS98	OILER BRUSH BRACKET SINGLE
13	1	HGV70	BRACKET MOUNT
14	1	TS198	ORIFICE .015 (4XH7-S)
15	1	TS322	EXTRA LONG BRUSH BRACKET
16	1	TS196	OILER HANGER
*	1	HGV62	COMPLETE OILER KIT
17	1	HGV74	2" HOSE CLAMP
18	2	HGV75	1" HOSE CLAMP
19	1	HGV65	O-RING/JIC ELBOW
20	4	HGV67	BRUSH
21	11	YBHH08100	BOLT, 1/4" X 3/4" GR. 5
22	2	YBHH12135	BOLT, 3/8" X 3/4" GR. 5
23	1	YBHH16045	BOLT, 1/2" X 1-1/4" GR. 5
24	11	YWFL08005	WASHER, FLAT, 1/4" USS
25	1	YWFL16005	WASHER, FLAT, 1/2" USS
26	11	YWLO08005	WASHER, LOCK, 1/4"
27	2	YWLO12005	WASHER, LOCK, 3/8"
28	1	YWLO16005	WASHER, LOCK, 1/2"
29	11	YNHX08005	HEX NUT, 1/4"-20
30	2	YNHX12005	HEX NUT, 3/8"-16
31	5	YNHX16005	HEX NUT, 1/2"

NOTE: * MEANS NOT SHOWN

FIGURE 12
FRONT GREASE LINES

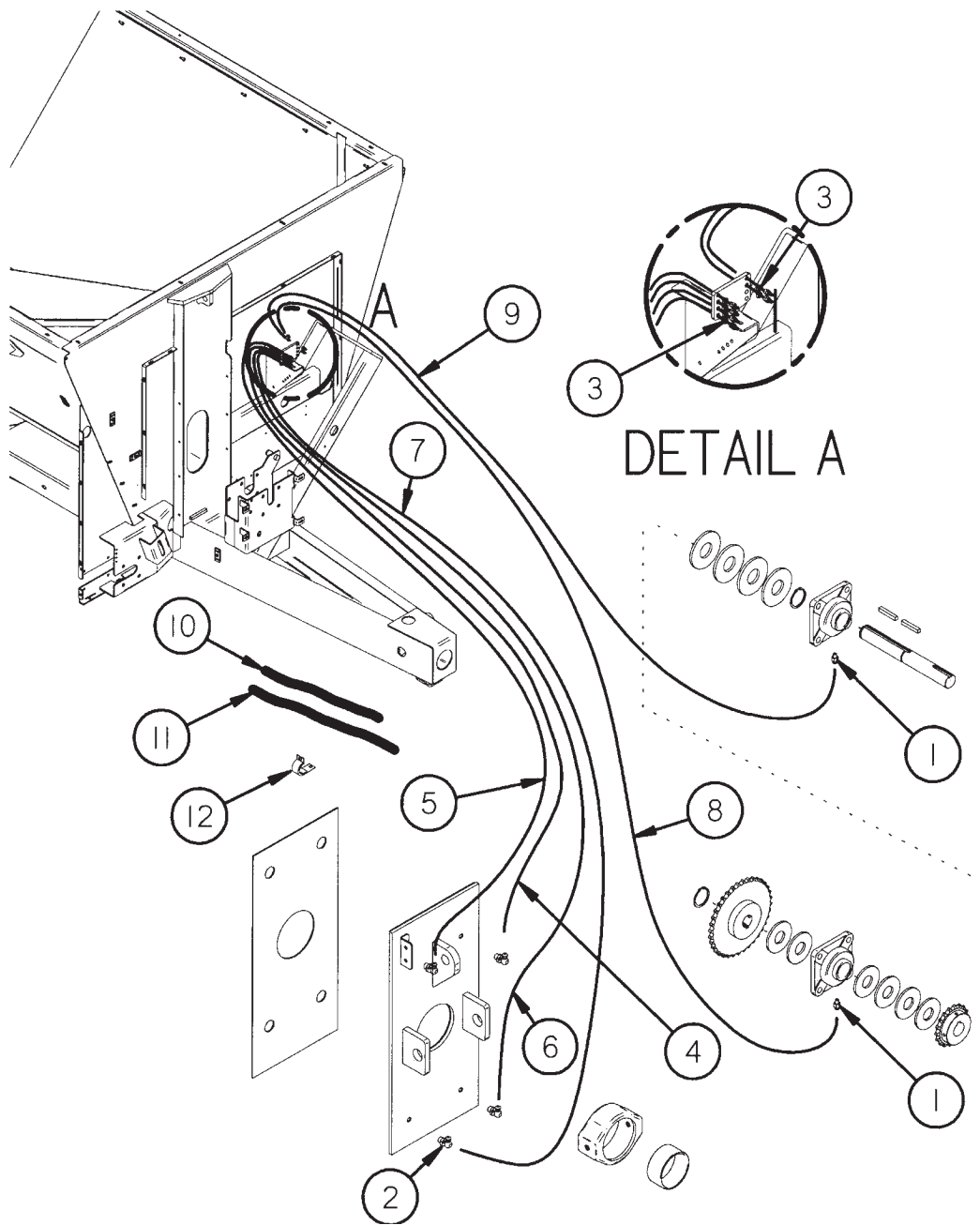

FIGURE 12

FRONT GREASE LINES

<u>ITEM</u>	<u>QTY</u>	<u>PART #</u>	<u>DESCRIPTION</u>
1	2	TS323	1/4"-28 TO 1/8" PIPE ADAPTER
2	4	GM30	1/8" 90° GREASE LINE ADAPTER
3	6	YNML99005	M10-1.0 JAM NUT A2 SS
4	1	TS119	GREASE LINE - 23"
5	1	TS120	GREASE LINE - 29.5"
6	1	TS121	GREASE LINE - 38.5"
7	1	TS122	GREASE LINE - 45.5"
8	1	TS123	GREASE LINE - 60"
9	1	TS124	GREASE LINE - 63.75"
10	1	TS246	SPLIT LOOM 3/4" X 18"
11	1	TS305	SPLIT LOOM 3/4" X 24"
12	1	HGV162	1/2" RUBBER WIRE HOLDER

FIGURE 13
LIGHTING

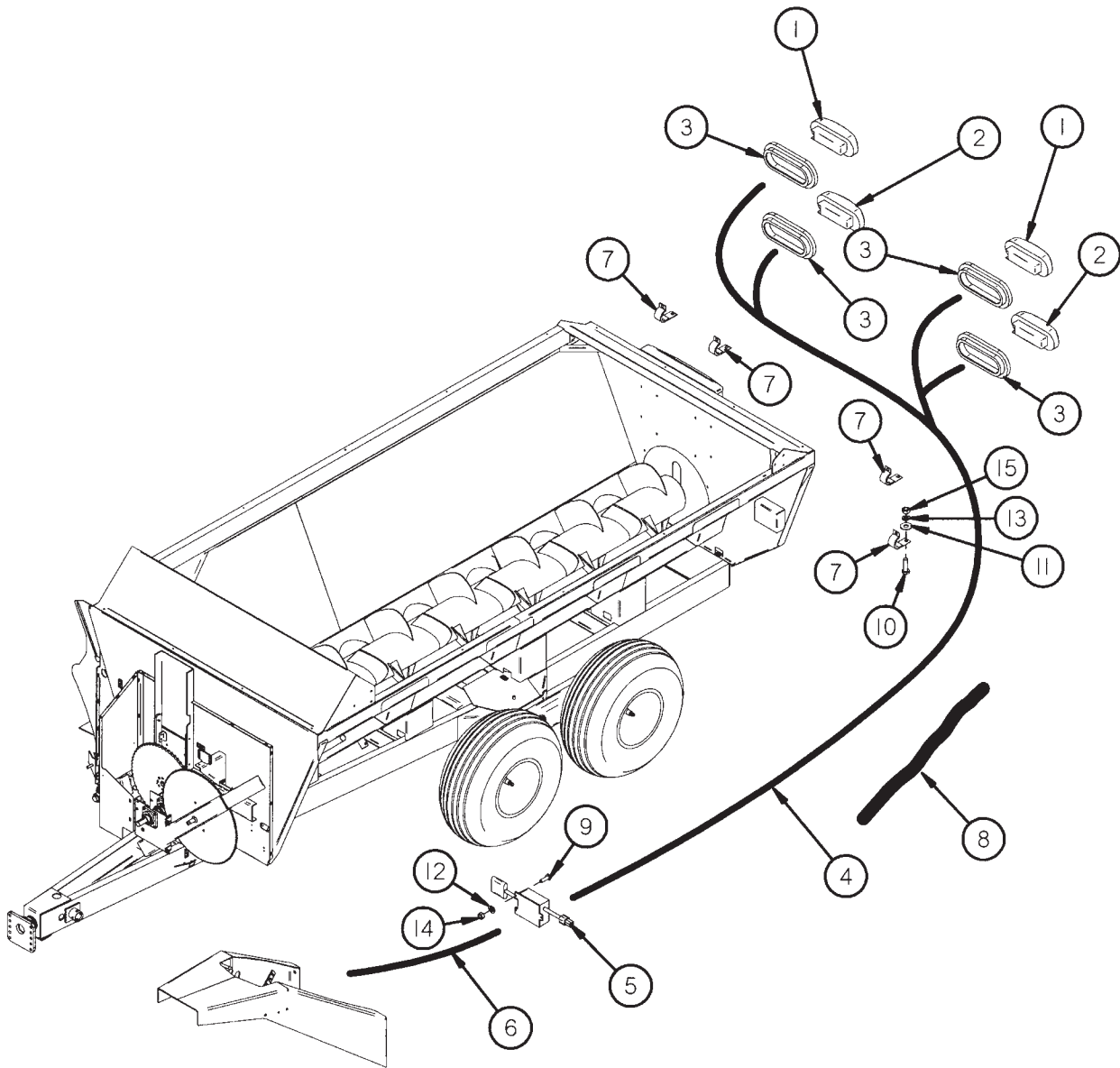

FIGURE 13

LIGHTING

<u>ITEM</u>	<u>QTY</u>	<u>PART #</u>	<u>DESCRIPTION</u>
1	2	S309	YELLOW HAZARD LIGHT
2	2	S310	RED TAIL LIGHT
3	4	S308	RUBBER LIGHT MOUNT
4	1	56N155	TAIL LIGHT LOOM
5	1	69908	MODULE, CONTROL, BLINKER
6	1	TS317	HARNESS MODULE TO TRACTOR
7	4	HGV162	1/2" RUBBER WIRE HOLDER
8	1	TS129	SPIRAL WRAP, 30"
9	3	YSPP64010	#10-32 X 1" PHILLIPS HEAD MACHINE SCREW
10	4	YBHH10105	BOLT, 5/16" X 3/4" GR. 5
11	4	YWFL10005	WASHER, FLAT, 5/16"
12	3	YWLO08005	WASHER, LOCK, 1/4"
13	4	YWLO10005	WASHER, LOCK, 5/16"
14	3	YNHX64005	HEX NUT, #10-32
15	4	YNHX10005	HEX NUT, 5/16"

FIGURE 14

AUGER

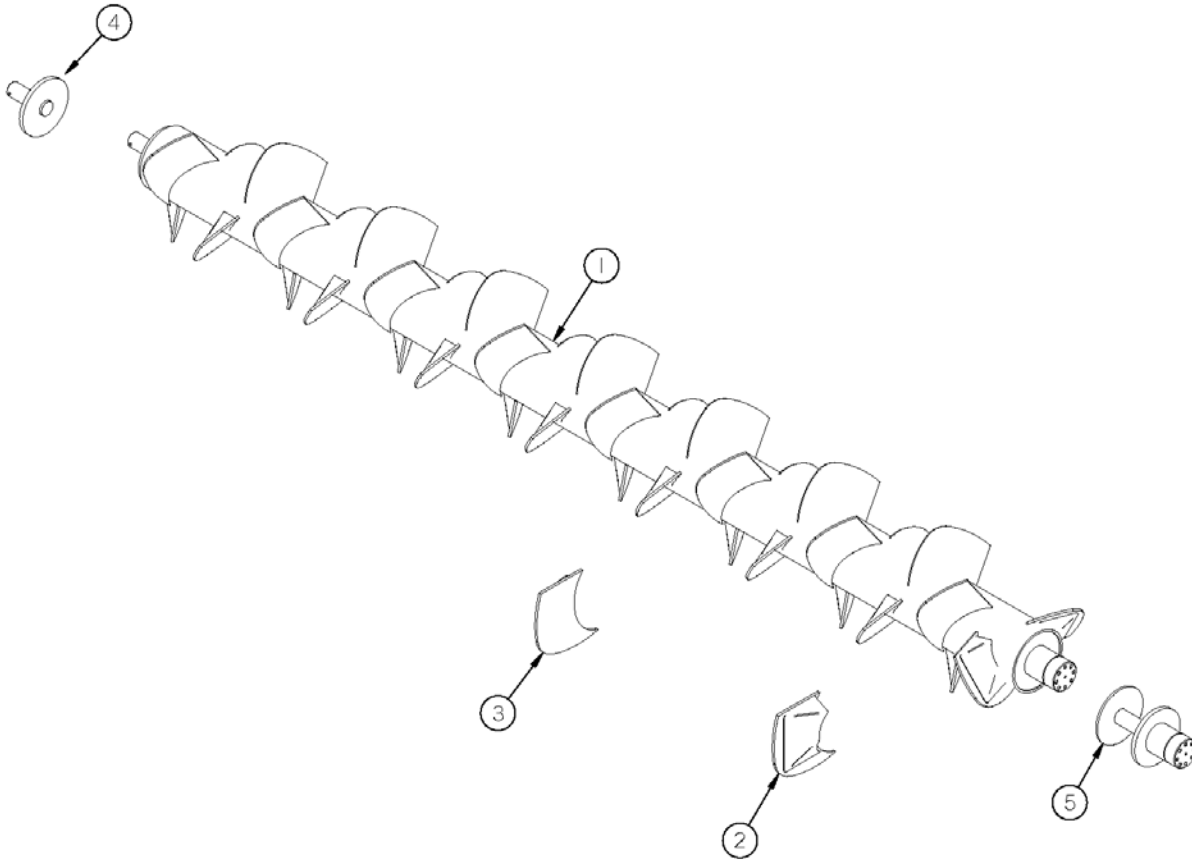

<u>ITEM</u>	<u>QTY</u>	<u>PART #</u>	<u>DESCRIPTION</u>
1	1	TS1	AUGER
2	2	TS125	AUGER PADDLE FRONT
3	37	TS126	AUGER PADDLE REAR
4	1	TS127	AUGER REARASSEMBLY
5	1	TS128	AUGER INPUT ASSEMBLY

FIGURE 15

AUGER FRONT/REAR HYDRAULIC CYLINDER

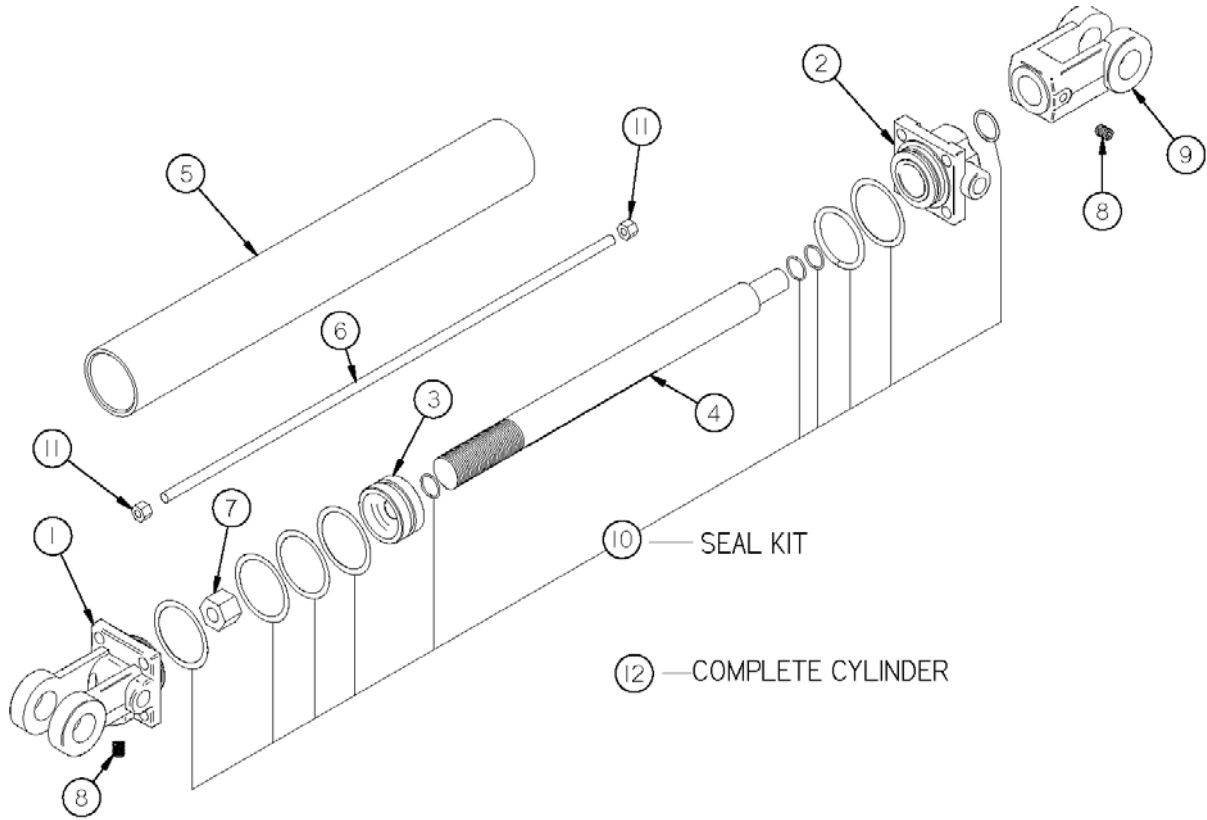

ITEM	QTY	3" BORE	3-1/4" BORE	DESCRIPTION
1	1	TS160	TS176	BASE (3/4-16 SAE PORT)
2	1	TS158	TS174	HEAD (3/4-16 SAE PORT)
3	1	TS159	TS175	PISTON NUT
4	1	TS156	TS172	ROD
5	1	TS157	TS173	TUBE
6	4	TS153	TS171	TIE ROD
7	1	TS145	TS166	PISTON NUT
8	1	TS152	"	PLUG ASSY (3/4-16 SAE)
9	1	TS155	"	CLEVIS ASSEMBLY
10	1	TS163	TS177	SEAL KIT
11	8	TS144	TS165	TIE ROD NUT
12	1	TS104	—	3 x 8 CYLINDER
*	1	—	TS105	3-1/4 X 8 CYLINDER

NOTE: " MEANS SAME AS PREVIOUS MODEL
— MEANS NOT USED ON THIS MODEL

FIGURE 16

EXPELLER DOOR HYDRAULIC CYLINDER 2" x 16"

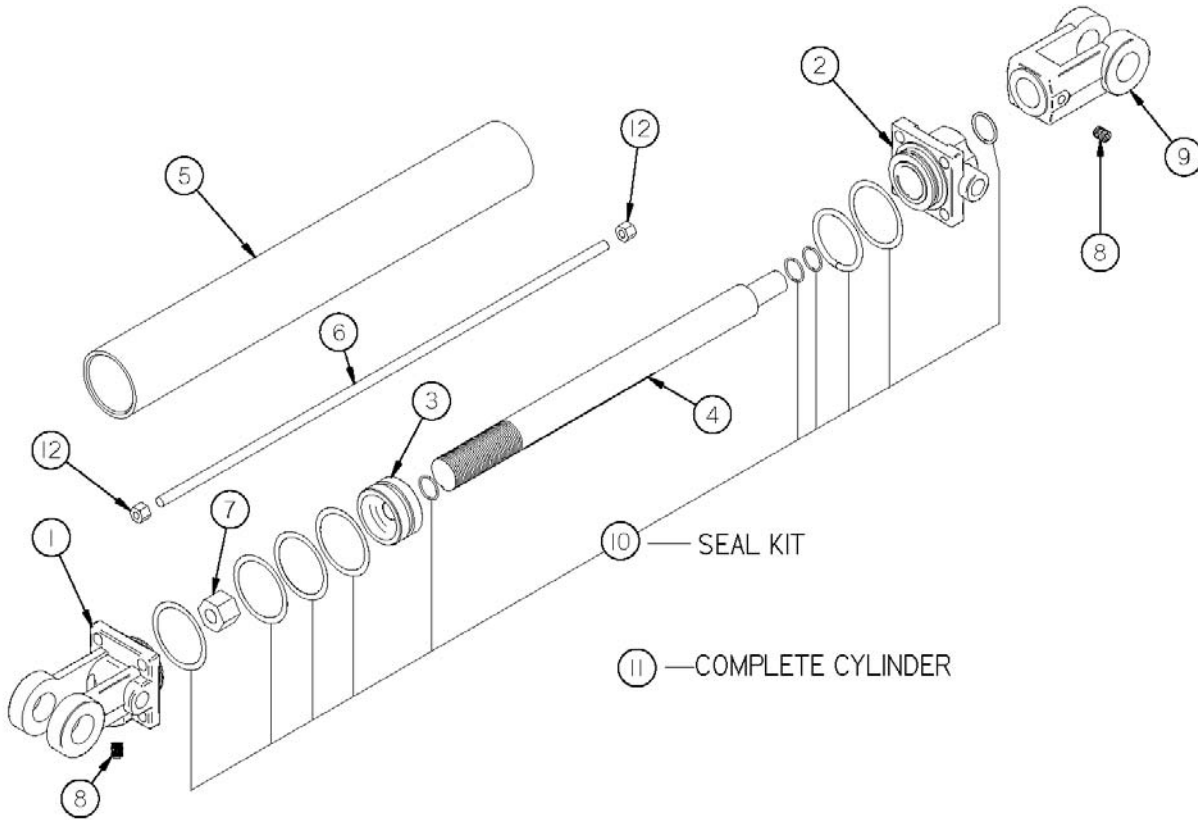

ITEM	QTY	PART #	DESCRIPTION
1	1	23N142A	CLEVIS CAP
2	1	23N143	ROD CAP
*	1	56174	ROD CAP
3	1	23N144	PISTON
*	1	56180	PISTON
4	1	23N145A	ROD
5	1	23N146	CYLINDER TUBE
6	4	23N147	TIE ROD
7	1	23N148	PISTON NUT
8	2	23N149	PLUG
9	1	23N150A	ROD CLEVIS
10	1	23N151	SEAL KIT
*	1	56187	SEAL KIT
11	1	23N111A	COMPLETE HYD. CYL.
*	1	56015	COMPLETE HYD. CYL.
12	8	YNHX12005	HEX NUT, 3/8"-16

NOTE: * MEANS NOT SHOWN

FIGURE 17

SCALE

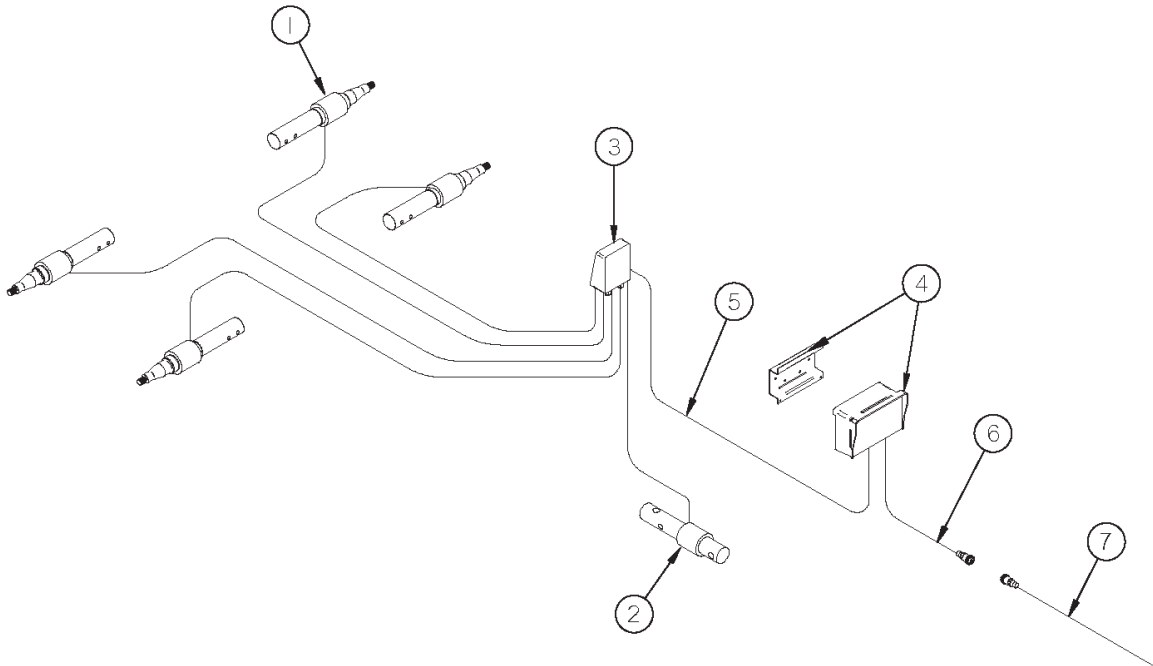

<u>ITEM</u>	<u>QTY</u>	<u>PART #</u>	<u>DESCRIPTION</u>
1	4	TS333	SPINDLE LOAD CELL
2	1	GM403	HITCH LOAD CELL
3	1	TS83	JUNCTION BOX
4	1	GM408	BRKT IND MTG 840459
*	1	TS337	SCALE DISPLAY W/GPS (OPTIONAL)
5	1	TS338	JUNCTION BOX CORD
6	1	TS385	POWER CORD
7	1	16SV269	TRACTOR POWER CORD
8	1	GM408	SCALE HANGER BRACKET

NOTE: * MEANS NOT SHOWN

FIGURE 18

OPTIONAL PTO (540 RPM)

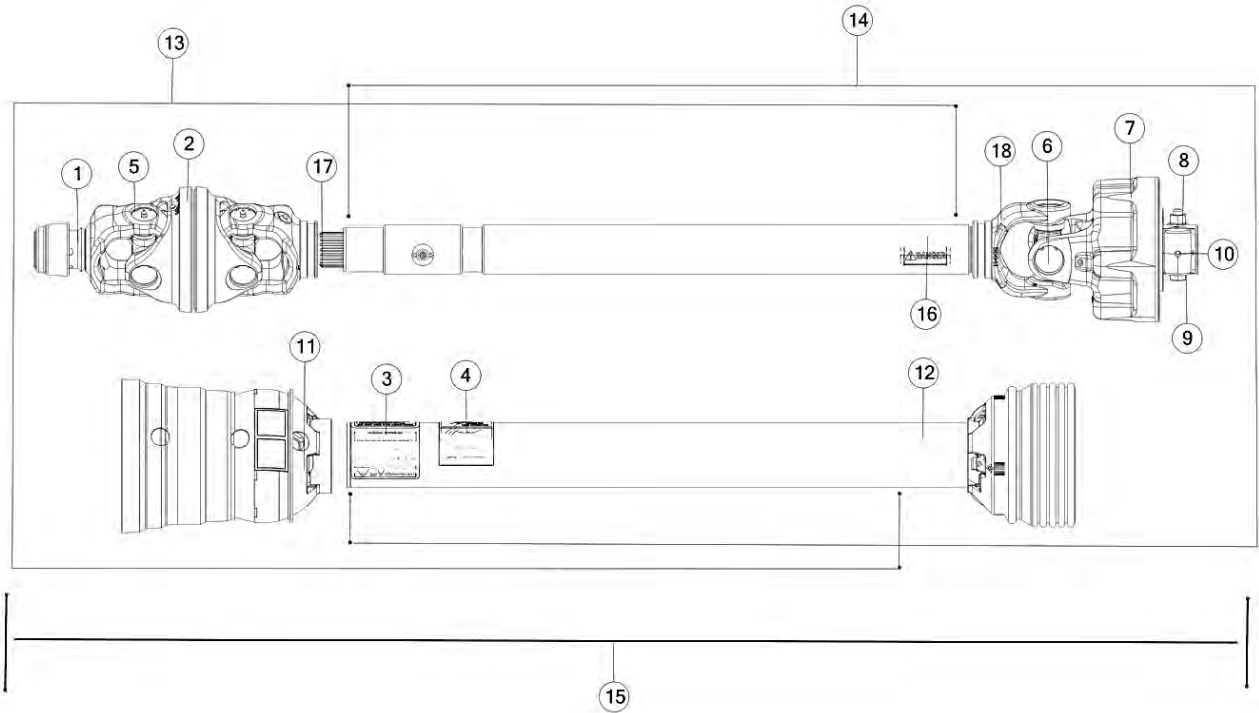

ITEM	540 RPM	DESCRIPTION
1	56655	PTO, YOKE, TUBE & SLIP SLEEVE, 540 RPM
2	56509	CENTER HOUSING PTO PART
3	1494L	DECAL-DANGER ROTATING DRIVE
4	16SV286	SAFETY SIGN (C.V INSTRUCTIONAL DECAL)
5	56656	AB8 / AW24 / CAT 6 80 EBL CROSS KIT
6	63405	CROSS KIT, 55E
7	70565	PTO, CLUTCH 55 AUTO, 23600 IN-LBF MIN.
8	YNFG16010	HEX NUT, FLANGED, TOP LOCK, 1/2, GR G, Z
9	YBFB16040	BOLT, FLANGE, 1/2-13 X 3.00, GR. 8
10	YSKP12030	SET SCREW, SOCKET, KNURLED CUP PT, 3/8-16 X 3/8 W/NYL PTCH
11	57973	OUTER GUARD
12	70597	SHLD, PTO SHAFT OUTER GUARD
13	57967	JOINT & SHAFT HALF ASM. W/ GUARD
14	70591	PTO, JOINT & TUBE HALF, GUARDED, 540 RPM
15	70647	PTO, 540 RPM, 28800 IN-LBF, AUTO
16	16SV388	SAFETY SIGN
17	57971	WWCV YOKE & SHAFT (1.69-20)
18	70598	PTO, YOKE, TUBE & SLIP SLEEVE, 540 RPM
*	57972	GUARD REPAIR KIT
*	16SV274	SAFETY SLIDE LOCK REPAIR KIT
*	S402	ADMA SAFETY MANUAL

* MEANS NOT SHOWN

FIGURE 19

PTO (1000 RPM)

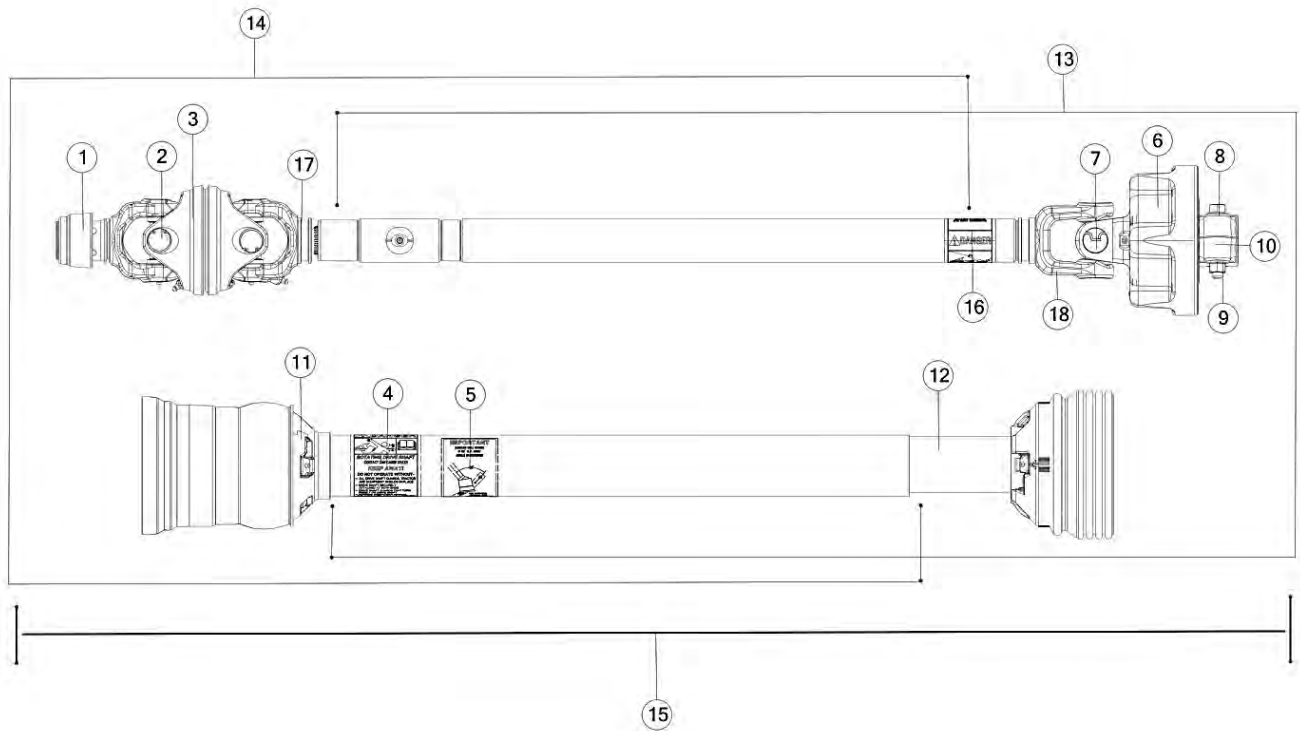

ITEM	1000 RPM	DESCRIPTION
1	63389	YOKE, 4 80 WWCV, AUTO-LOC
2	63784	CROSS KIT, AB6/AW22/480 EBL
3	TS180	CENTER HOUSING
4	1494L	DECAL-DANGER ROTATING DRIVE
5	16SV286	SAFETY SIGN (C.V INSTRUCTIONAL DECAL)
6	70563	PTO, CLUTCH 35 AUTOMATIC, 15900 IN-LBF MIN.
7	61370	CROSS KIT, 35E
8	YBFB16040	BOLT, FLANGE, 1/2-13 X 3.00, GR. 8
9	YNFG16010	HEX NUT, FLANGED, TOP LOCK, 1/2, GR G, Z
10	YSKP12030	SET SCREW, SOCKET, KNURLED CUP PT, 3/8-16 X 3/8 W/NYL PTCH
11	TS182	OUTER GUARD
12	70585	SHLD, PTO SHAFT INNER GUARD
13	70581	PTO, JOINT & TUBE HALF, GUARDED, 1000 RPM
14	63790	JOINT & SHAFT HALF, GUARDED
15	70329	PTO, 1000 RPM, 19500 IN-LBF, AUTO
16	16SV388	SAFETY SIGN
17	TS181	PTO, WWCV YOKE & SHAFT (1.31-20 SPLN), 1000 RPM
18	70586	PTO, YOKE, TUBE & SLIP SLEEVE, 1000 RPM
*	16SV383	GUARD REPAIR KIT
*	16SV274	SAFETY SLIDE LOCK REPAIR KIT
*	S402	ADMA SAFETY MANUAL

* MEANS NOT SHOWN

H&S MFG. CO.

products approved

for the

FEMA

SEAL OF QUALITY

