

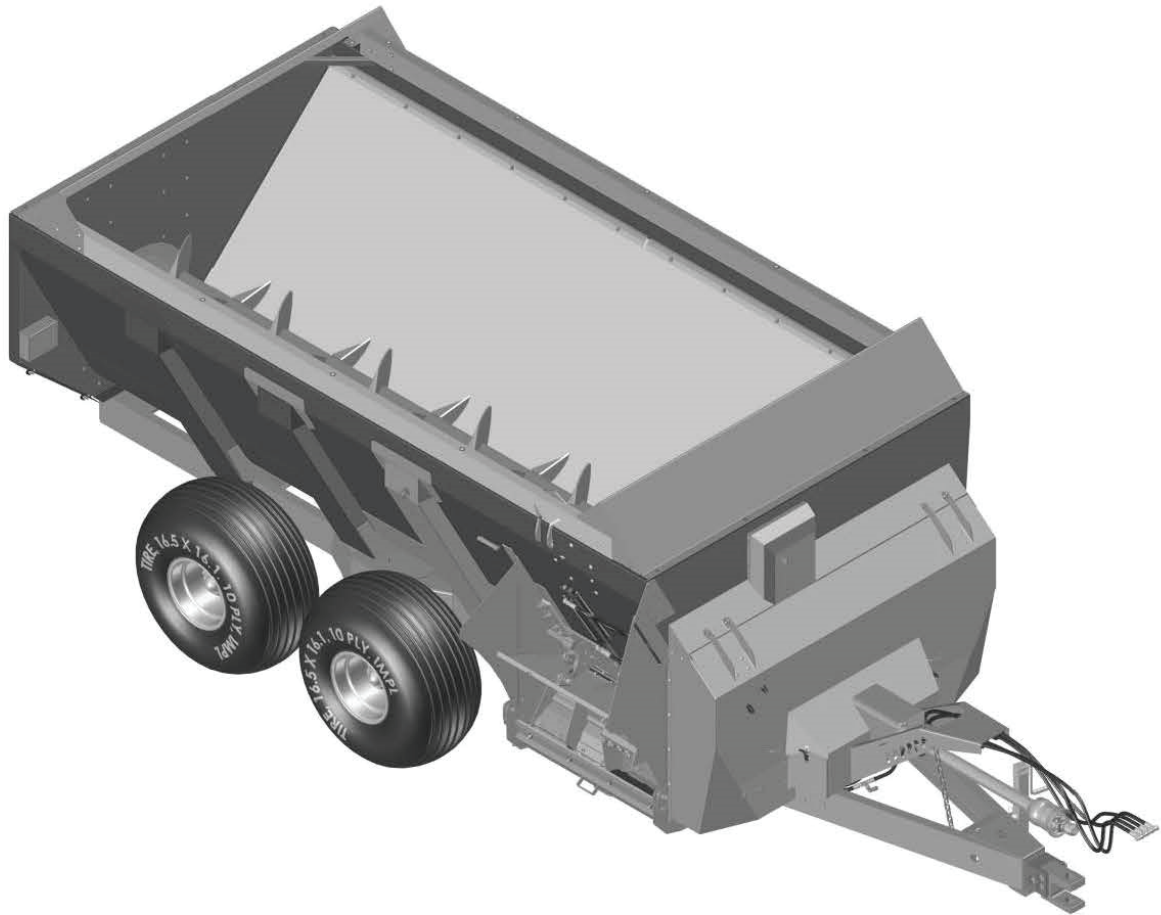

5234 TOP SHOT MANURE SPREADER



Revision #04

Starting Ser. #022TS34007

HSMFGC0320

PART#72827

Manufactured By
H&S MANUFACTURING CO., INC.
2608 S. HUME AVE. MARSHFIELD, WI 54449
(715) 387-3414 FAX (715) 384-8736

CONTENTS

Instructions for Ordering Parts - About Improvements	1
Figure 1 - Auger/Liner/Slides/Hitch	2-5
Figure 2 - Auger/Expeller Drive	6-9
Figure 3 - Expeller/Discharge Gate/Bearings	10-11
Figure 4 - Expeller/Discharge Gate/Door	12-13
Figure 5 - Expeller/Discharge Gate/Pan	14-15
Figure 6 - Guards/Shields	16-17
Figure 7 - Splash Guards/Rails	18-19
Figure 8 - Hydraulics	20-21
Figure 9 - Tandem Axles	22-23
Figure 10 - Optional Tandem Axles	24-25
Figure 11 - Oiler Kit	26-27
Figure 12 - Front Grease Lines	28-29
Figure 13 - Lighting	30-31
Figure 14 - Auger	32-33
Figure 15 - Gear Box	34-35
Figure 16 - Auger Front & Rear Hydraulic Cylinder	36-37
Figure 17 - Expeller Door Hydraulic Cylinder	38-39
Figure 18 - PTO (1000Rpm 1-3/8)	40-41
Figure 19 - PTO (1000Rpm1-3/4)	42-43
Figure 20 - Scale	44-45
Figure 21 - Cover Components	46-47
Figure 22 - Cover Hydraulics	48-49
Figure 23 - Cover Seal	50-51
Figure 24 - Optional Tire & Wheel	52-53
Figure 25 - Optional Tire & Wheel Heavy Axles	54-55
Figure 26 - Discharge Deflector Hydraulic	56-57
Figure 27 - Electric Valve for Discharge Deflector Hydraulic Cylinder	58-59
Parts Notes	60

INSTRUCTIONS FOR ORDERING PARTS

All service parts should be ordered through your authorized H&S dealer. He will be able to give you faster service if you will provide them with the following:

1. Model & Serial Number - Both can be located on the front main frame, below the PTO.
2. All references to left or right apply to the machine as viewed from the rear.
3. Parts should not be ordered from illustration only. Please order complete part number.
4. If your dealer has to order parts - give shipping instructions:

VIA truck - large pieces (please specify local truck lines)

VIA United Parcel Service (include full address)

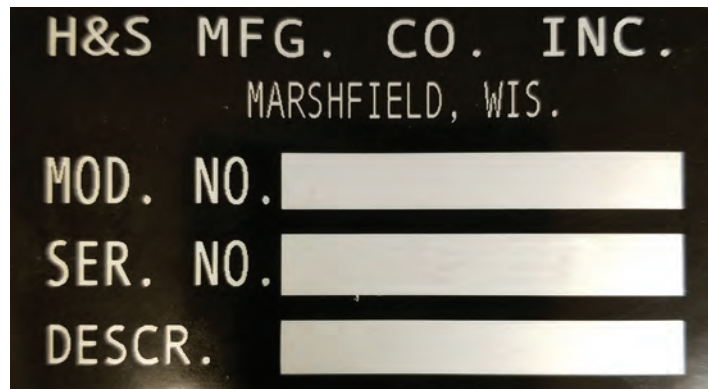

PLEASE RECORD NUMBERS FOR YOUR UNIT FOR QUICK REFERENCE

ABOUT IMPROVEMENTS

H&S IS CONTINUALLY STRIVING TO IMPROVE IT'S PRODUCTS

We must therefore, reserve the right to make improvements or changes whenever it becomes practical to do so, without incurring any obligation to make changes or additions to the equipment previously sold.

FIGURE 1

AUGER/LINER/SLIDES/HITCH

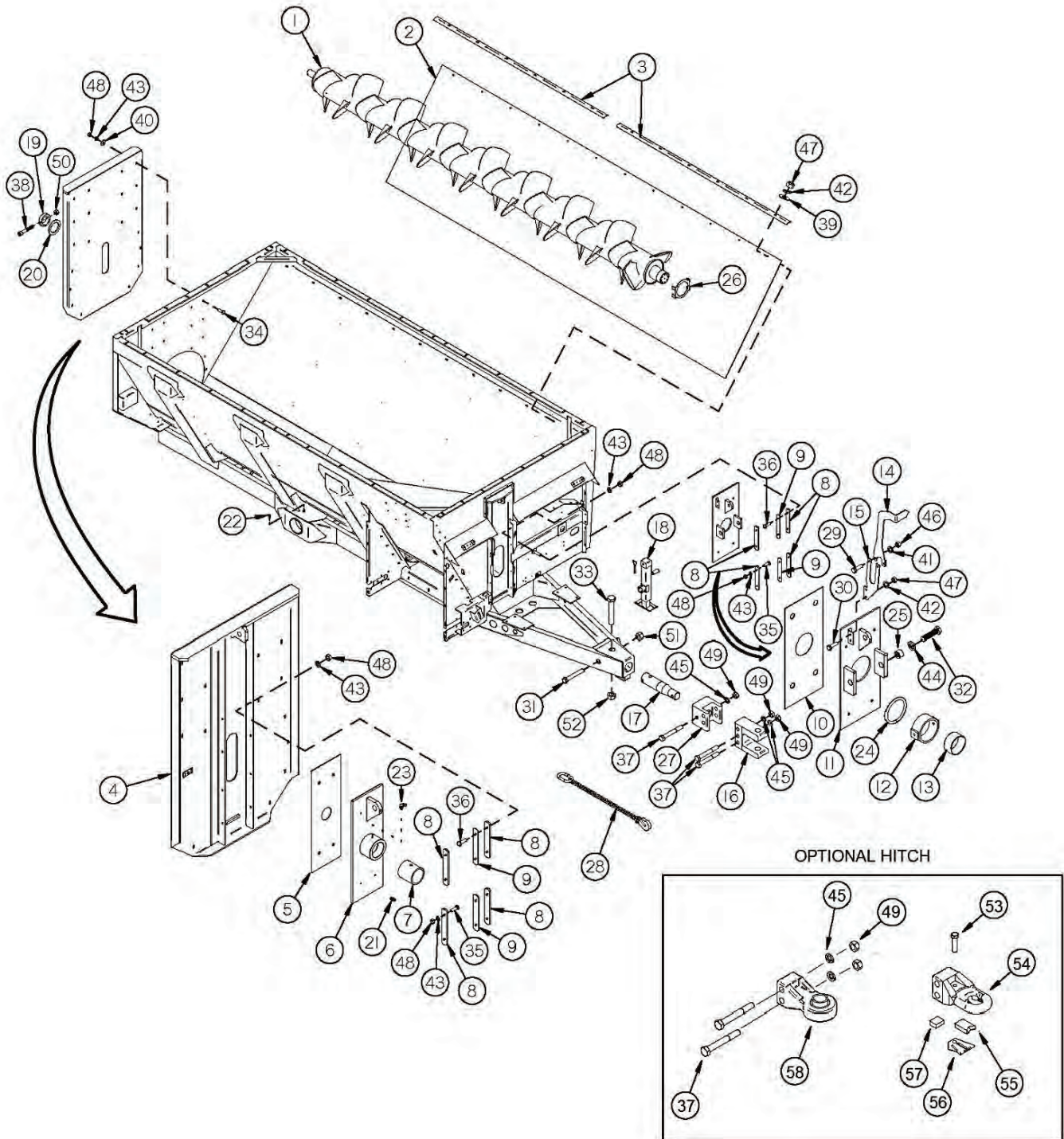

FIGURE 1

AUGER/LINER/SLIDES/HITCH

<u>ITEM</u>	<u>QTY</u>	<u>PART#</u>	<u>DESCRIPTION</u>
1	1	TS200	AUGER
2	1	TS201	TUB SIDE POLY
3	1	TS4	POLY TOP HOLD DOWN
4	1	TS202	PANEL BACK
5	1	TS7	SLIDER POLY BACK
6	1	TS309	SLIDER BACK
7	1	TS9	AUGER BUSHING REAR
8	8	TS10	SLIDER GUIDE
9	6	TS308	SLIDER GUIDE THIN
10	1	TS203	POLY SLIDE FRONT
11	1	TS204	SLIDE PLATE FRONT
12	1	TS205	TRUNNION HOUSING
13	1	TS206	AUGER BEARING FRONT
*	1	TS400	TRUNNION HOUSING W/BEARING
14	1	TS207	AUGER INDICATOR TOP
15	1	TS208	AUGER INDICATOR BOTTOM
16	1	56310	HEAVY CLEVIS
17	1	TS210	HITCH BAR STRAIGHT
18	1	TS306	JACK, SIDE WIND, 7000LBS
19	1	TS19	AUGER BACK COLLAR
20	A/R	TS227	SPACER 2-17/32 (THICK)
*	A/R	TS28	SPACER 2-17/32 (THIN)
21	1	G89	STRAIGHT ZERK, 1/4 X 90
22	1	DWM133	GREASE ZERK 45 DEGREE, 1/8
*	1	16SV440	GREASE ZERK, 1/8
23	1	RG51	GREASE ZERK 90 DEGREE
24	1	TS229	RUBBER RING, 6
25	3	TS230	BUSHING, 3/4 X 7/8
26	1	TS320	WEAR PLATE, 6 INCH
27	1	APX3HF41	HITCH ADAPTER
28	1	SC60000	SAFETY CHAIN 60000# (OPTIONAL)
29	1	YBHH08100	BOLT HEX, 1/4 X 3/4 G5
30	1	YBHH10105	BOLT HEX, 5/16 X 3/4 G5
31	1	YBHH20101	BOLT HEX, 5/8 X 6 G8
32	1	YBHH24018	BOLT HEX, YELLOW ZINC FINISH, 3/4 X 2 G8
33	2	YBHH32026	BOLT HEX, 1 X 6 G8
34	20	YBCR12010	BOLT CARRIAGE, 3/8 X 1 G5
35	8	YBCR12020	BOLT CARRIAGE, 3/8 X 1-1/4 G5
36	8	YBCR12015	BOLT CARRIAGE, 3/8 X 1-1/2 G5
37	5	YBHH32024	BOLT HEX, 1 X 7-1/2 G8
38	1	YSHS12018	SCREW SOCKET HEAD CAP, 3/8 X 4
39	12	YWFL10005	WASHER FLAT, 5/16
40	20	YWFL12005	WASHER FLAT, 3/8

***MEANS NOT SHOWN
A/R MEANS AS REQUIRED**

FIGURE 1 AUGER/LINER/SLIDES/HITCH

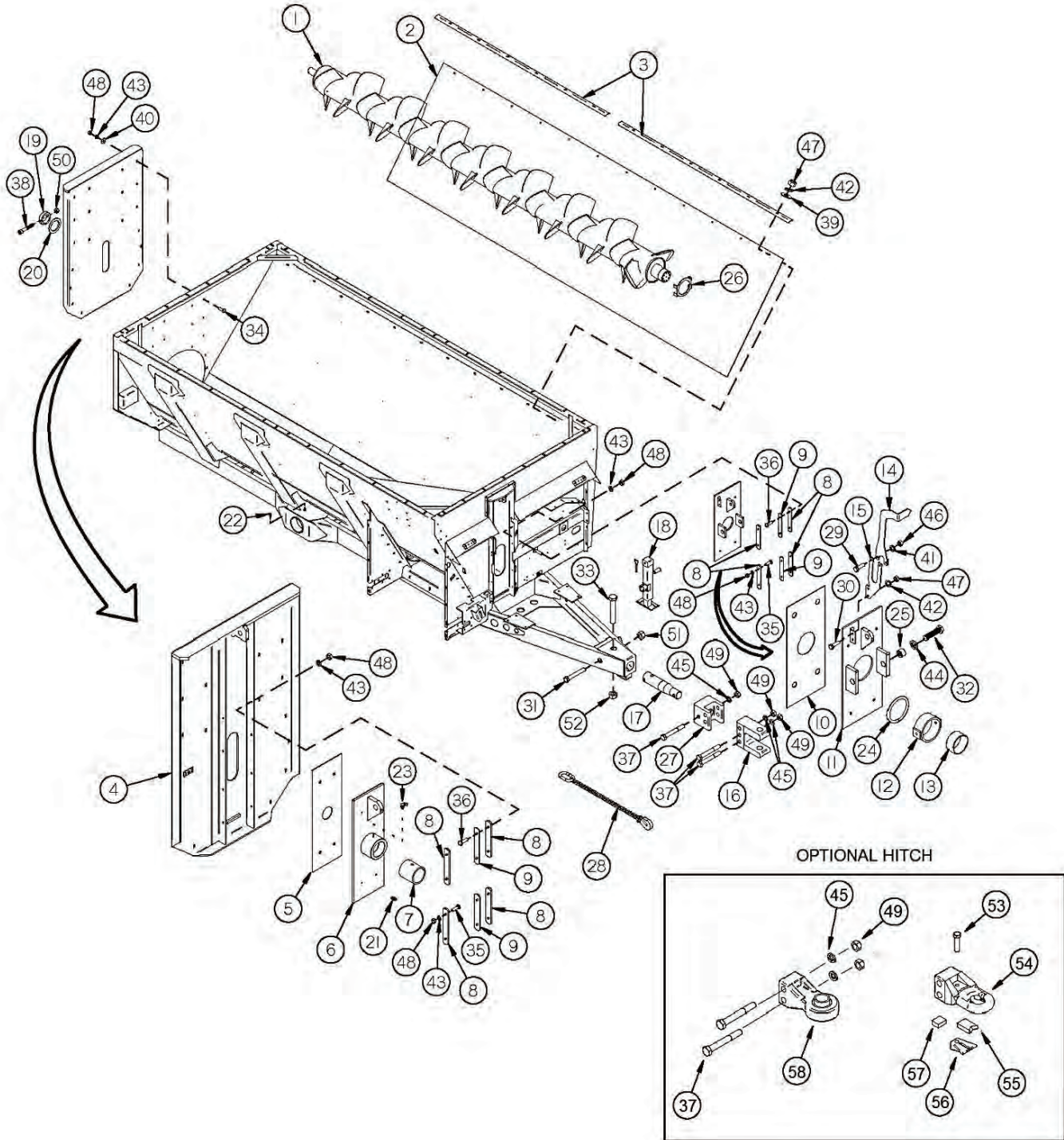

FIGURE 1
AUGER/LINER/SLIDES/HITCH

<u>ITEM</u>	<u>QTY</u>	<u>PART#</u>	<u>DESCRIPTION</u>
41	2	YWLO08005	WASHER LOCK, 1/4
42	14	YWLO10005	WASHER LOCK, 5/16
43	36	YWLO12005	WASHER LOCK, 3/8
44	2	YWLO24005	WASHER LOCK, 3/4
45	5	YWLO32005	WASHER LOCK, 1
46	2	YNHX08005	NUT HEX, 1/4
47	14	YNHX10005	NUT HEX, 5/16
48	36	YNHX12005	NUT HEX, 3/8
49	5	YNHX32015	NUT HEX, 1 G8
50	1	YNL12005	NUT HEX, TOP LOCK, 3/8
51	1	YNRL20005	NUT HEX, REVERSIBLE-SIDE LOCK, 5/8
52	1	YNRL32005	NUT HEX, REVERSIBLE-SIDE LOCK, 1
53	1	YBHH24051	BOLT HEX, 3/4 X 3 G5
54	1	58557	BASE, PERFECT HITCH
55	1	58558	V BLOCK
56	1	58559	PLATE, TOP
57	1	58554	CUSHION
58	1	58290	ARTICULATING HITCH

FIGURE 2 **AUGER/EXPELLER DRIVE**

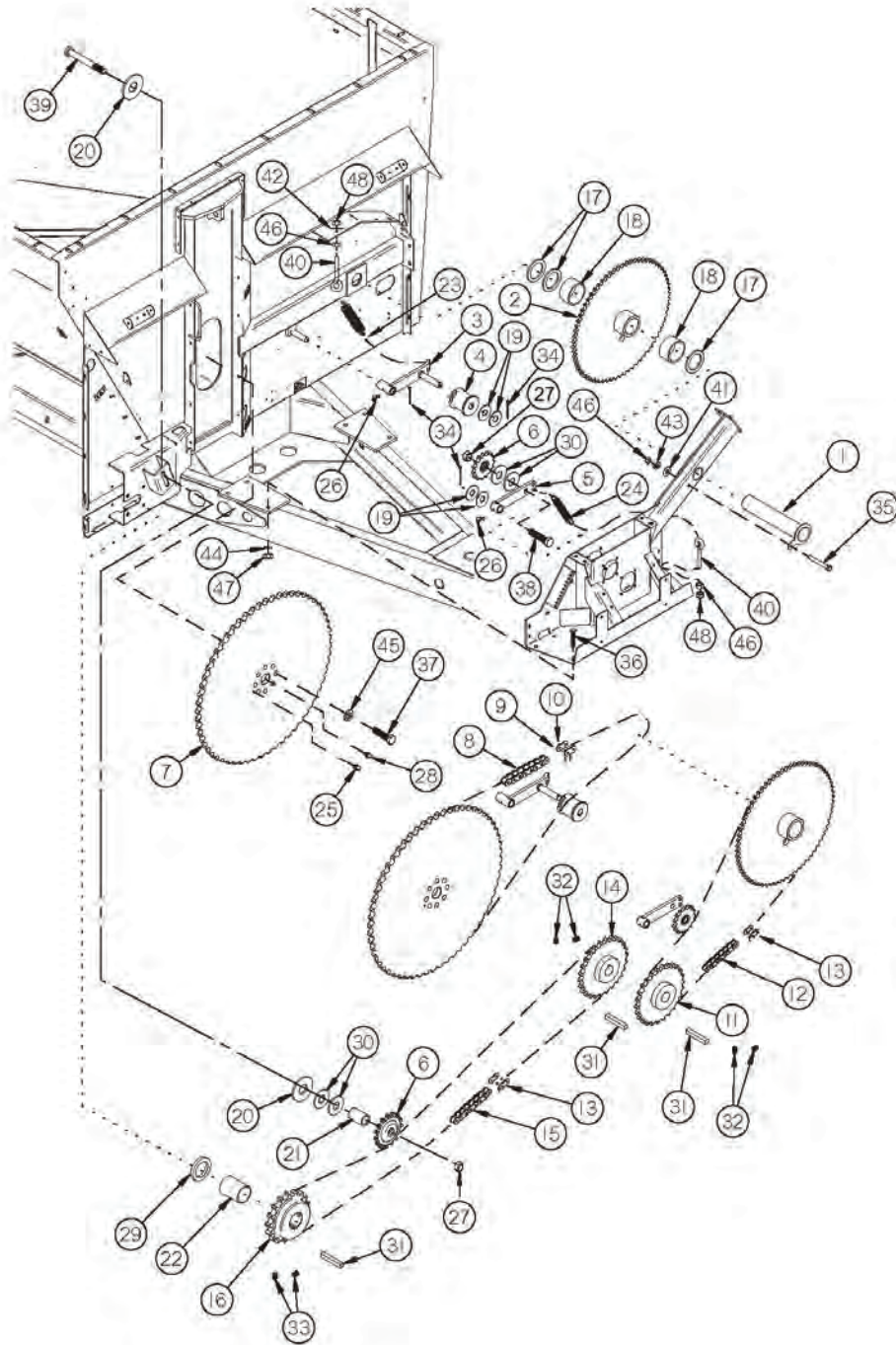

FIGURE 2

AUGER/EXPELLER DRIVE

<u>ITEM</u>	<u>QTY</u>	<u>PART#</u>	<u>DESCRIPTION</u>
1	1	TS211	COUNTER SHAFT
2	1	TS212	COUNTER SHAFT REDUCTION
3	1	TS213	AUGER CHAIN TENSIONER
4	1	TS25	ROLLER IDLER
5	1	TS214	CHAIN TENSIONER
6	2	16SV328	SPROCKET W/SNAP RING AND BEARING
7	1	TS217	SPROCKET
8	1	TS218	ROLLER CHAIN (#140HE)
9	1	TS219	OFFSET LINK (#140HE)
10	1	TS220	CONNECTOR LINK (#140HE)
11	1	TS221	DRIVE SPROCKET, #80X14T (STANDARD, FACTORY)
*	1	TS372	DRIVE SPROCKET, #80X12T (OPTIONAL, FIELD)
*	1	TS373	DRIVE SPROCKET, #80X15T (OPTIONAL, FIELD)
*	1	TS224	DRIVE SPROCKET, #80X16T (OPTIONAL, FIELD)
12	1	TS222	ROLLER CHAIN, #80HEX98 (14T & 15T SPRCKTS,FACTORY)
*	1	TS375	ROLLER CHAIN, #80HEX97 (12T SPROCKET, FIELD)
*	1	TS376	ROLLER CHAIN, #80HEX99 (16T SPROCKET, FIELD)
13	2	TS223	CONNECTOR LINK, (#80HE)
14	1	TS224	SPROCKET, #80X16T (STANDARD, FACTORY)
*	1	TS372	SPROCKET, #80X12T (OPTIONAL, FIELD)
*	1	TS221	SPROCKET, #80X14T (OPTIONAL, FIELD)
15	1	TS225	ROLLER CHAIN, #80HE X 84 (16T SPROCKET, FACTORY)
*	1	TS379	ROLLER CHAIN, #80HE X 82 (12T SPROCKET, FIELD)
*	1	TS380	ROLLER CHAIN, #80HE X 83 (14T SPROCKET, FIELD)
16	1	TS226	SPROCKET, 80B17
17	A/R	TS227	SPACER, 2-17/32 (THICK)
*	A/R	TS28	SPACER, 2-17/32 (THIN)
18	2	73576	BRONZE BUSHING, 2-1/2 X 3 X 3
19	4	S345	SPACER, 1
20	2	16SV376	SPACER
21	3	TS230	TRUNION PIVOT BUSHING, 3/4 X 7/8 X 1-1/4
22	1	TS231	SPACER
23	1	BFR138	SPRING
24	1	10R14	SPRING
25	3	G89	STRAIGHT ZERK, 1/4 X 90
26	2	RG51	GREASE ZERK, 1/4 - 28 90 DEGREE
27	2	YNRL24005	NUT HEX, REVERSIBLE-SIDE LOCK, 3/4
28	1	BFR28	GREASE ZERK, 1/8
29	A/R	S36	SHIM, 3/16
*	A/R	S409	SHIM, 1/8
30	4	T73	WASHER
31	3	G139	SQUARE KEY, 3/8 X 1-1/2
32	4	YSKP12025	SCREW SET SOCKET, KNURLED CUP PT, 3/8 X 3/8
33	2	YSKP12010	SCREW SET SOCKET, KNURLED CUP PT, 3/8 X 1/2

***MEANS NOT SHOWN**

A/R MEANS AS REQUIRED

FIGURE 2 **AUGER/EXPELLER DRIVE**

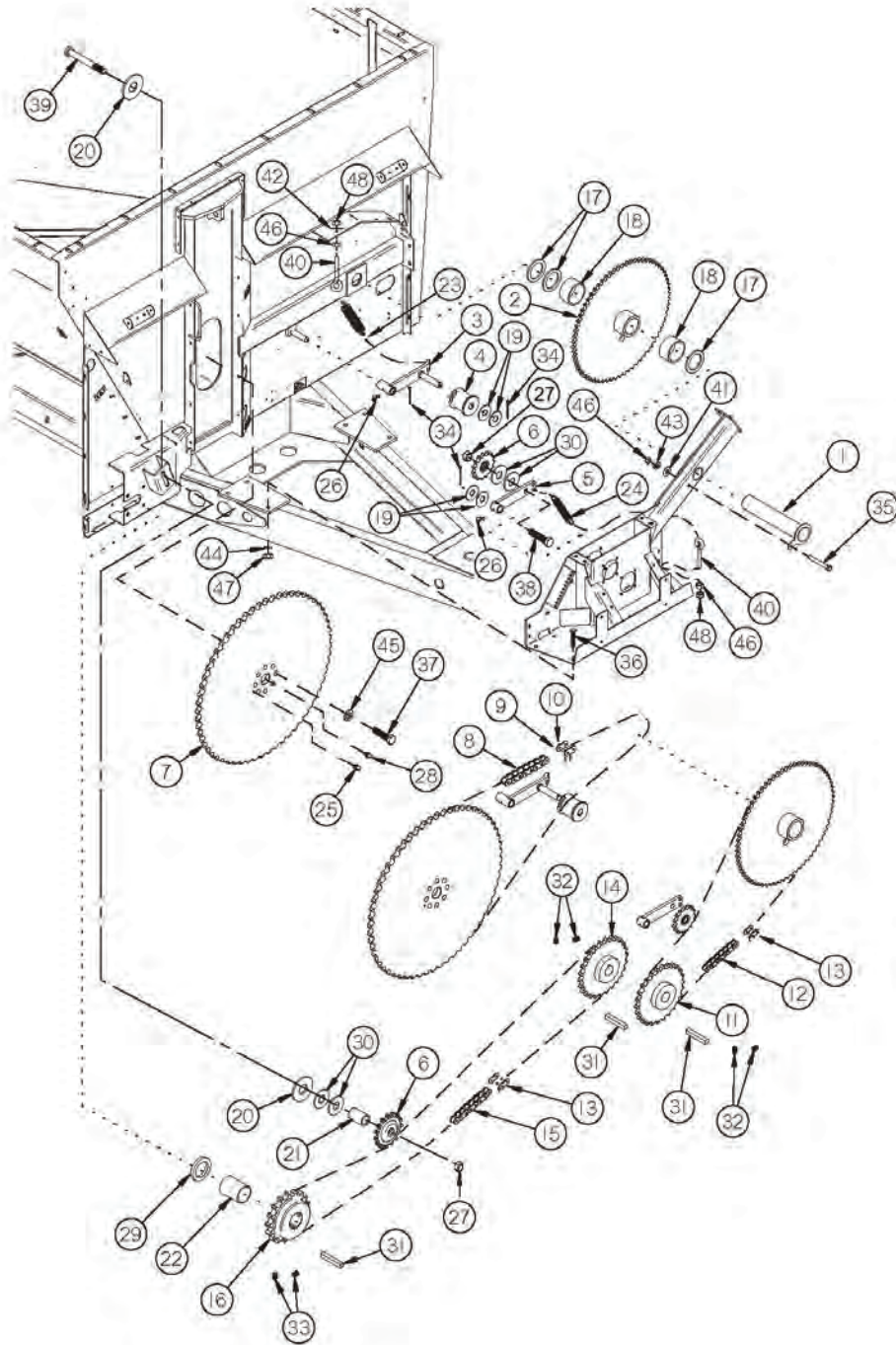

FIGURE 2

AUGER/EXPELLER DRIVE

<u>ITEM</u>	<u>QTY</u>	<u>PART#</u>	<u>DESCRIPTION</u>
34	3	YPCT05010	COTTER PIN, 5/32 X 1-1/2
35	1	YBHH12110	BOLT HEX, 3/8 X 2-3/4 G5
36	6	YBHH20010	BOLT HEX, 5/8 X 1-1/2 G5
37	8	YBHH24041	BOLT HEX, 3/4 X 2-3/4 G8
38	1	YBHH24050	BOLT HEX, 3/4 X 3 G5
39	1	YBHH24055	BOLT HEX, 3/4 X 3-1/2 G5
40	2	YBTE12025	BOLT TURNED EYE, 3/8 X 3
41	1	YWFL10005	WASHER, FLAT, 5/16
42	1	YWFL12005	WASHER, FLAT, 3/8
43	1	YWLO12005	WASHER, LOCK, 3/8
44	6	YWLO20005	WASHER, LOCK, 5/8
45	8	YWLO24005	WASHER, LOCK, 3/4
46	3	YNHX12005	NUT HEX, 3/8
47	6	YNHX20005	NUT HEX, 5/8
48	2	YNNY12005	NUT HEX, NYLON LOCKNUT, 3/8 G2

FIGURE 3 **EXPELLER/DISCHARGE GATE/BEARINGS**

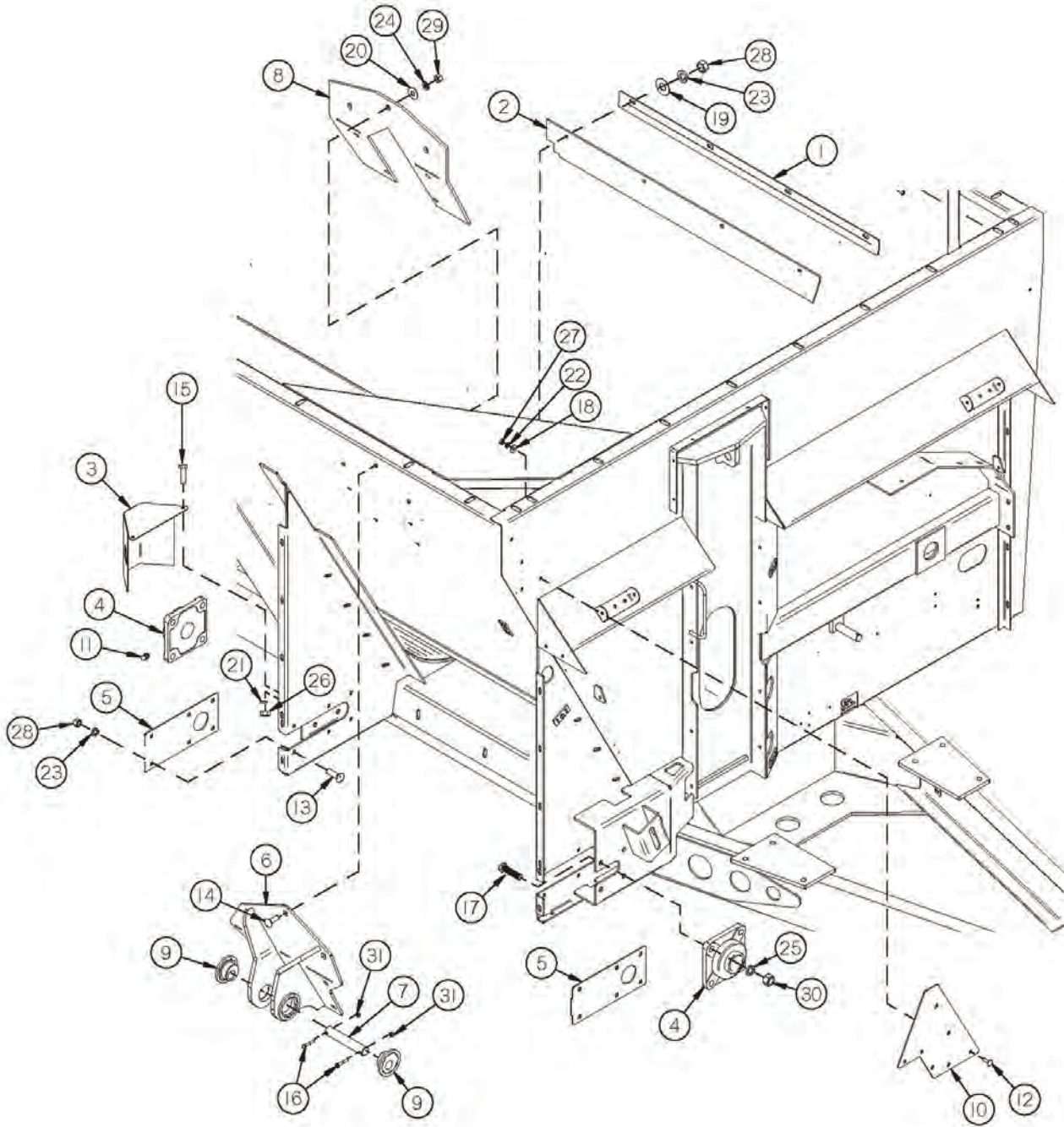

FIGURE 3

EXPELLER/DISCHARGE GATE/BEARINGS

<u>ITEM</u>	<u>QTY</u>	<u>PART#</u>	<u>DESCRIPTION</u>
1	1	TS43	DOOR SEAL CLAMP
2	1	TS44	EXPELLER DOOR SEAL TOP
3	1	TS45	EXPELLER BEARING SHIELD
4	2	HGV41	EXPELLER BEARING
5	2	TS47	COVER PLATE
6	1	APX3WE69	CYLINDER MOUNT
7	1	APX3SH15	DOOR CYLINDER PIN TOP
8	1	APX33G52	DOOR CYLINDER REINFORCEMENT
9	2	DWM314	HEX PLUG
10	1	APX310G66	BOLT ON INDICATOR MOUNT
11	1	G89	STRAIGHT GREASE ZERK, 1/4 X 90
12	4	YBCR10010	BOLT CARRIAGE, 5/16 X 1 G5
13	12	YBCR12010	BOLT CARRIAGE, 3/8 X 1 G5
14	7	YBCR16010	BOLT CARRIAGE, 1/2 X 1-1/2 G5
15	2	YBHH08100	BOLT HEX, 1/4 X 3/4 G5
16	2	YBHH08025	BOLT HEX, 1/4 X 1-1/2 G5
17	8	YBHH18010	BOLT HEX, 9/16 X 1-3/4 G5
18	4	YWFL06010	WASHER FLAT, 3/16
19	4	YWFL12005	WASHER FLAT, 3/8
20	7	YWFL16005	WASHER FLAT, 1/2
21	2	YWLO08005	WASHER LOCK, 1/4
22	4	YWLO10005	WASHER LOCK, 5/16
23	16	YWLO12005	WASHER LOCK, 3/8
24	7	YWLO16005	WASHER LOCK, 1/2
25	8	YWLO18005	WASHER LOCK, 9/16
26	2	YNHX08005	NUT HEX, 1/4
27	4	YNHX10005	NUT HEX, 5/16
28	16	YNHX12005	NUT HEX, 3/8
29	7	YNHX16005	NUT HEX, 1/2
30	8	YNHX18005	NUT HEX, 9/16
31	2	YNTL08005	NUT HEX, TOP LOCK, 1/4

FIGURE 4 **EXPELLER/DISCHARGE GATE/DOOR**

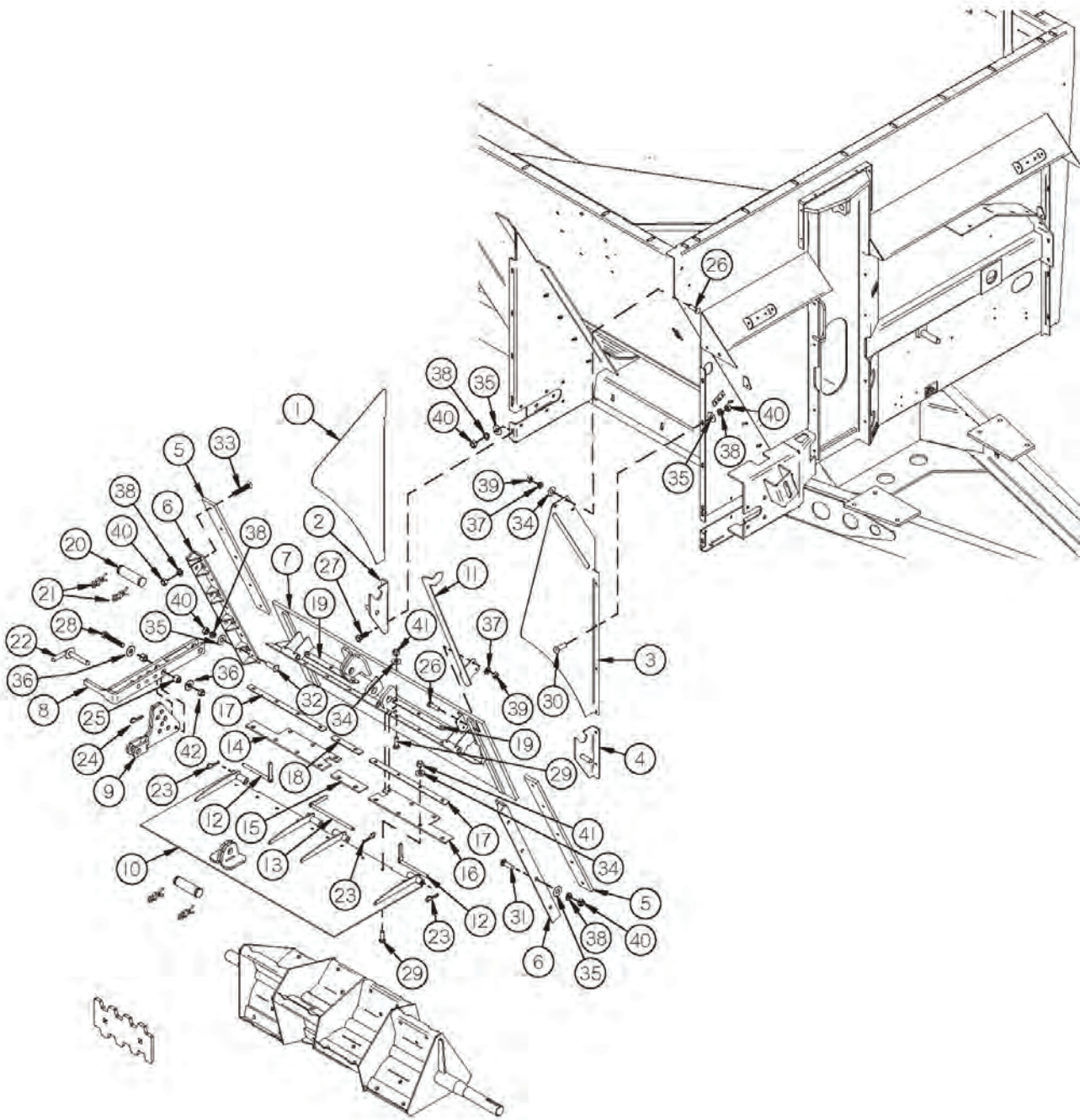

FIGURE 4

EXPPELLER/DISCHARGE GATE/DOOR

<u>ITEM</u>	<u>QTY</u>	<u>PART#</u>	<u>DESCRIPTION</u>
1	1	TS232	EXPPELLER SPOUT LH
2	1	TS49	PAN HINGE BRACKET LH
3	1	TS233	EXPPELLER SPOUT RH
4	1	TS51	PAN HINGE BRACKET RH
5	2	TS52	DOOR SLIDER POLY
6	2	TS53	EXPPELLER DOOR GUIDE
7	1	84592	EXPPELLER DOOR
8	1	TS55	DEFLECTOR ADJUSTMENT HANDLE
9	1	TS56	DEFLECTOR ADJUSTMENT LINK
10	1	84594	ADJUSTABLE FLAT DEFLECTOR
11	1	TS58	DOOR INDICATOR
12	2	TS59	DEFLECTOR SIDE PIN
13	1	TS60	DEFLECTOR MID PIN
14	1	TS61	DEFLECTOR SEAL LH
15	1	TS62	MID DEFLECTOR SEAL
16	1	TS63	DEFLECTOR SEAL RH
17	2	TS64	SEAL STRAP LONG
18	1	TS65	MID SEAL STRAP
19	2	TS66	SEAL STRAP SHORT
20	2	T143	CYLINDER PIN
21	4	T144	CLIP PIN
22	1	TS69	CASTER LOCKING PIN
23	3	X97	HAIR PIN
24	1	WM378	HAIR PIN W/LANYARD
25	2	TS307	HANDLE PIVOT
26	5	YBHH10105	BOLT HEX, 5/16 X 3/4 G5
27	4	YBHH12010	BOLT HEX, 3/8 X 1 G5
28	1	YBHH16105	BOLT HEX, 1/2 X 3 G5
29	16	YBCR10010	BOLT CARRIAGE, 5/16 X 1 G5
30	8	YBCR12010	BOLT CARRIAGE, 3/8 X 1 G5
31	7	YBCR12020	BOLT CARRIAGE, 3/8 X 1-1/4 G5
32	1	YBCR12015	BOLT CARRIAGE, 3/8 X 1-1/2 G5
33	10	YSFS12005	SCREW FLAT HEAD SOCKET CAP, 3/8 X 1-1/4
34	19	YWFL10005	WASHER FLAT, 5/16
35	20	YWFL12005	WASHER FLAT, 3/8
36	2	YWFL16005	WASHER FLAT, 1/2
37	5	YWLO10005	WASHER LOCK, 5/16
38	30	YWLO12005	WASHER LOCK, 3/8
39	5	YNHX10005	NUT HEX, 5/16
40	30	YNHX12005	NUT HEX, 3/8
41	16	YNTL10005	NUT HEX, TOP LOCK, 5/16
42	1	YNTL16005	NUT HEX, TOP LOCK, 1/2

***MEANS NOT SHOWN**

FIGURE 5
EXPELLER/DISCHARGE GATE/PAN

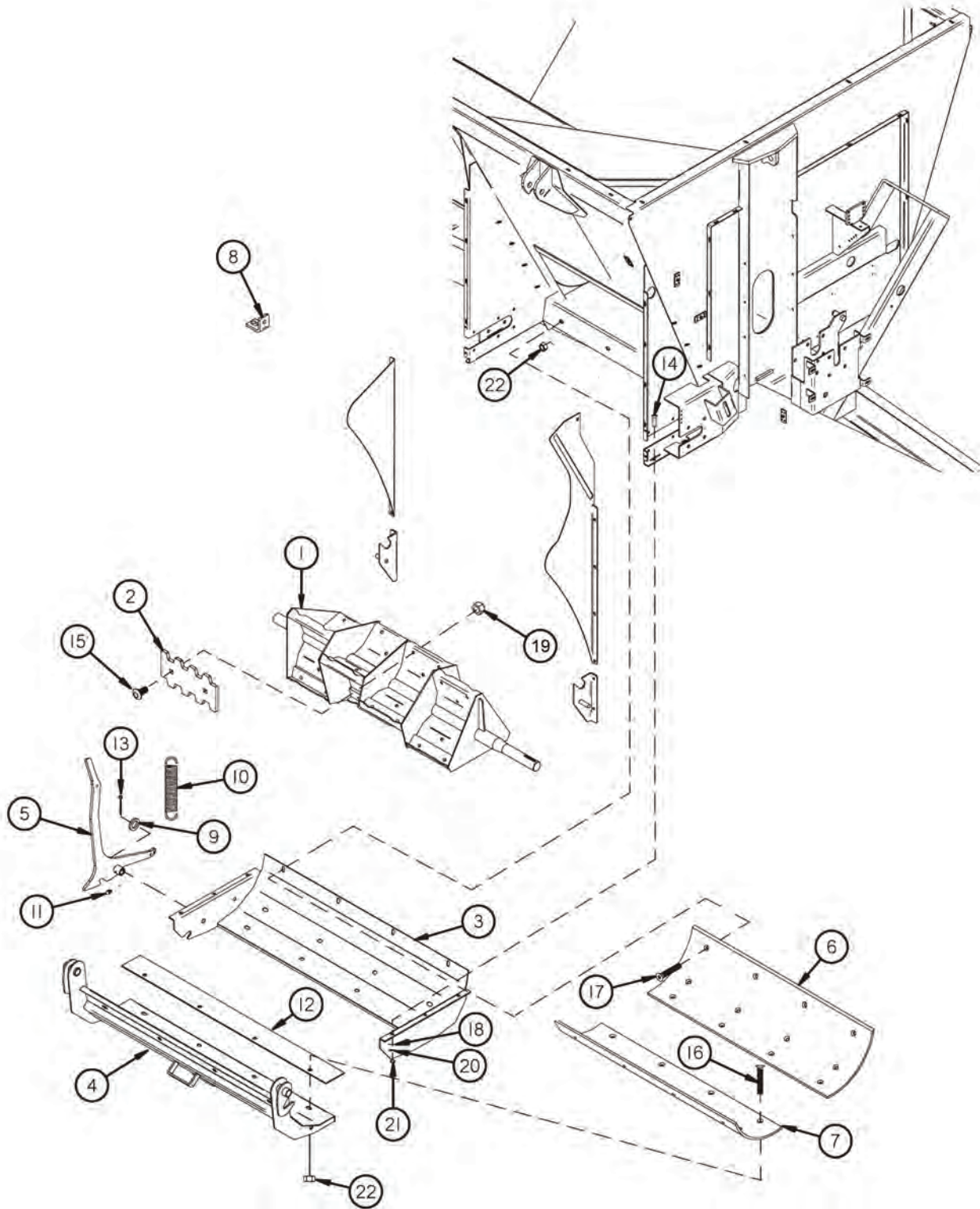

FIGURE 5

EXPELLER/DISCHARGE GATE/PAN

<u>ITEM</u>	<u>QTY</u>	<u>PART#</u>	<u>DESCRIPTION</u>
1	1	69616	EXPELLER
2	12	TS68	EXPELLER PADDLE
3	1	TS72	SWING AWAY PAN FRAME
4	1	TS73	SWING AWAY PAN
5	1	TS74	PAN LATCH HANDLE
6	1	TS75	EXPELLER BACK POLY
7	1	TS76	EXPELLER PAN POLY
8	1	56N146	SHIELD ANGLE
9	3	T73	SPACER
10	1	K103	SPRING
11	1	G89	GREASE ZERK
12	1	TS18	PAN RUBBER SEAL
13	1	YPCT06010	COTTER PIN, 3/16 X 1-1/4
14	6	YBCR10010	BOLT CARRIAGE, 5/16 X 1 G5
15	24	YBCR16019	BOLT CARRIAGE, 1/2 X 1-3/4 G8
16	20	YSFS16010	BOLT, FLAT SOK, 1/2 X 1-1/2
17	4	YSFS16020	BOLT, FLAT SOK, 1/2 X 1-3/4
18	6	YWFL10005	WASHER FLAT, 5/16
19	24	YNL16006	NUT HEX, TOP LOCK 1/2 G9
20	6	YWLO10005	WASHER LOCK, 5/16
21	6	YNHX10005	NUT HEX, 5/16
22	24	YNFG16003	NUT FLANGE, 1/2 GF

FIGURE 6 GUARDS/SHIELDS

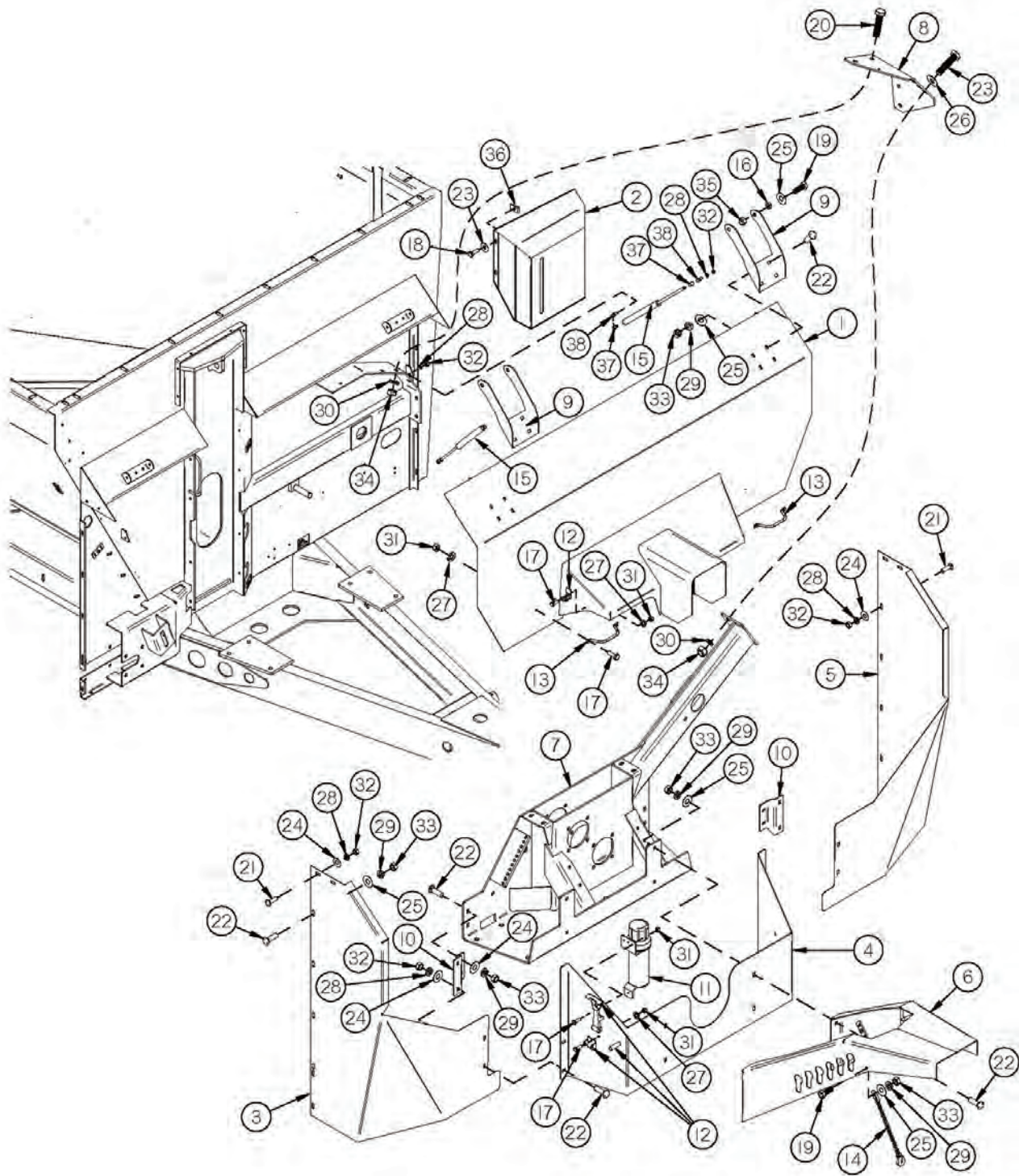

FIGURE 6

GUARDS/SHIELDS

<u>ITEM</u>	<u>QTY</u>	<u>PART#</u>	<u>DESCRIPTION</u>
1	1	TS234	SHIELD FRONT
2	1	TS235	CYLINDER COVER FRONT
3	1	TS236	SHIELD FRONT RH
4	1	TS237	GEARBOX SHIELD
5	1	TS238	SHIELD FRONT LH
6	1	TS239	HOSE HOLDER
7	1	TS240	GEARBOX
8	1	TS241	JACKSHAFT BRACE
9	2	TS242	SHIELD HINGE
10	2	TS243	SHIELD MOUNT FRONT
11	1	S522	MANUAL HOLDER
12	2	X233	LATCH
13	2	TS96	SHIELD HANDLE
14	1	TS130	CHAIN PTO HOLDER
15	2	TS244	GAS STRUT
16	4	GM180	SPACER
17	11	YBHH08015	BOLT HEX, 1/4 X 1/2 G5
18	4	YBHH08100	BOLT HEX, 1/4 X 3/4 G5
19	5	YBHH12010	BOLT HEX, 3/8 X 1 G5
20	8	YBHH20010	BOLT HEX, 5/8 X 1-1/2 G5
21	8	YBCR10030	BOLT CARRIAGE, 5/16 X 3/4 G5
22	24	YBCR12010	BOLT CARRIAGE, 3/8 X 1 G5
23	4	YWFL08005	WASHER FLAT, 1/4
24	8	YWFL10005	WASHER FLAT, 5/16
25	29	YWFL12005	WASHER FLAT, 3/8
26	3	YWFL20005	WASHER FLAT, 5/8
27	8	YWLO08005	WASHER LOCK, 1/4
28	14	YWLO10005	WASHER LOCK, 5/16
29	25	YWLO12005	WASHER LOCK, 3/8
30	8	YWLO20005	WASHER LOCK, 5/8
31	11	YNHX08005	NUT HEX, 1/4
32	14	YNHX10005	NUT HEX, 5/16
33	25	YNHX12005	NUT HEX, 3/8
34	8	YNHX20005	NUT HEX, 5/8
35	4	YNTL12005	NUT HEX, TOP LOCK, 3/8
36	4	YNUN08005	NUT U, EXTRUDED, 1/4
37	4	TS383	BALL 10MM
38	4	TS382	BALL MOUNT 10MM

FIGURE 7 **SPLASH GUARDS/RAILS**

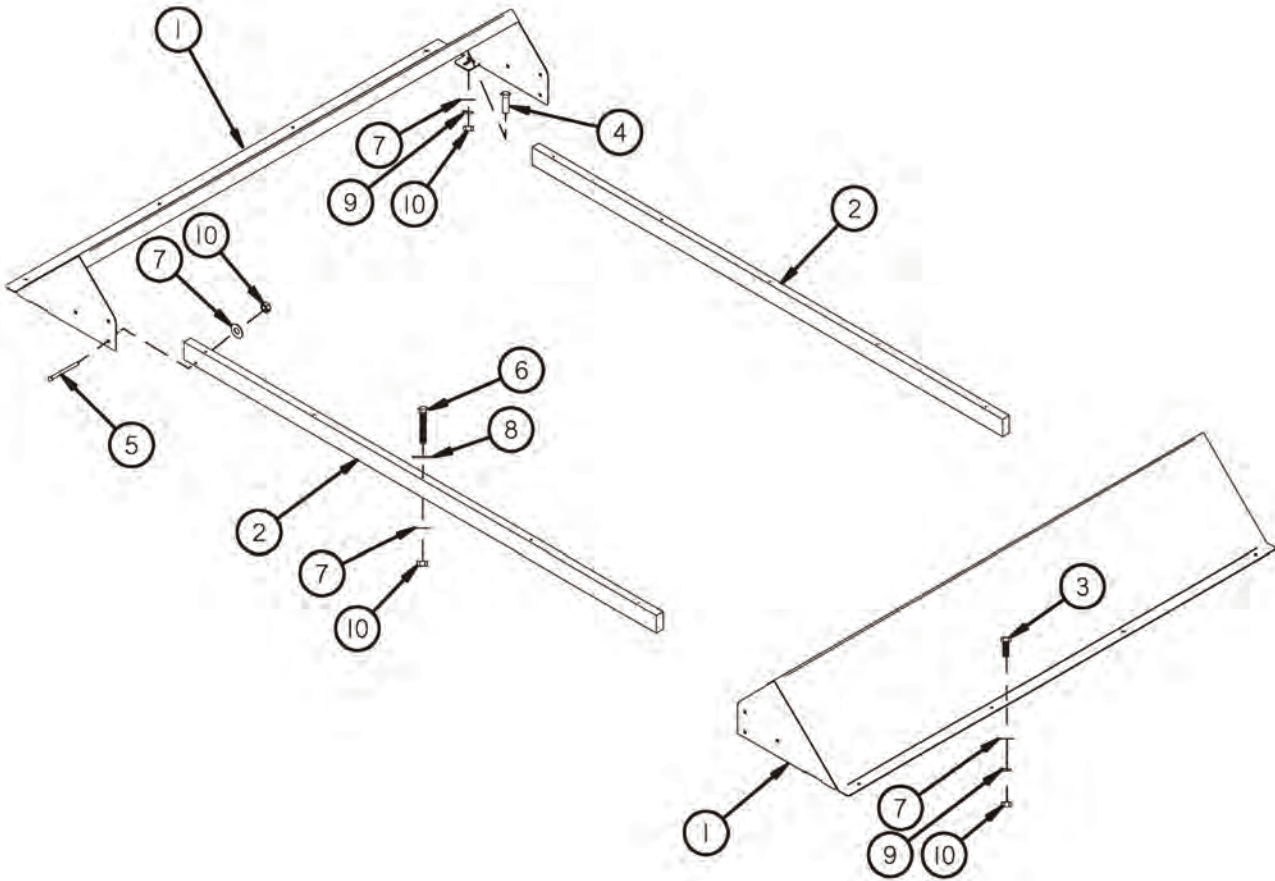

FIGURE 7
SPLASH GUARDS/RAILS

<u>ITEM</u>	<u>QTY</u>	<u>PART#</u>	<u>DESCRIPTION</u>
1	1	TS245	SPLASH GUARD
2	2	TS100	WOOD RAIL
3	8	YBHH12010	BOLT HEX, 3/8 X 1 G5
4	4	YBCR12010	BOLT CARRIAGE, 3/8 X 1 G5
5	12	YBCR12080	BOLT CARRIAGE, 3/8 X 3-1/4 G5
6	10	YBCR12123	BOLT CARRIAGE, 3/8 X 6-1/2 G5
7	34	YWFL12005	WASHER FLAT, 3/8
8	10	YWFL16005	WASHER FLAT, 1/2
9	12	YWLO12005	WASHER LOCK, 3/8
10	34	YNHX12005	NUT HEX, 3/8

FIGURE 8 HYDRAULICS

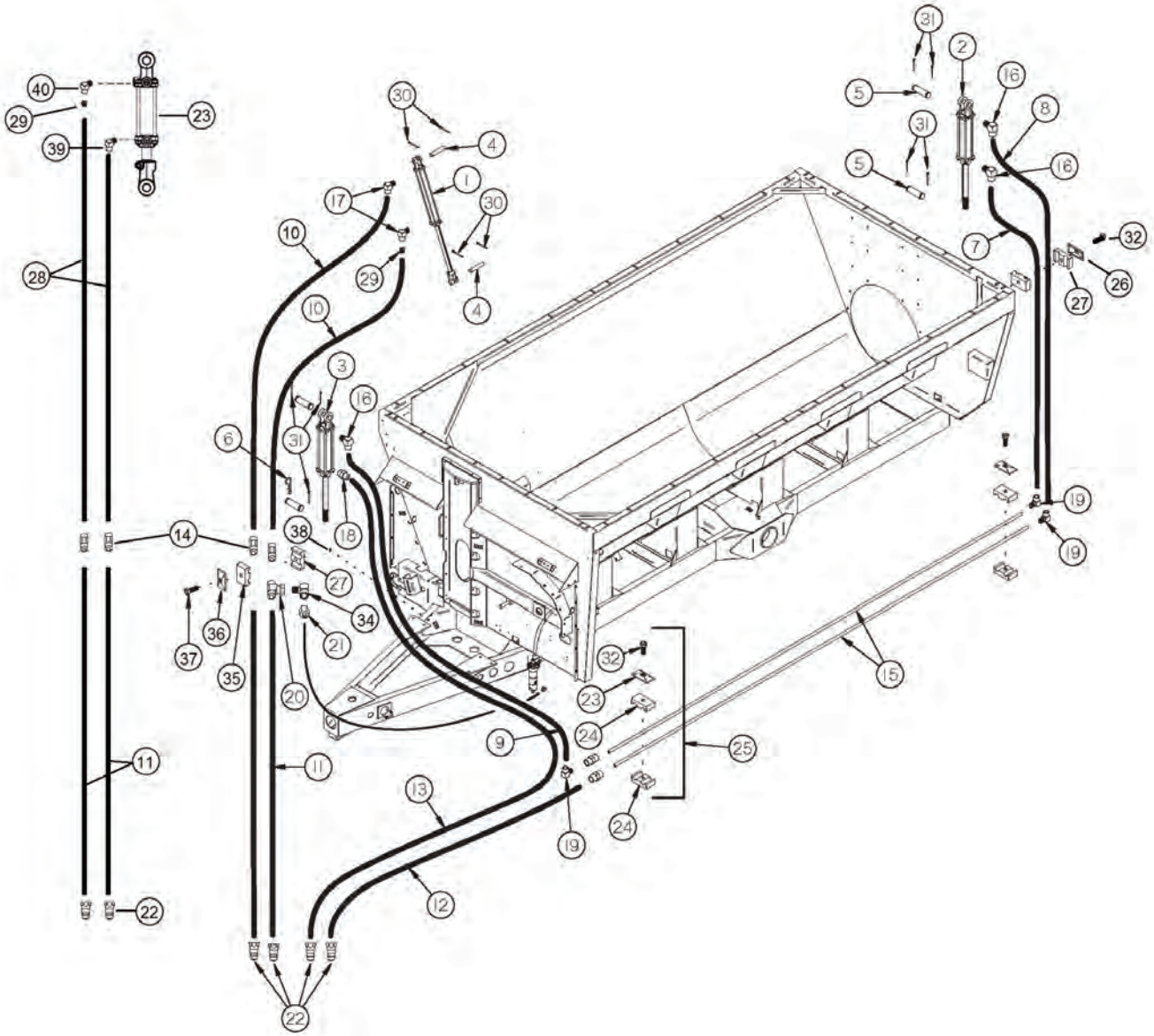

FIGURE 8 HYDRAULICS

<u>ITEM</u>	<u>QTY</u>	<u>PART#</u>	<u>DESCRIPTION</u>
1	1	23N111A	CYLINDER, 2 X 16
2	1	TS105	CYLINDER, 3-1/4 X 8
3	1	TS104	CYLINDER, 3 X 8
4	2	LW55	CYLINDER PIN
5	4	T143	CYLINDER PIN
6	1	YPHR02010	HAIR PIN, #21-07
7	1	TS115	HYDRAULIC HOSE, 1/2 X 49
8	1	TS247	HYDRAULIC HOSE, 1/2 X 60
9	1	TS248	HYDRAULIC HOSE, 1/2 X 66
10	2	85430	HYDRAULIC HOSE, 6 X 125
11	4	85664	HYDRAULIC HOSE, 6 X 94
12	1	TS251	HYDRAULIC HOSE, 1/2 X 132
13	1	TS252	HYDRAULIC HOSE, 1/2 X 184
14	4	CHM258	UNION (6 HTX-S)
15	2	TS116	HYDRAULIC LINE
16	3	TS135	8 MALE O-RING TO -8 MALE JIC 90°
17	4	CHM232	ELBOW (6-8 CTX-S)
18	1	TS137	8 MALE O-RING TO -8 MALE JIC
19	3	TFM83	8 FEMALE JIC SWIVEL TO -8 MALE JIC 90
20	1	CHM242	FITTING, TEE, 6JIC X 6JIC X 6JIC
21	1	73993	FITTING, ST,6JIC, 6NPTF, STL
22	6	DWM205	MALE QUICK COUPLER W/HYD TIP
23	3	70797	CYLINDER, HYDRAULIC, 10.2 X 14.2
24	6	TS118	LINE CLAMP BLOCK
25	3	TFM91	DOUBLE STEEL LINE CLAMP
26	6	56564	CLAMP TOP PLATE
27	6	56596	CLAMP CUSHION (SET OF 2)
28	2	85446	HYDRAULIC HOSE, 6 X127
29	2	57142	IN-LINE CONNECTOR, ORIFICE, 6-XHX7-S .031
30	4	YPCT05010	COTTER PIN, 5/32 X 1-1/2
31	7	YPCT06005	COTTER PIN, 3/16 X 1-1/2
32	7	56568	BOLT HEX 5/16 X 1-3/8 G5
33	6	56569	BOLT 5/16 X 1-3/4 G5
34	1	58127	FITTING 6 C6X-S
35	10	CHM278	CLAMP HALF 3/8" HOSE (SET OF 2)
36	11	56563	CLAMP TOP PLATE
37	4	YBFB10225	BOLT FLANGE, 5/16 X 2-1/4 G5
*	1	YBFB10300	BOLT FLANGE, 5/16 X 3 G5
38	1	YNFG10005	NUT FLANGE, 5/16-18, GF
39	2	CHM206	ELBOW (6-8 C50X-S)

***MEANS NOT SHOWN**

FIGURE 9 TANDEM AXLES

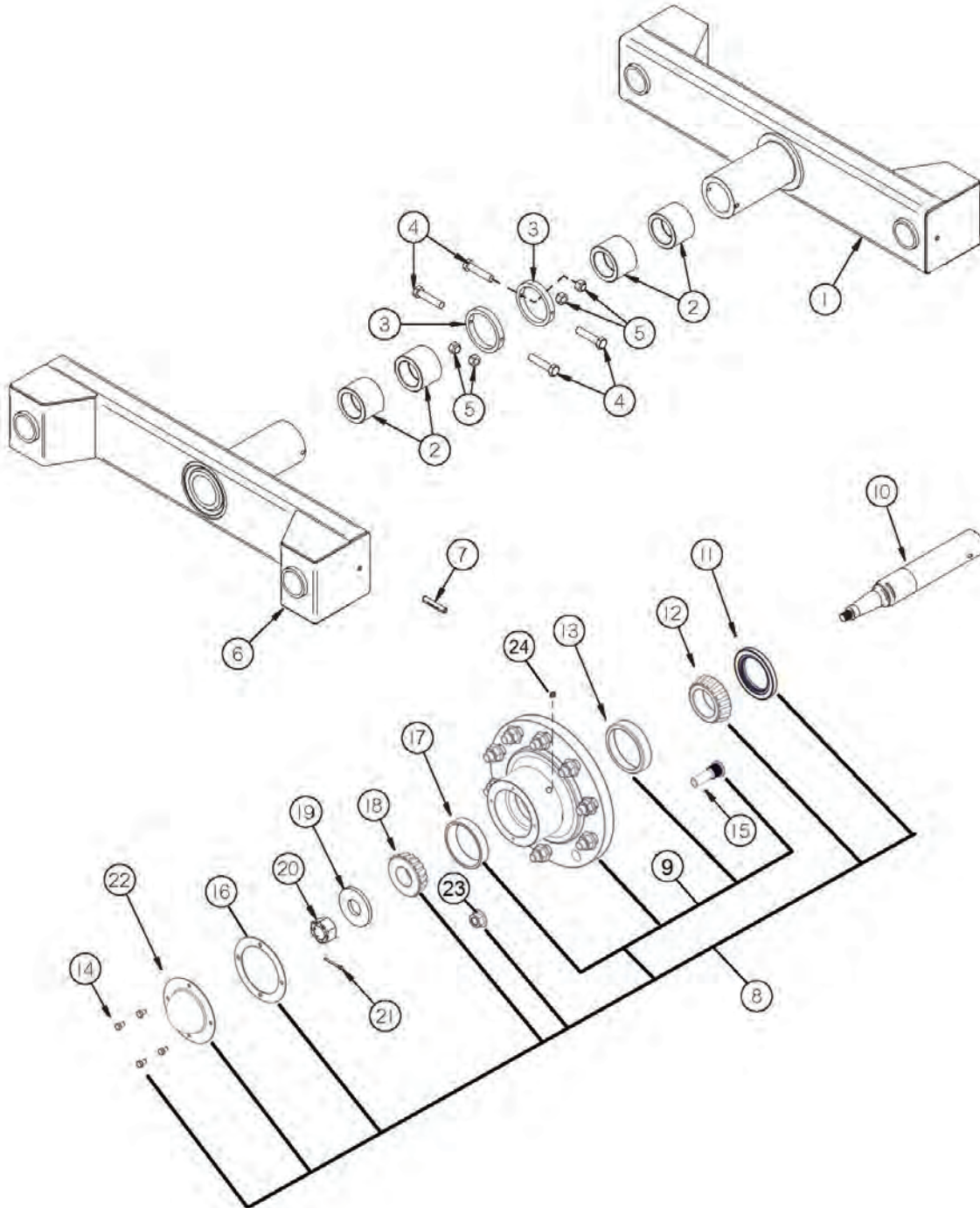

FIGURE 9 TANDEM AXLES

<u>ITEM</u>	<u>QTY</u>	<u>PART#</u>	<u>DESCRIPTION</u>
1	1	TS254	TANDEM AXLE 12000 LH
2	4	70145	NYLATRON BUSHING, 6-1/2 OD X 6 ID X 3
3	2	TS257	AXLE COLLAR
4	4	YBHH16095	BOLT HEX, 1/2 X 2-1/4 G5
5	4	YNTL16005	NUT HEX, 1/2
6	1	TS258	TANDEM AXLE 12000# RH
7	4	YPEX16020	EXPANSION PIN, 1/2 X 4
8	4	54508	HUB COMPLETE W/KOYO BEARINGS
9	4	54507	HUB W/KOYO RACES
10	4	TS46	TANDEM SPINDLE
11	4	60N5	GREASE SEAL
12	4	54505	INNER BEARING KOYO
13	4	54504	INNER RACE KOYO
14	16	YBHH10020	BOLT HEX, 5/16 X 1/2 G5 ZC
15	40	YBSD24010	BOLT STUD, 3/4 X 2-3/4 X 3/4 G8
16	4	56234	HUB CAP GASKET
17	4	54503	OUTER RACE KOYO
18	4	54506	OUTER BEARING KOYO
19	4	60N2	SPINDLE WASHER
20	4	YNCA36005	NUT CASTLE, 1-1/4
21	4	YPCT07005	COTTER PIN, 7/32 X 2
22	4	60N11	HUB CAP
23	40	YNWL24005	NUT WHEEL, FLANGE, 3/4 G8
24	4	BFR28	GREASE ZERK, 1/8

FIGURE 10 OPTIONAL TANDEM AXLES

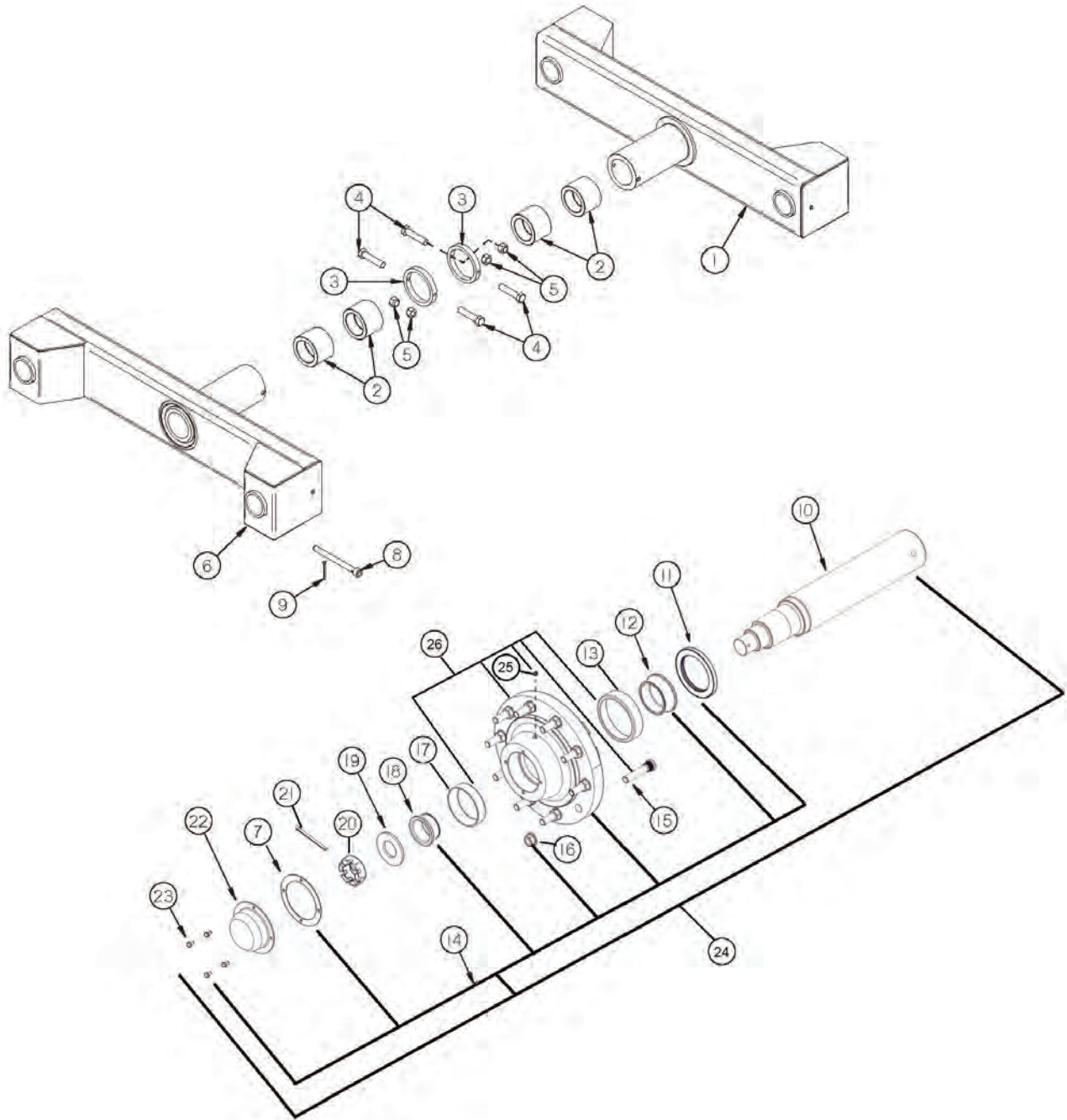

FIGURE 10

OPTIONAL TANDEM AXLES

<u>ITEM</u>	<u>QTY</u>	<u>PART#</u>	<u>DESCRIPTION</u>
1	1	TS255	TANDEM AXLE 15000# LH
2	4	70145	NYLATRON BUSHING, 6-1/2 X 6 X 3
3	2	TS257	AXLE COLLAR
4	4	YBHH16095	BOLT HEX, 1/2 X 2-1/4 G5
5	4	YNL16005	NUT HEX, 1/2
6	1	TS259	TANDEM AXLE 15000# RH
7	4	56531	HUB CAP GASKET
8	4	TS260	SPINDLE PIN
9	4	YPCT06020	COTTER PIN, 3/16 X 2
10	4	TS394	TANDEM SPINDLE
11	4	TS387	GREASE SEAL
12	4	TS388	INNER BEARING
13	4	TS389	INNER RACE
14	4	56535	HUB COMPLETE
15	40	YBSD24015	BOLT STUD, 3/4 X 3-7/8 X 9/16 G8
16	40	BFR618	NUT FLANGE, 3/4
17	4	TS390	OUTER RACE
18	4	TS391	OUTER BEARING
19	4	TS392	SPINDLE WASHER
20	4	YNSL44005	NUT SLOT, 2 - 12 G2
21	4	YPCT10020	COTTER PIN, 5/16 X 4
22	4	TS393	HUB CAP
23	16	YBHH10020	BOLT HEX, 5/16 X 1/2 G5
24	4	56537	HUB/SPINDLE ASSY, 10 BOLT
25	4	BFR28	GREASE ZERK, 1/8
26	4	56538	HUB W/RACES

FIGURE 11 OILER KIT

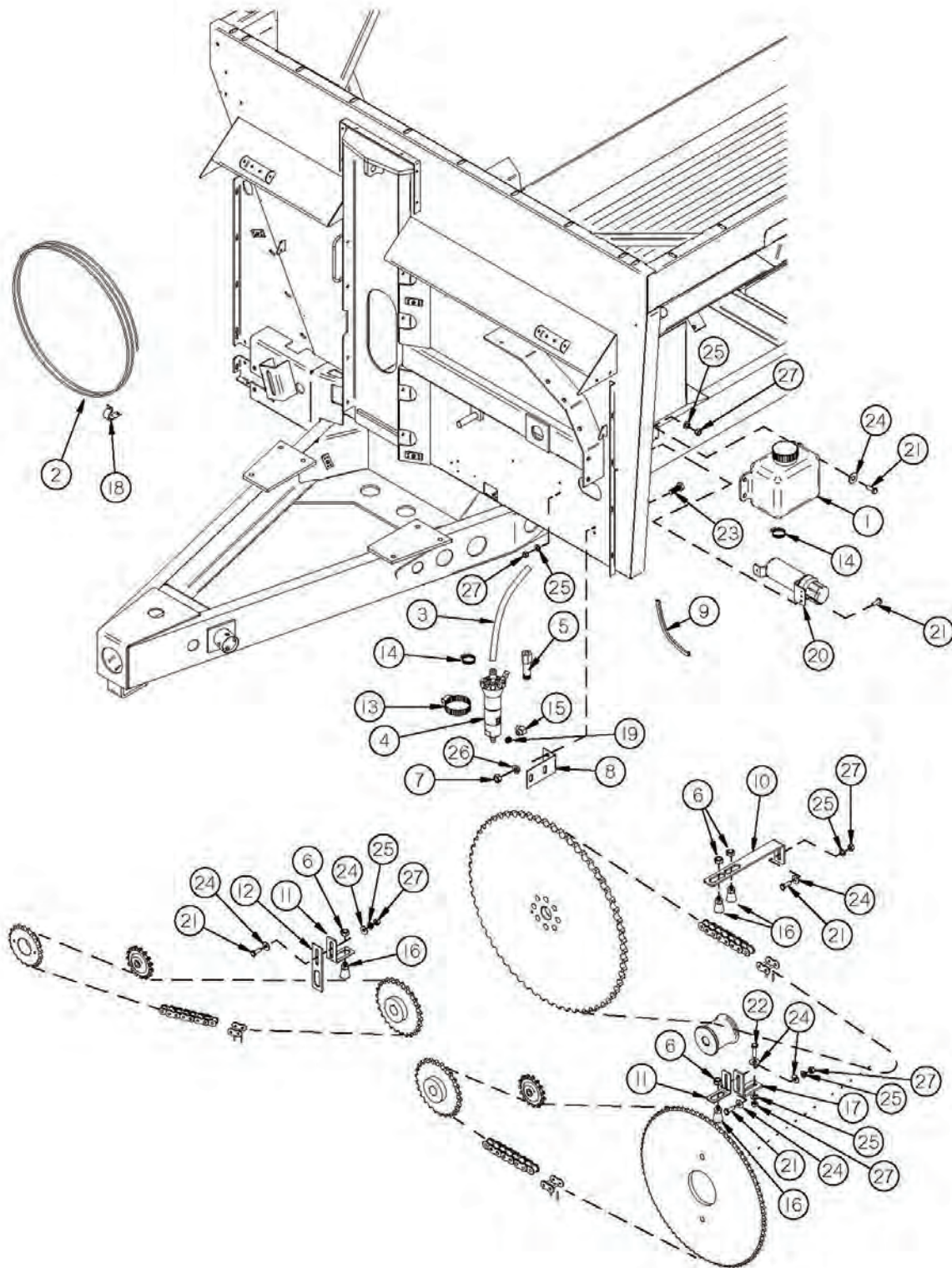

FIGURE 11 OILER KIT

<u>ITEM</u>	<u>QTY</u>	<u>PART#</u>	<u>DESCRIPTION</u>
1	1	HGV63	RESERVOIR
2	1	HGV71	OIL TUBE
3	1	HGV66	FILLER HOSE
4	1	HGV82	PUMP COMPLETE
5	4	HGV84	MANIFOLD
6	4	YNHX16005	HEX NUT, 1/2
7	4	YNHX12005	HEX NUT, 3/8
8	1	HGV68	PUMP MOUNT BRACKET
9	1	HGV77	EDGING
10	1	TS322	BRUSH BRACKET, EXTRA LONG
11	2	TS98	OILER BRUSH BRACKET, SINGLE
12	1	HGV70	BRACKET MOUNT
13	1	HGV74	HOSE CLAMP, 2
14	2	HGV75	HOSE CLAMP, 1
15	1	HGV65	O-RING/JIC ELBOW
16	4	HGV67	BRUSH
17	1	TS321	OILER HANGER 1
18	2	HGV162	RUBBER WIRE HOLDER, 1/2
*	2	TS269	RUBBER WIRE HOLDER, 1/4
*	2	YSHW08005	WASHER HEX, SCREW ROLLING, 1/4 X 3/8
19	1	TS198	ORIFICE, .015
20	1	S522	MANUAL HOLDER
21	10	YBHH08100	BOLT HEX, 1/4 X 3/4 G5
22	1	YBHH08010	BOLT HEX, 1/4 X 1 G5
23	2	YBHH12135	BOLT HEX, 3/8 X 3/4 G5
24	10	YWFL08005	WASHER FLAT, 1/4
25	11	YWLO08005	WASHER LOCK, 1/4
26	2	YWLO12005	WASHER LOCK, 3/8
27	11	YNHX08005	NUT HEX, 1/4

***MEANS NOT SHOWN**

FIGURE 12 FRONT GREASE LINES

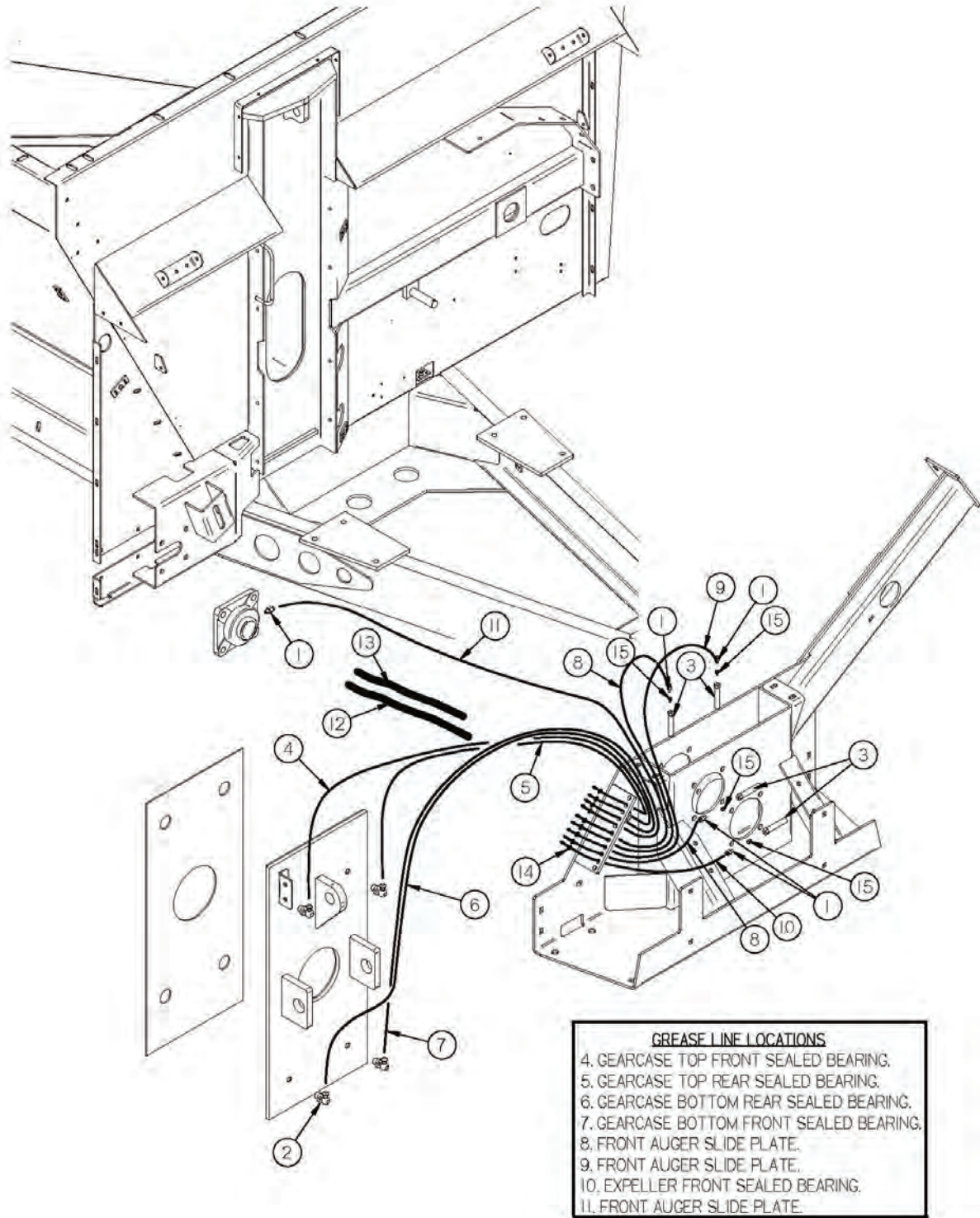

FIGURE 12

FRONT GREASE LINES

<u>ITEM</u>	<u>QTY</u>	<u>PART#</u>	<u>DESCRIPTION</u>
1	5	66078	COUPLING, 1/8 FEMALE PIPE & 1/8 FEMALE PIPE
2	4	GM30	ELBOW, (4C50X-S)
3	4	66077	NIPPLE
4	1	TS265	GREASE LINE, 81
5	1	TS266	GREASE LINE, 82
6	1	TS267	GREASE LINE, 97
7	1	TS268	GREASE LINE, 101
8	2	TS270	GREASE LINE, 10.5
9	1	TS271	GREASE LINE, 16
10	1	TS272	GREASE LINE, 17.5
11	1	TS273	GREASE LINE, 47.75
12	1	TS246	SPLIT LOOM, 3/4 X 18
13	1	TS332	SPLIT LOOM, 3/4 X 14
*	2	HGV72	RUBBER WIRE HOLDER, 3/4
14	10	YNJM76005	NUT JAM, #10 A2
15	4	66079	HEX ADAPTER, 1/4 FEMALE & 1/8 FEMALE PIPE

***MEANS NOT SHOWN**

FIGURE 13 LIGHTING

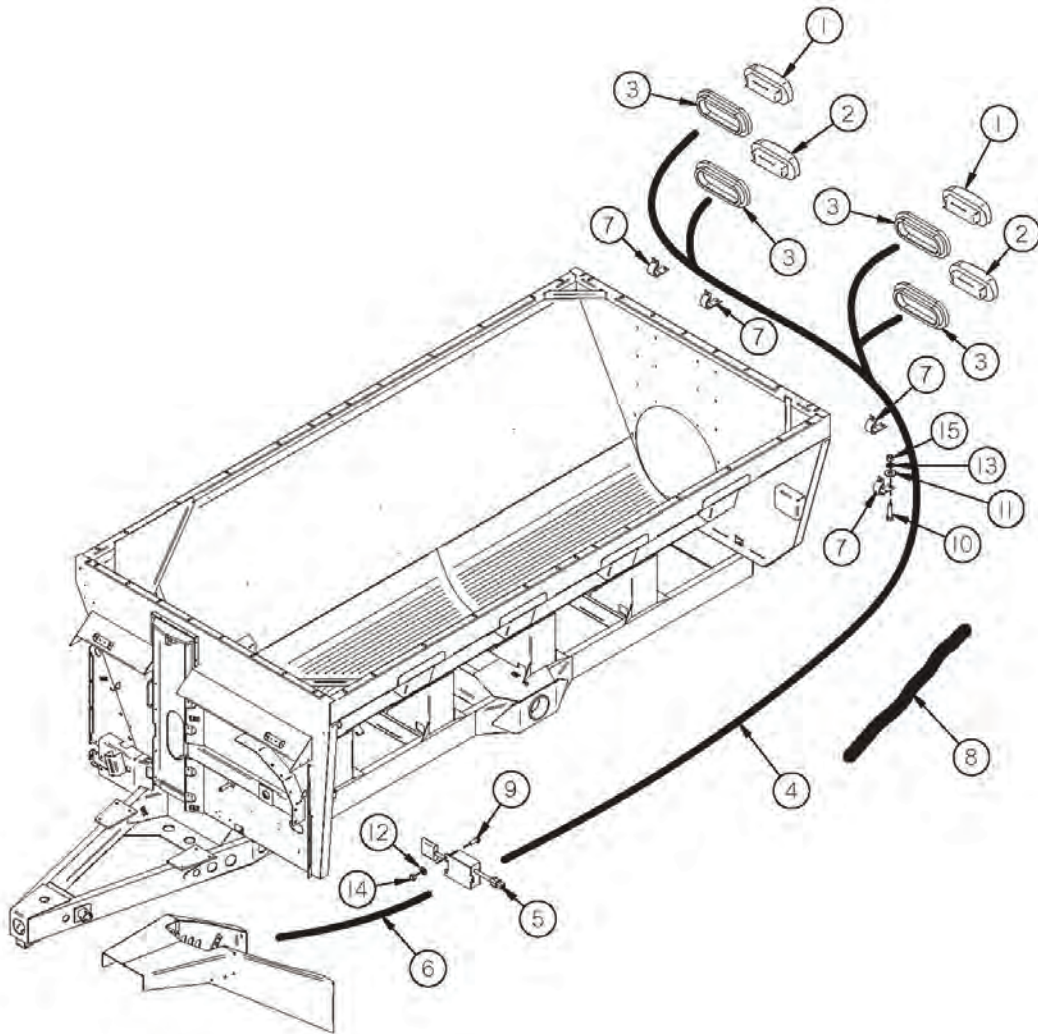

FIGURE 13 LIGHTING

<u>ITEM</u>	<u>QTY</u>	<u>PART#</u>	<u>DESCRIPTION</u>
1	2	S309	OVAL AMBER HAZARD TAIL LIGHT
2	2	S310	OVAL RED STOP/TURN TAIL LIGHT
3	4	S308	OVAL LIGHT GROMMET
4	1	56N155	HARNESS - TAILLIGHT
5	1	69908	MODULE CONTROL BLINKER
6	1	TS317	HARNESS MODULE TO TRACTOR
7	4	HGV162	CUSHION WIRE CLAMP, 1/2
8	1	TS129	SPIRAL WRAP, 30
9	3	YSPP64010	SCREW MACHINE PAN, #10
10	4	YBHH10105	BOLT HEX, 5/16 X 3/4 G5
11	4	YWFL10005	WASHER FLAT, 5/16
12	3	YWLO08005	WASHER LOCK, 1/4
13	4	YWLO10005	WASHER LOCK, 5/16
14	3	YNHX64005	NUT HEX, MACHINE, #10 - 32
15	4	YNHX10005	NUT HEX, MACHINE, #10 - 32

FIGURE 14
AUGER

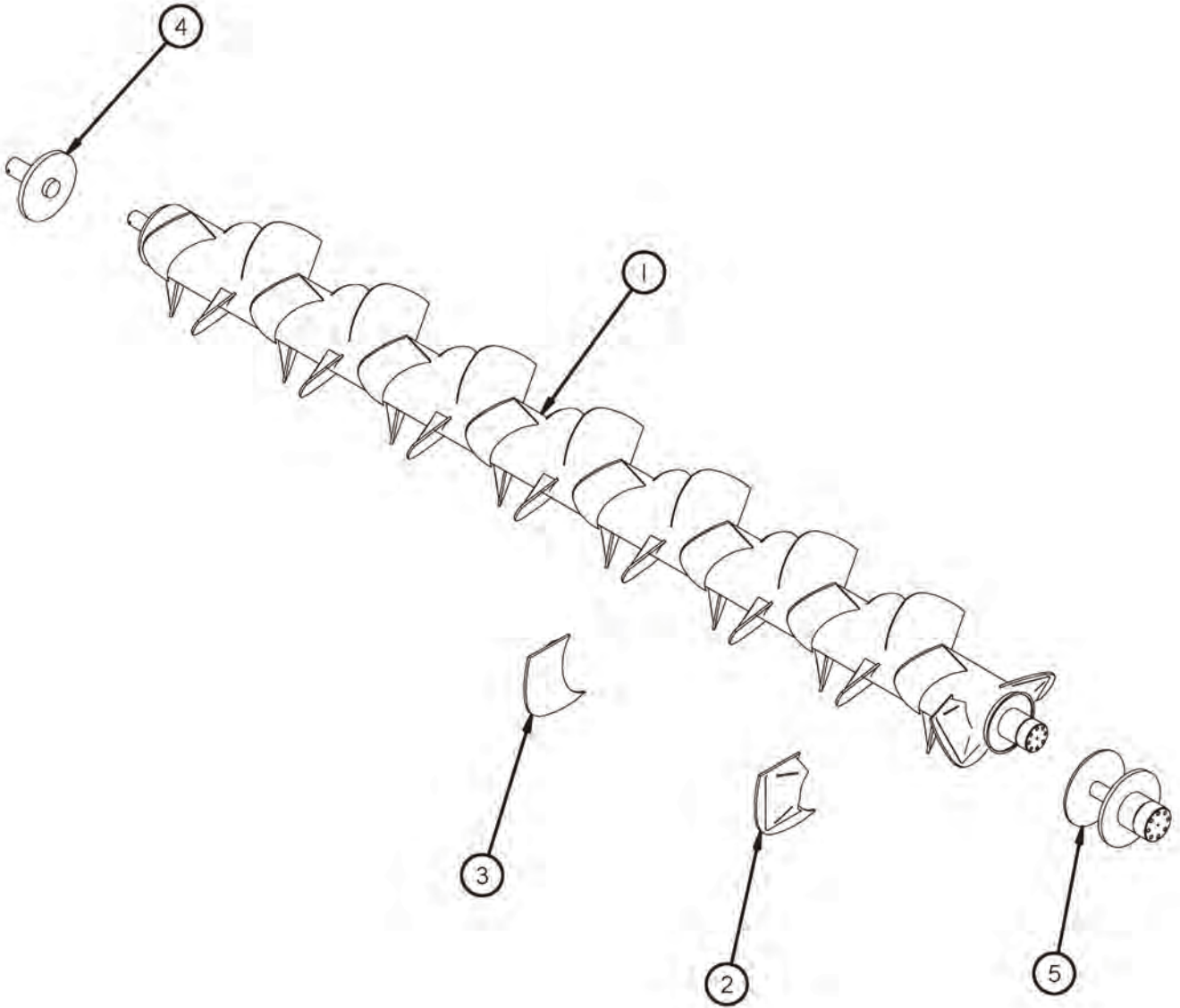

FIGURE 14 **AUGER**

<u>ITEM</u>	<u>QTY</u>	<u>PART#</u>	<u>DESCRIPTION</u>
1	1	TS200	AUGER
2	2	TS275	FRONT AUGER PADDLE
3	37	TS276	BACK AUGER PADDLE
4	1	TS277	BACK AUGER
5	1	TS278	AUGER INPUT SHAFT

FIGURE 15 **GEARBOX**

<u>ITEM</u>	<u>QTY</u>	<u>PART#</u>	<u>DESCRIPTION</u>
1	1	TS240	GEARBOX
2	1	TS279	GEARBOX COVER
3	1	TS280	SECONDARY SHAFT
4	1	TS281	SPUR GEAR, (40T)
5	1	TS282	SPLINED INPUT SHAFT
6	1	TS283	SPUR GEAR, (20T)
7	4	TS284	BUSHING
8	4	TS285	BEARING
9	A/R	TS286	SHIM, 1/32 THICK
10	A/R	S36	SHIM, 3/16 THICK
*	A/R	S409	SHIM, 1/8 THICK
11	1	SD134	VENT PLUG
12	2	56N174	SQUARE KEY, 3/8 X 2
13	4	YBHH10075	BOLT HEX, 5/16 X 2 G8
14	4	YBHH12010	BOLT HEX, 3/8 X 1 G5
15	15	YBHH16065	BOLT HEX, 1/2 X 2 G5
16	1	YBHH16080	BOLT HEX, 1/2 X 2-1/2 G5
17	4	YWFL12005	WASHER FLAT, 3/8
18	4	YWLO12005	WASHER LOCK, 3/8
19	16	YWLO16005	WASHER LOCK, 1/2
20	4	YNHX12005	NUT HEX, 3/8
21	16	YNHX16005	NUT HEX, 1/2
22	1	YNJM16005	NUT HEX JAM, 1/2
23	4	YNTL10005	NUT HEX, TOP LOCK, 5/16
24	2	DWM159	PIPE PLUG, 3/4
*	1	APX3AS07	GEARBOX

***MEANS NOT SHOWN**

A/R MEANS AS REQUIRED

FIGURE 16
AUGER FRONT & REAR HYDRAULIC CYLINDER

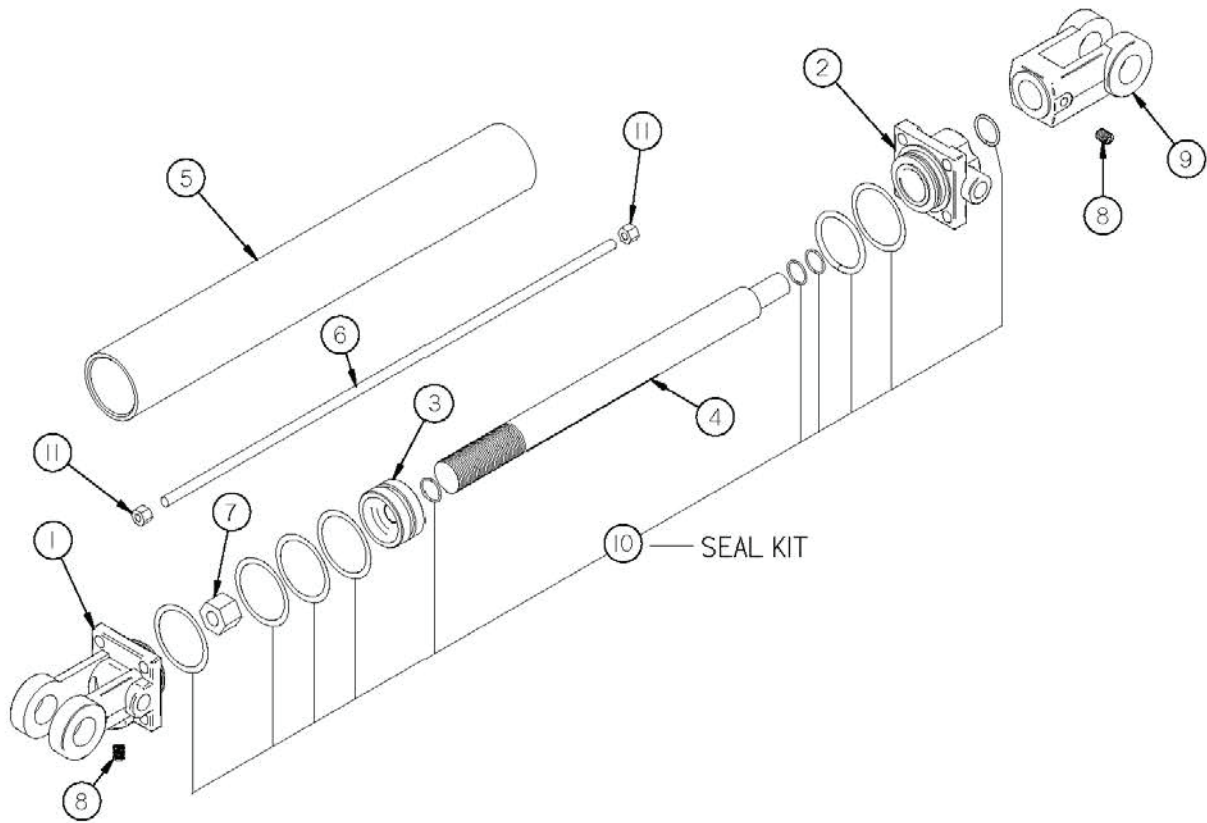

FIGURE 16
AUGER FRONT & REAR HYDRAULIC CYLINDER

<u>ITEM</u>	<u>QTY</u>	<u>PART# 3" BORE</u>	<u>PART# 3-1/4" BORE</u>	<u>DESCRIPTION</u>
1	1	TS160	TS176	BASE (3/4 - 16 SAE PORT)
2	1	TS158	TS174	HEAD (3/4 - 16 SAE PORT)
3	1	TS159	TS175	PISTON NUT
4	1	TS156	TS172	ROD
5	1	TS157	TS173	TUBE
6	4	TS153	TS171	TIE ROD
7	1	TS145	TS166	PISTON NUT
8	1	TS152	"	PLUG (3/4 - 16 SAE)
9	1	TS155	"	CLEVIS ASSEMBLY
10	1	TS163	TS177	SEAL KIT
11	8	TS144	TS165	TIE ROD NUT

FIGURE 17 **EXPELLER DOOR HYDRAULIC CYLINDER**

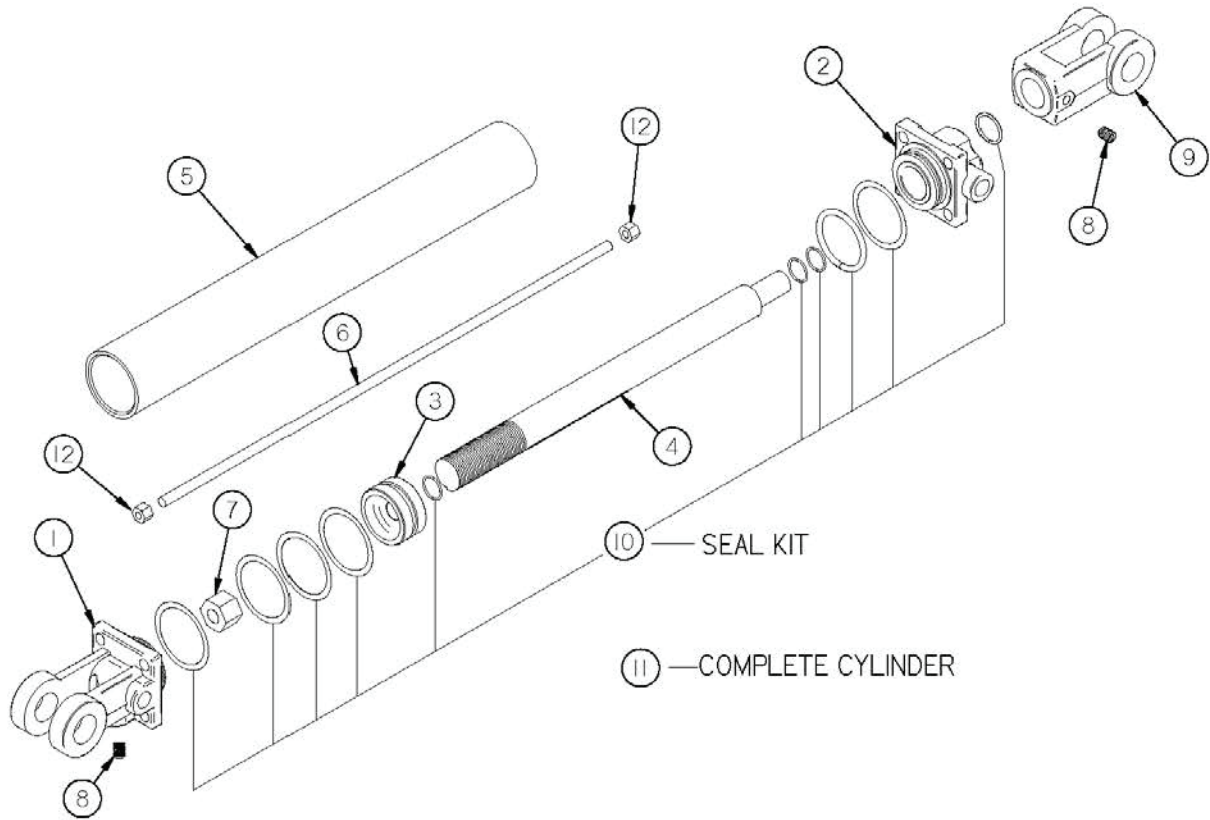

FIGURE 17
EXPELLER DOOR HYDRAULIC CYLINDER

<u>ITEM</u>	<u>QTY</u>	<u>PART#</u>	<u>DESCRIPTION</u>
1	1	23N142A	CLEVIS CAP
2	1	23N143	ROD CAP
*	1	56174	ROD CAP
3	1	23N144	PISTON
*	1	56180	PISTON
4	1	23N145A	ROD
5	1	23N146	CYLINDER TUBE
6	4	23N147	TIE ROD
7	1	23N148	PISTON NUT
8	2	23N149	PLUG
9	1	23N150A	ROD CLEVIS
10	1	23N151	SEAL KIT
*	1	56187	SEAL KIT
11	1	23N111A	HYDRAULIC CYLINDER, 2 X 16
*	1	56015	HYDRAULIC CYLINDER, 2 X 16
12	8	YNHX12005	NUT HEX, 3/8

***MEANS NOT SHOWN**

FIGURE 18
PTO (1000RPM 1-3/8)

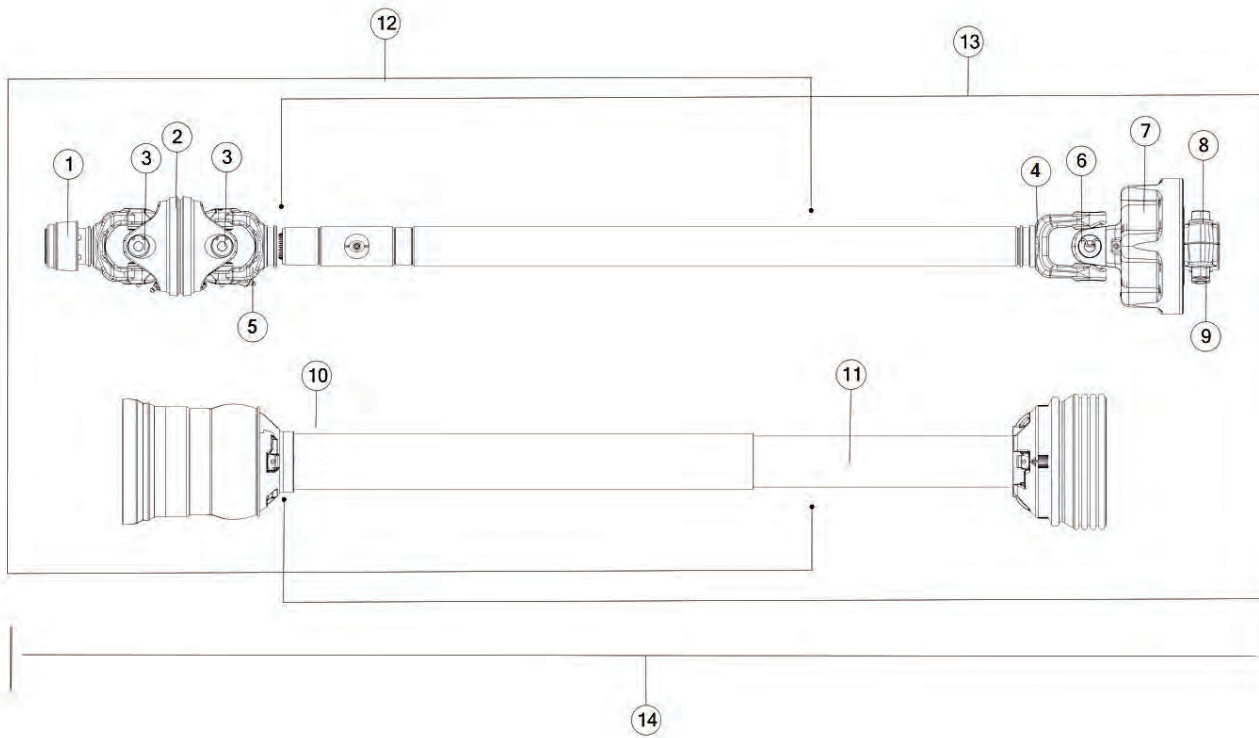

FIGURE 18
PTO (1000RPM 1-3/8)

<u>ITEM</u>	<u>QTY</u>	<u>PART#</u>	<u>DESCRIPTION</u>
1	1	63389	YOKE, AUTO-LOC
2	1	TS180	CENTER HOUSING
3	1	TS179	CROSS KIT
4	1	70569	PTO, YOKE, TUBE & SLIP SLEEVE, 1000 RPM
5	1	63390	YOKE & SHAFT
6	1	16SV179	CROSS KIT, 35R
7	1	70562	PTO, CLUTCH 35 AUTO, 15900 IN-LBF MIN.
8	1	YBFB20040	BOLT FLANGE, 5/8 X 3 G8
9	1	YNSF20005	NUT FLANGE, 5/8
10	1	TS288	OUTER GUARD
11	1	70570	SHIELD, PTO SHAFT INNER GUARD
12	1	TS292	JOINT & SHAFT HALF ASSM W/ GUARD
13	1	70576	PTO, JOINT & SHAFT HALF, GUARDED, 1000 RPM
14	1	70324	PTO, 1000 RPM, 19500 IN-LBF, AUTO
*	1	16SV274	SAFETY SLIDE LOCK REPAIR KIT
*	1	16SV383	GUARD REPAIR KIT
*	1	S402	ADMA SAFETY MANUAL

***MEANS NOT SHOWN**

FIGURE 19
PTO (1000RPM 1-3/4)

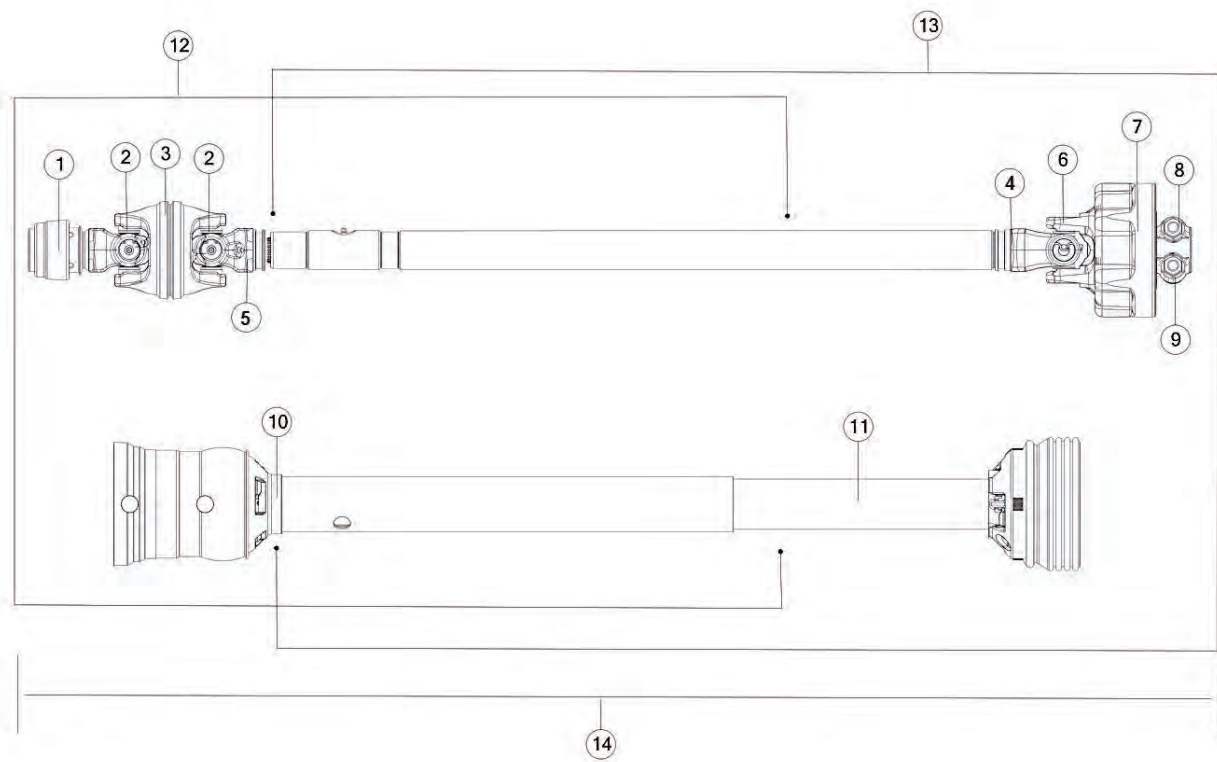

FIGURE 19
PTO (1000RPM 1-3/4)

<u>ITEM</u>	<u>QTY</u>	<u>PART#</u>	<u>DESCRIPTION</u>
1	1	TS193	AUTO LOCK YOKE ASSEMBLY
2	1	TS179	CROSS KIT
3	1	TS180	CENTER HOUSING
4	1	70569	PTO, YOKE, TUBE & SLIP SLEEVE, 1000 RPM
5	1	63390	YOKE & SHAFT
6	1	16SV179	CROSS & BEARING KIT
7	1	70562	PTO, CLUTCH 35 AUTO, 15900 IN-LBF MIN.
8	1	YNSF20005	NUT FLANGE, 5/8
9	1	YBFB20040	BOLT FLANGE, 5/8 X 3 G8
10	1	TS288	OUTER GUARD
11	1	70570	SHIELD, PTO SHAFT INNER GUARD
12	1	TS296	JOINT & SHAFT HALF ASSM. W/GUARD
13	1	70576	PTO, JOINT & SHAFT HALF, GUARDED, 1000 RPM
14	1	70328	PTO, 1000 RPM, 19500 IN-LBF, AUTO
*	1	16SV383	REPAIR KIT
*	1	16SV275	SIDE LOCK REPAIR KIT
*	1	S402	ADMA SAFETY MANUAL

***MEANS NOT SHOWN**

FIGURE 20
SCALE

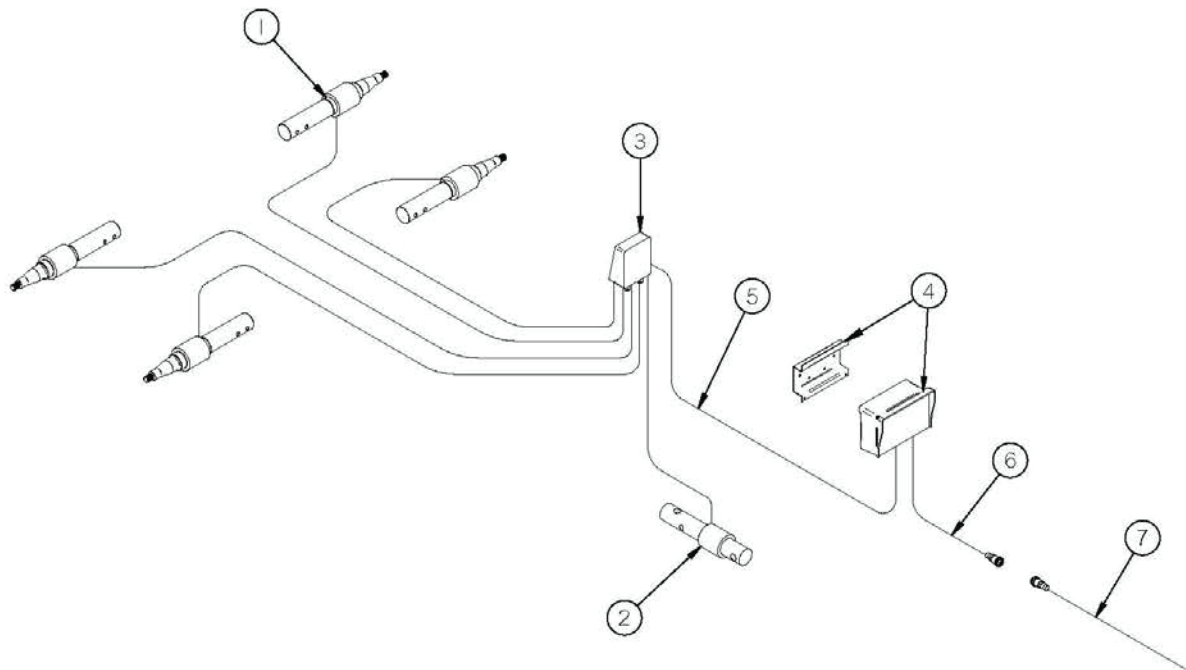

FIGURE 20 SCALE

<u>ITEM</u>	<u>QTY</u>	<u>PART#</u>	<u>DESCRIPTION</u>
1	4	TS334	LOAD CELL SPINDLE
*	4	TS335	LOAD CELL SPINDLE
2	1	TS336	HITCH LOAD CELL
3	1	TS83	JUNCTION BOX
4	1	GM408	SCALE HANGER BRACKET
*	1	TS337	SCALE DISPLAY W/GPS (OPTIONAL)
5	1	TS338	JUNCTION BOX CORD
6	1	TS385	POWER CORD
7	1	16SV269	TRACTOR POWER CORD

***MEANS NOT SHOWN**

FIGURE 21 COVER COMPONENTS

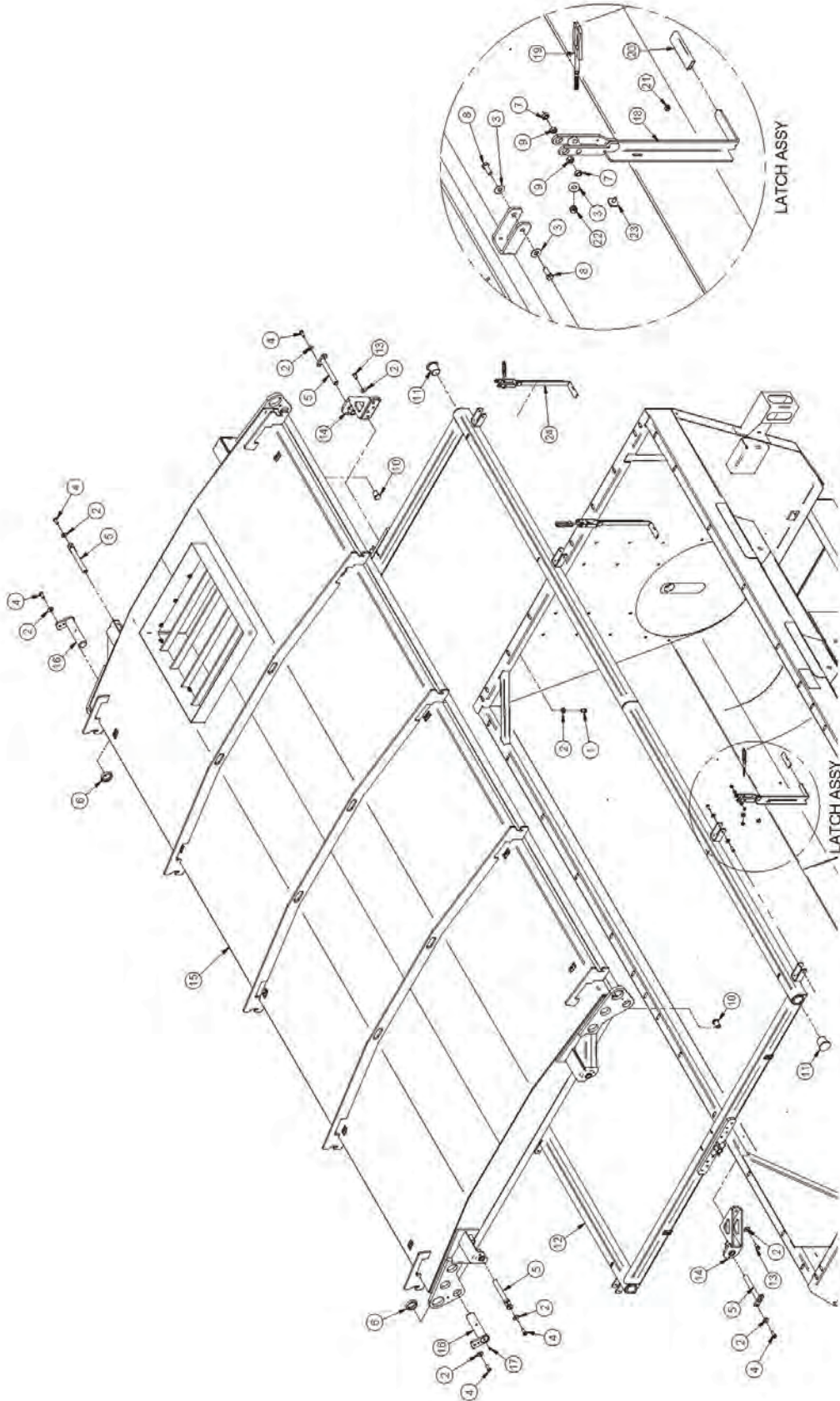

FIGURE 21

COVER COMPONENTS

<u>ITEM</u>	<u>QTY</u>	<u>PART#</u>	<u>DESCRIPTION</u>
1	46	YBHH16010	BOLT HEX, 1/2 X 1
2	56	YWFL16005	WASHER FLAT, 1/2
3	12	YWFL12005	WASHER FLAT, 3/8 G5
4	2	YBHH16045	BOLT HEX, 1/2 X 1-1/4 G5
5	4	0229WE05	HANDLE, CYLINDER PIN
6	2	0229TU05	HINGE SPACER
7	8	GM180	DOOR PIVOT
8	8	YBHH12010	BOLT HEX, 3/8 x 1 G5
9	8	YNRL12005	NUT HEX, REVERSIBLE-SIDE LOCK, 3/8
10	2	0229MS06	PIPE PLASTIC END PLUG
11	2	0229MS04	PIPE PLASTIC END PLUG
12	1	0229WE13	SUBFRAME WELDMENT
13	8	YBHH16012	BOLT HEX, 1/2 X 1 G8
14	2	0229WE12	CYLINDER BASE MOUNT WELDMENT
15	1	0229WE01	FRAME WELDMENT
16	2	0229WE03	HINGE PIN
17	2	BFR28	STRAIGHT GREASE ZERK, 1/8
18	2	0229WE07	LID LATCH RH
*	2	0229WE20	LID LATCH LH
19	4	0229WE08	DOOR HOOK
20	4	GM370	HANDLE GRIP, 1-1/2 X 4
21	4	YNNY08005	NUT HEX, NYLON LOCKNUT, 1/4
22	4	YNNY12005	NUT NYLOCK, 3/8 G5
23	4	1022	RUBBER BUMPER
24	2	0229AS03	LATCH LH
*	2	0229AS08	LATCH RH

***MEANS NOT SHOWN**

FIGURE 22 COVER HYDRAULICS

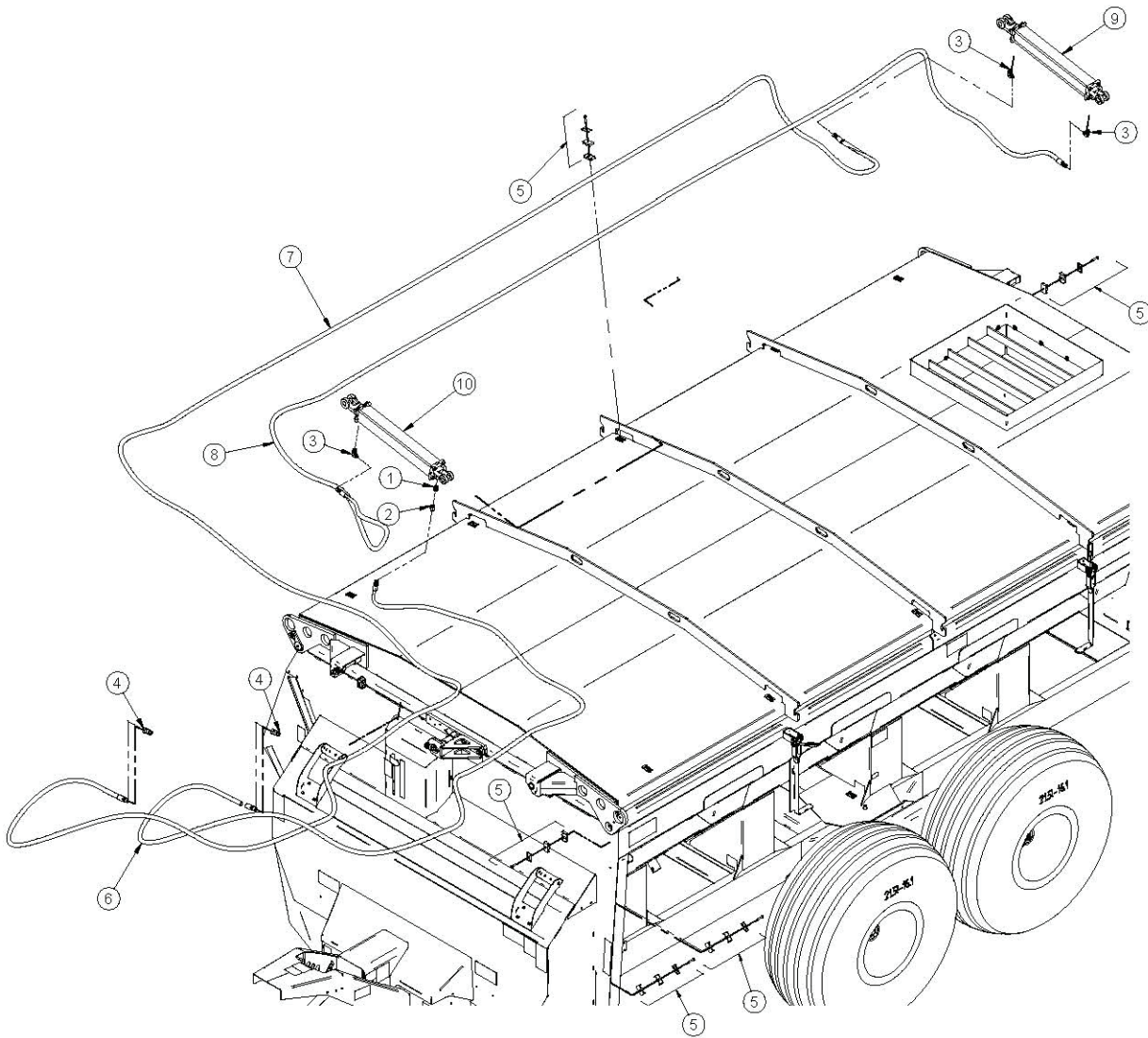

FIGURE 22

COVER HYDRAULICS

<u>ITEM</u>	<u>QTY</u>	<u>PART#</u>	<u>DESCRIPTION</u>
1	1	CHM207	STRAIGHT FITTING, 3/8 X 3/4 16 ORB
2	1	58143	06-06 M/F ORIFICE, 0.047
3	3	CHM206	FITTING, 06 90 DEG TO 3/4-16 ORB
4	2	DWM205	QUICK COUPLING MALE
5	12	CHM270	TWO HOSE CLAMP, 3/8
6	1	0229MS07	HOSE, TRACTOR TO BASE
7	1	0229MS08	HOSE, ROD TO TRACTOR REAR
8	1	0229MS09	HOSE, FRONT ROD TO REAR BASE
9	1	1020	STROKE SLAVE CYLINDER, 3 X 20
*	-	8266	SLAVE CYLINDER SEAL KIT
10	1	1019	STROKE MASTER CYLINDER, 3-1/4 X 20
*	-	8267	MASTER CYLINDER SEAL KIT

***MEANS NOT SHOWN**

FIGURE 23
COVER SEAL

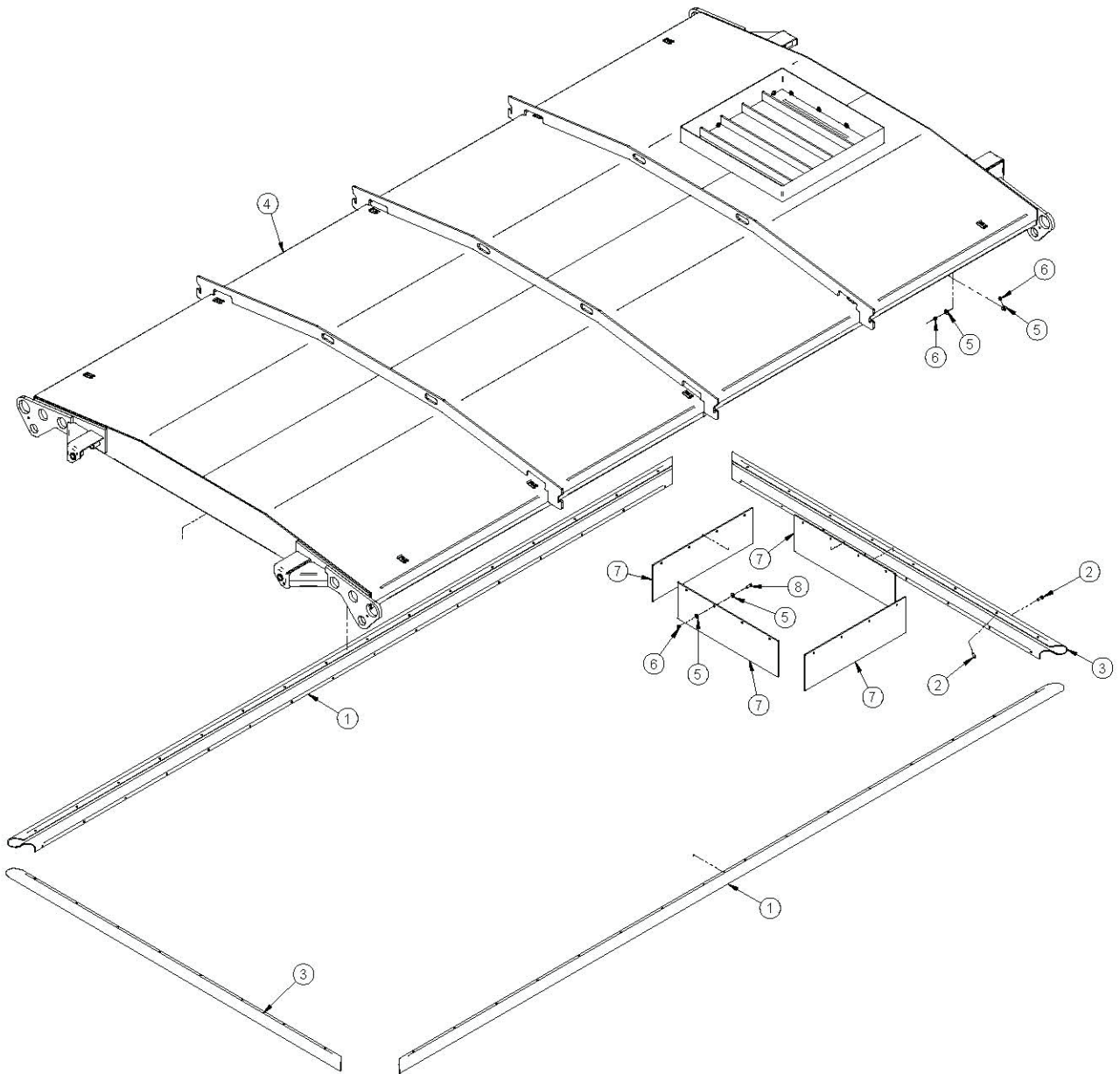

FIGURE 23 COVER SEAL

<u>ITEM</u>	<u>QTY</u>	<u>PART#</u>	<u>DESCRIPTION</u>
1	2	0229MS03	SEAL BELT, LONG
2	96	YBCR12010	BOLT CARRIAGE, 3/8 X 1 G5
3	2	0229MS02	SEAL BELT, SHORT
4	1	0229WE01	FRAME
5	128	YWFL12005	WASHER FLAT, 3/8 G5
6	112	YNNY12005	NUT HEX, NYLON LOCKNUT, 3/8
7	4	0229MS05	BELTING, CHUTE
8	16	YBHH12010	BOLT HEX, 3/8 X 1 G5

FIGURE 24 OPTIONAL TIRE & WHEEL

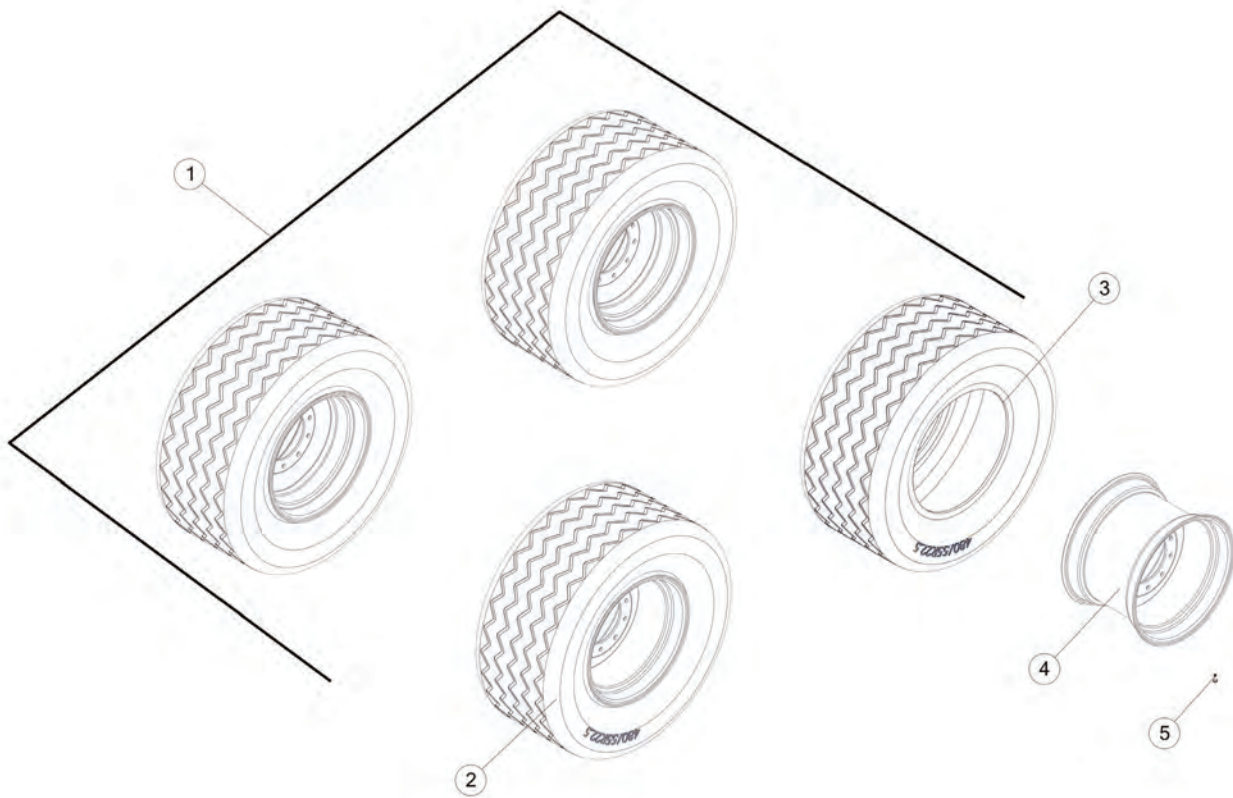

FIGURE 24
OPTIONAL TIRE & WHEEL

<u>ITEM</u>	<u>QTY</u>	<u>PART#</u>	<u>DESCRIPTION</u>
1	1	TWP480	480/55R TIRE, 22.5 X AG16 10 BLT WHL
2	4	77559	480/55 TIRE, 22.5 X AG16 10 BLT WHL
3	4	77558	TIRE, 480/55R22.5
4	4	77546	WHEEL, 22.5 X AG16 10 HOLE (OFF-WHITE)
5	4	72436	VALVE STEM RUBBER, 1-1/2

FIGURE 25
OPTIONAL TIRE & WHEEL HEAVY AXLES

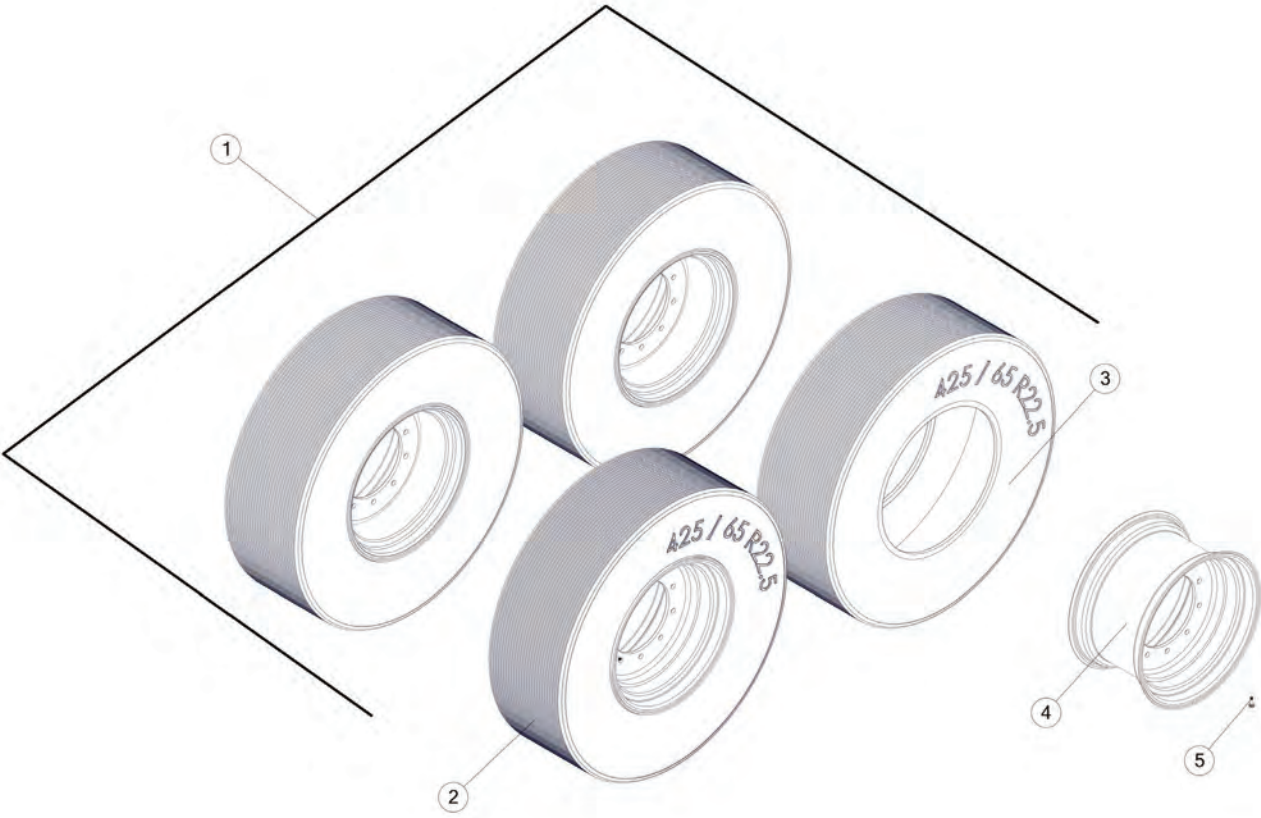

FIGURE 25
OPTIONAL TIRE & WHEEL HEAVY AXLES

<u>ITEM</u>	<u>QTY</u>	<u>PART#</u>	<u>DESCRIPTION</u>
1	1	TWP425H	USED TRUCK TIRE, 4.25 X 22.5 10 BOLT
2	4	77168	TIRE 425 X 22.5 ON WHEEL 22.5 X 13 - 10 BOLT
3	4	16SV88	TIRE, 425 X 22.5
4	4	77167	WHEEL, 22.5 X 13 10 BOLT
5	4	72436	VALVE STEM RUBBER, 1-1/2

FIGURE 26 **DISCHARGE DEFLECTOR HYDRAULIC**

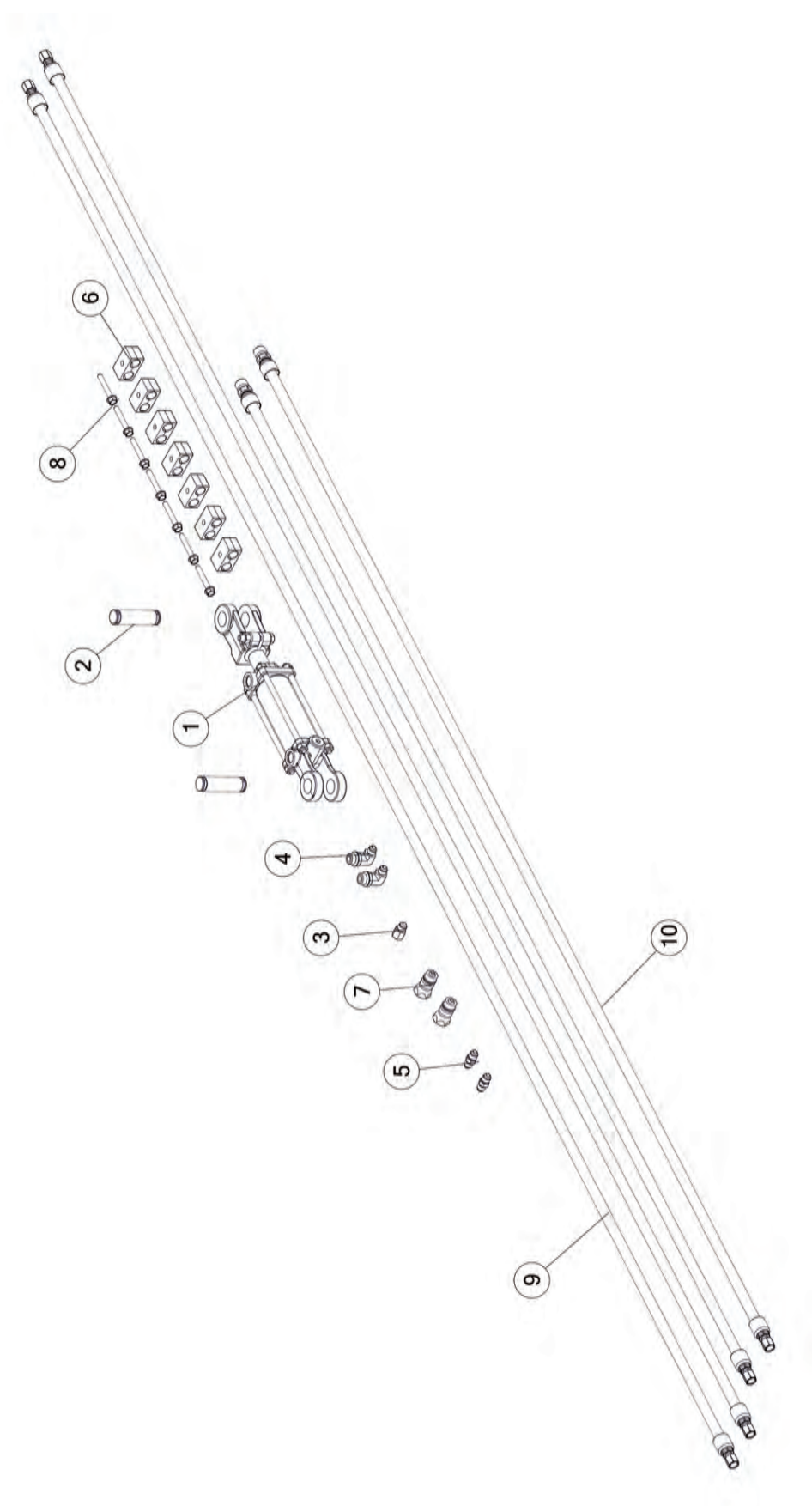

FIGURE 26
DISCHARGE DEFLECTOR HYDRAULIC

<u>ITEM</u>	<u>QTY</u>	<u>PART#</u>	<u>DESCRIPTION</u>
1	1	70797	CYLINDER, HYDRAULIC, 10.2 X 14.2
*	1	72161	SEAL KIT
2	2	72160	ASSEM, 2 CYL TIE ROD
3	1	58142	IN-LINE CONNECTOR, ORIFICE, 6-XHX7-S .031
4	2	CHM206	06 90 DEG TO 3/4-16 ORB FITTING
5	2	CHM258	FITTING ST, 6 JIC, 6 JIC
6	7	CHM278	3/8 TWO LINE CLAMP BLOCK
7	2	DWM205	VMI - MALE QUICK COUPLER S71-4P SAFEWAY HYD TIP
8	7	YBFB10225	BOLT FLG, 5/16 X 2-1/4 G5
9	2	85446	HYDRAULIC HOSE, 6, 127 IN
10	2	85664	HYDRAULIC HOSE, 6, 94 IN

*MEANS NOT SHOWN

FIGURE 27
ELECTRIC VALVE FOR DISCHARGE DEFLECTOR HYD.CYL.

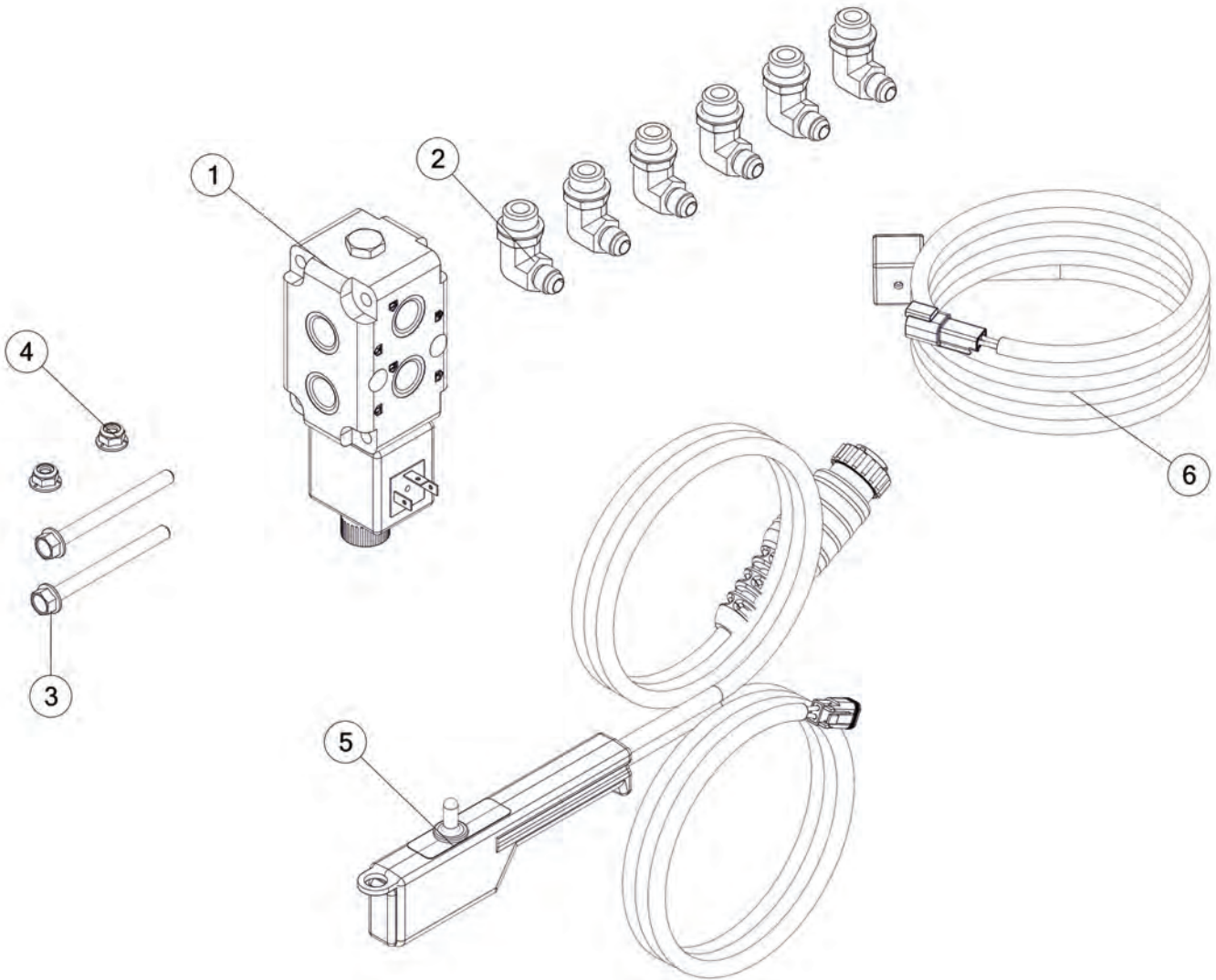

FIGURE 27

ELECTRIC VALVE FOR DISCHARGE DEFLECTOR HYD.CYL.

<u>ITEM</u>	<u>QTY</u>	<u>PART#</u>	<u>DESCRIPTION</u>
1	1	FR81	SOLENOID SELECTOR VALVE
2	6	CHM206	06 90 DEG TO 3/4-16 ORB FITTING
3	2	YBFB10350	BOLT FLANGE, 5/16 X 3-1/2 G8
4	2	YNFG10005	NUT FLANGE, 5/16 GF
5	1	85397	HAND CONTROLLER, (ON)-OFF
6	1	56138	10' DIN TO 2 PIN FEMALE DEUTSCH CORD

CHANGE NOTES

1. Replace TS54 with 84592, TS57 with 84594 on Fig 4.
2. Replace TS249 with 85430, TS250 with 85664, TS136 with CHM232, TS139 with CHM242, TS299 with 73993, GM69 with 56564, GM70 with 56596, TS197 with 57142. Removed TS253, TS117, GM9. Added 58127, CHM278, 56563, YBFB10225, YBFB10300, YNFG10005, CHM258, 70797 and 85446. On Fig 8
3. Added Fig 26 and Fig 27.

H&S MFG. CO.

products approved

for the

FEMA

SEAL OF QUALITY

