



5242
TOP SHOT
MANURE SPREADER
PARTS BOOK

Part # 72857 HSMFG081021 Rev. #04 Starting Ser. #222TS42001

STRONG HERITAGE - STRONG PEOPLE - STRONGER FUTURE

CONTENTS

Instructions for Ordering Parts - About Improvements	1
Figure 1 - Auger/Liner/Slides/Hitch	2-5
Figure 2 - Auger/Expeller Drive	6-9
Figure 3 - Expeller/Discharge Gate/Bearings	10-11
Figure 4 - Expeller/Discharge Gate/Door	12-13
Figure 5 - Expeller/Discharge Gate/Pan	14-15
Figure 6 - Guards/Shields	16-17
Figure 7 - Splash Guards/Rails	18-19
Figure 8 - Hydraulics	20-21
Figure 9 - Tandem Axles	22-23
Figure 10 - Oiler Kit	24-25
Figure 11 - Front Grease Lines	26-27
Figure 12 - Lighting	28-29
Figure 13 - Auger	30-31
Figure 14 - Gear Box	32-33
Figure 15 - Auger Front & Rear Hydraulic Cylinder	34-35
Figure 16 - Expeller Door Hydraulic Cylinder	36-37
Figure 17 - PTO (1000Rpm 1-3/8)	38-39
Figure 18 - PTO (1000Rpm1-3/4)	40-41
Figure 19 - Scale	42-43
Figure 20 - Cover Components	44-45
Figure 21 - Cover Hydraulics	46-47
Figure 22 - Cover Seal	48-49
Figure 23 - Optional Brakes	50-55
Figure 24 - Discharge Deflector Hydraulic	56-57
Figure 25 - Electric Valve for Discharge Deflector Hydraulic Cylinder	58-59
Parts Notes	60

INSTRUCTIONS FOR ORDERING PARTS

All service parts should be ordered through your authorized H&S dealer. He will be able to give you faster service if you will provide them with the following:

1. Model & Serial Number - Both can be located on the front main frame, below the PTO.
2. All references to left or right apply to the machine as viewed from the rear.
3. Parts should not be ordered from illustration only. Please order complete part number.
4. If your dealer has to order parts - give shipping instructions:

VIA truck - large pieces (please specify local truck lines)

VIA United Parcel Service (include full address)

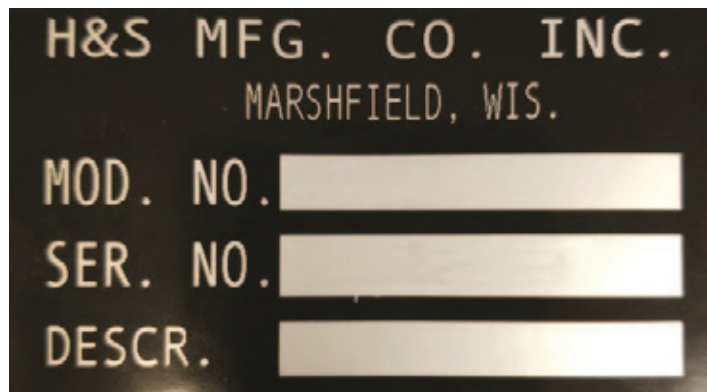

PLEASE RECORD NUMBERS FOR YOUR UNIT FOR QUICK REFERENCE

ABOUT IMPROVEMENTS

H&S IS CONTINUALLY STRIVING TO IMPROVE ITS PRODUCTS

We must, therefore, reserve the right to make improvements or changes whenever it becomes practical to do so, without incurring any obligation to make changes or additions to the equipment previously sold.

FIGURE 1 AUGER/LINER/SLIDES/HITCH

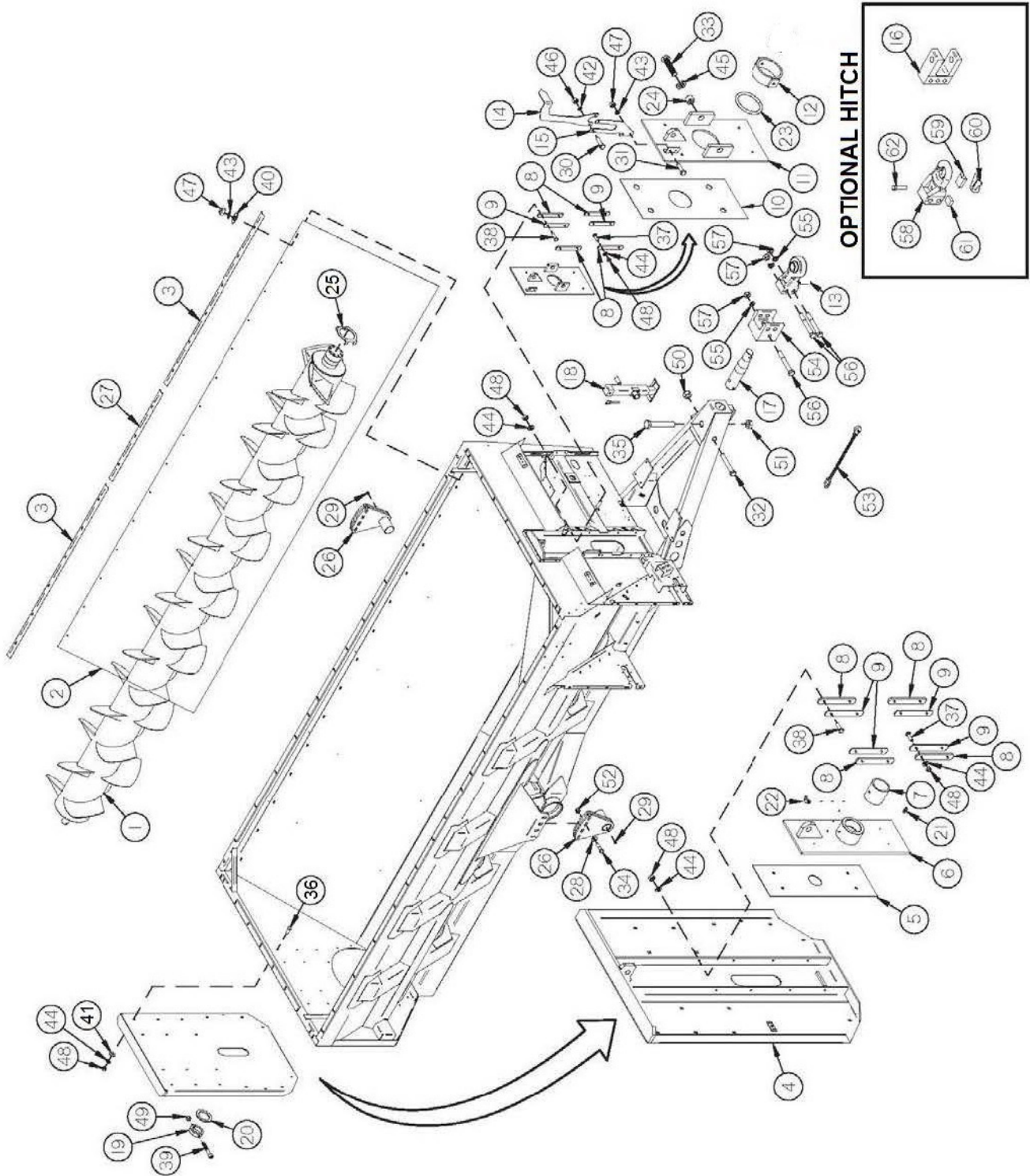

FIGURE 1

AUGER/LINER/SLIDES/HITCH

<u>ITEM</u>	<u>QTY</u>	<u>PART#</u>	<u>DESCRIPTION</u>
1	1	APX4WE01	AUGER
2	1	APX4PL01	TUB SIDE POLY
3	1	TS4	POLY TOP HOLD DOWN
4	1	TS202	BACK PANEL
5	1	TS7	BACK SLIDER POLY
6	1	TS309	BACK SLIDER
7	1	TS9	REAR AUGER BUSHING
8	8	TS10	SLIDER GUIDE
9	6	TS308	SLIDER GUIDE THIN
10	1	TS203	FRONT POLY SLIDE
11	1	TS204	FRONT SLIDE PLATE
12	1	TS400	TRUNNION HOUSING W/BEARING
13	1	58290	ARTICULATING HITCH
14	1	TS207	AUGER INDICATOR TOP
15	1	TS208	AUGER INDICATOR BOTTOM
16	1	56310	TOP SHOT HEAVY CLEVIS
17	1	TS210	HITCH BAR STRAIGHT
18	1	TS306	JACK, SIDE WIND, 7000 LBS.
19	1	TS19	AUGER BACK COLLAR
20	A/R	TS227	SPACER 2-17/32 (THICK)
*	A/R	TS28	SPACER 2-17/32 (THIN)
21	4	G89	GREASE ZERK 1/4
22	1	RG51	GREASE ZERK 90 DEGREE
23	1	TS229	RUBBER RING, 6
24	3	TS230	BUSHING, 3/4 X 7/8
25	1	TS320	WEAR PLATE 6 INCH
26	2	APX4WE02	AXLE SUPPORT OUTER
27	1	APX410G03	POLY TOP HOLD DOWN
28	8	YWFL32005	WASHER FLAT, 1 SAE
29	2	BFR28	GREASE ZERK, 1/8
30	2	YBHH08100	BOLT HEX, 1/4 X 3/4 G5
31	2	YBHH10105	BOLT HEX, 5/16 X 3/4 G5
32	1	YBHH20101	BOLT HEX, 5/8 X 6 G8
33	2	YBHH24018	BOLT HEX, 3/4-10 X 2 G8
34	8	YBHH32018	BOLT HEX, 1-8 X 4 G8
35	1	YBHH32026	BOLT HEX, 1 X 6 G8
36	20	YBCR12010	BOLT CARRIAGE, 3/8 X 1 G5
37	8	YBCR12020	BOLT CARRIAGE, 3/8 X 1-1/4 G5
38	8	YBCR12015	BOLT CARRIAGE, 3/8 X 1-1/2 G5
39	1	YSHS12018	SCREW SOCKET HEAD CAP, 3/8 X 4
40	15	YWFL10005	WASHER FLAT, 5/16
41	20	YWFL12005	WASHER FLAT, 3/8
42	2	YWLO08005	WASHER LOCK, 1/4
43	17	YWLO10005	WASHER LOCK, 5/16
44	36	YWLO12005	WASHER LOCK, 3/8
45	2	YWLO24005	WASHER LOCK, 3/4

***MEANS NOT SHOWN
A/R MEANS AS REQUIRED**

FIGURE 1 AUGER/LINER/SLIDES/HITCH

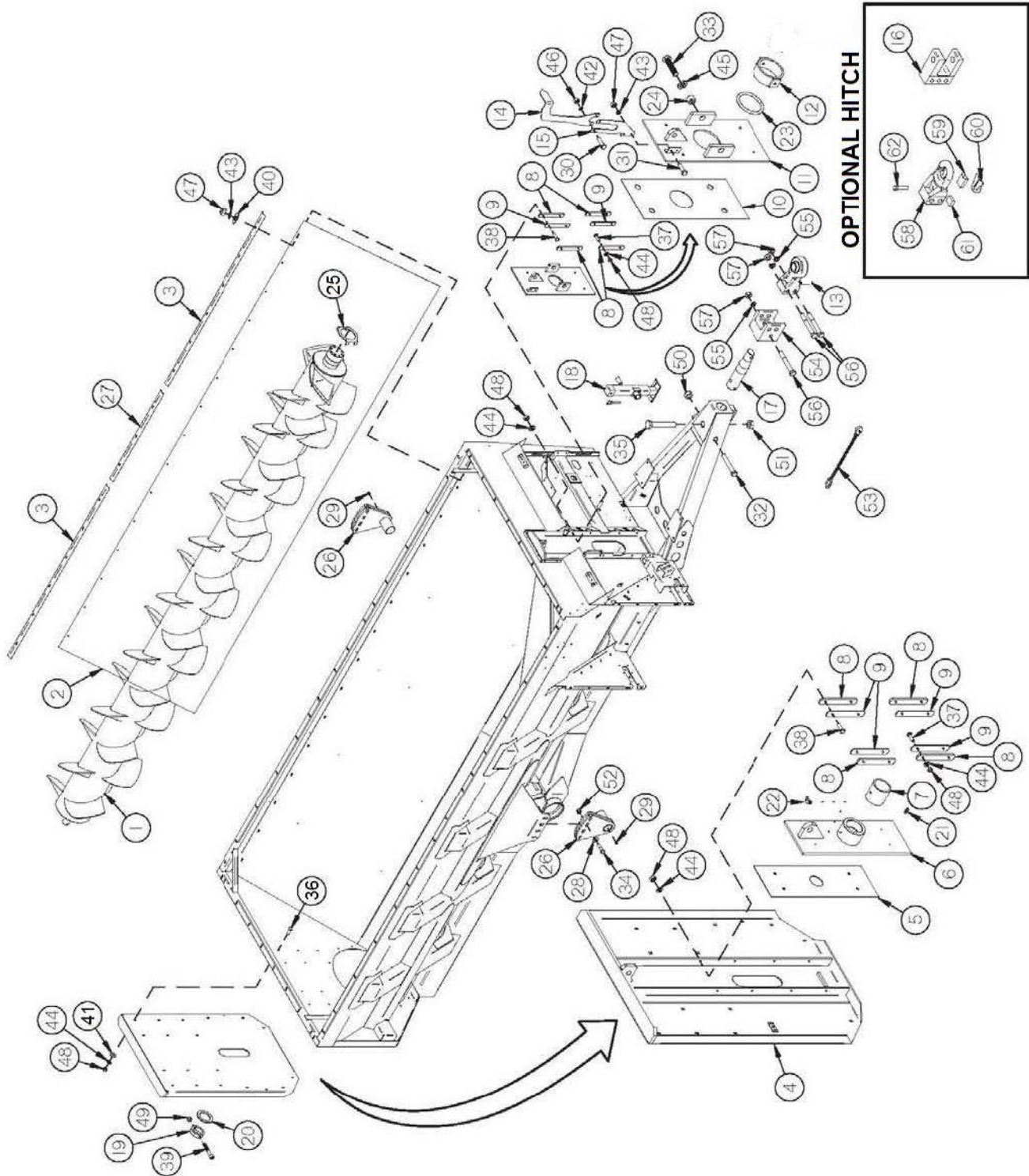

FIGURE 1

AUGER/LINER/SLIDES/HITCH

<u>ITEM</u>	<u>QTY</u>	<u>PART#</u>	<u>DESCRIPTION</u>
46	2	YNHX08005	NUT HEX, 1/4-20
47	17	YNHX10005	NUT HEX, 5/16
48	36	YNHX12005	NUT HEX, 3/8-16
49	1	YNL12005	NUT HEX, TOP LOCK, 3/8-16
50	1	YNRL20005	NUT HEX, REVERSIBLE-SIDE LOCK, 5/8-11
51	1	YNRL32005	NUT HEX, REVERSIBLE-SIDE LOCK, 1-8
52	8	YNL32005	NUT HEX, TOP LOCK, 1
53	1	SC60000	SAFETY CHAIN #60000 (OPTIONAL)
54	1	APX3HF41	HITCH ADAPTER
55	3	YWLO32005	WASHER LOCK, 1
56	3	YBHH32034	BOLT HEX, 1-8 X 7-1/2 G8
57	3	YNHX32015	NUT HEX, 1- 8 G8
58	1	58557	BASE, PERFECT HITCH
59	1	58558	V BLOCK
60	1	58559	PLATE, TOP
61	1	58554	CUSHION
62	1	YBHH24051	BOLT HEX, 3/4 X 3 G5

FIGURE 2 **AUGER/EXPELLER DRIVE**

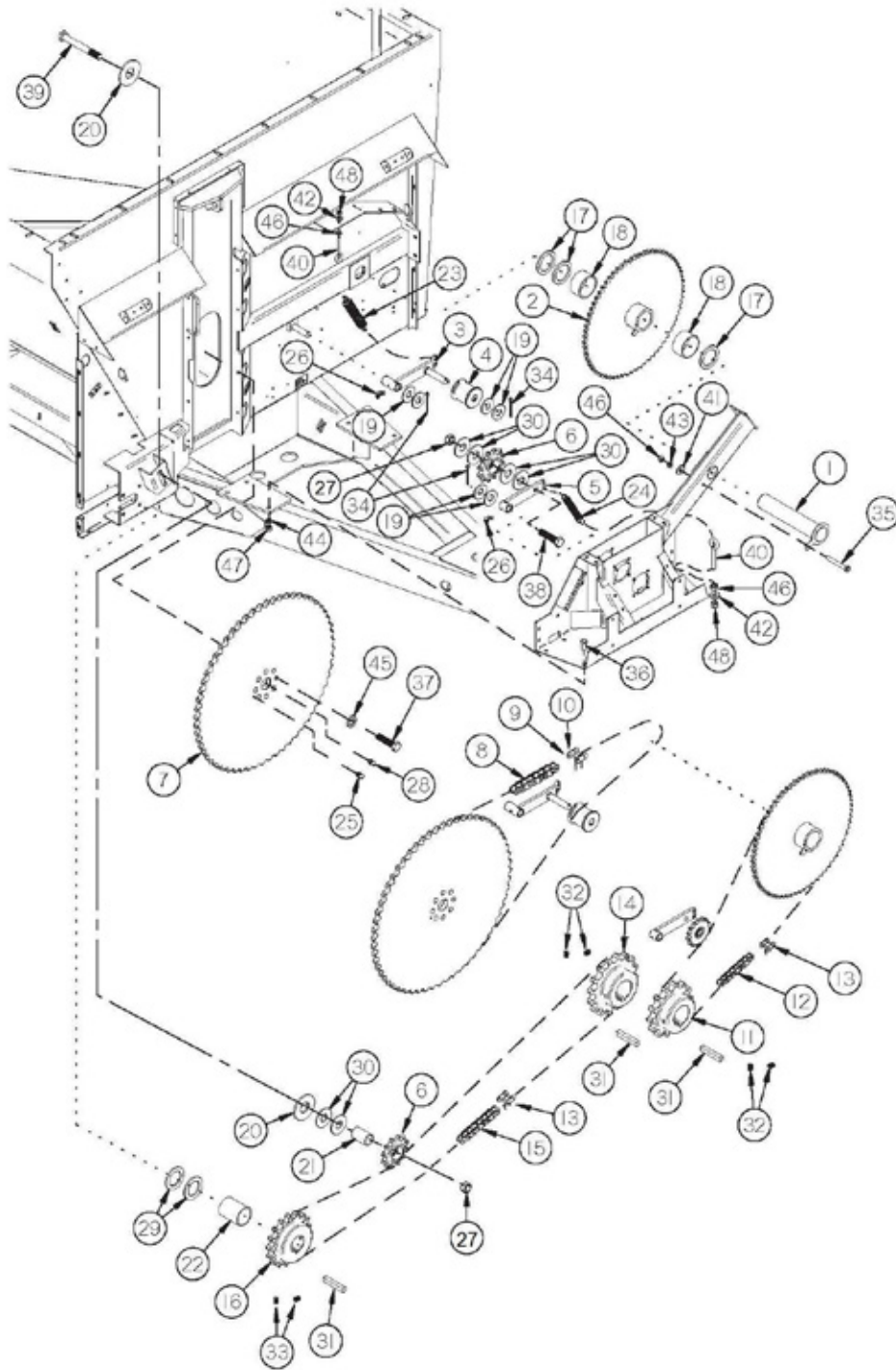

FIGURE 2

AUGER/EXPELLER DRIVE

<u>ITEM</u>	<u>QTY</u>	<u>PART#</u>	<u>DESCRIPTION</u>
1	1	TS211	COUNTER SHAFT
2	1	TS212	COUNTER SHAFT REDUCTION
3	1	TS213	AUGER CHAIN TENSIONER
4	1	TS25	ROLLER IDLER
5	1	TS214	CHAIN TENSIONER
6	2	16SV328	SPROCKET W/SNAP RING AND BEARING
7	1	TS217	SPROCKET
8	1	TS218	ROLLER CHAIN (#140HE)
9	1	TS219	OFFSET LINK (#140HE)
10	1	TS220	CONNECTOR LINK (#140HE)
11	1	TS221	DRIVE SPROCKET, #80X14T (STANDARD, FACTORY)
*	1	TS372	DRIVE SPROCKET, #80X12T (OPTIONAL, FIELD)
*	1	TS373	DRIVE SPROCKET, #80X15T (OPTIONAL, FIELD)
*	1	TS224	DRIVE SPROCKET, #80X16T (OPTIONAL, FIELD)
12	1	TS222	ROLLER CHAIN, #80HE X 98 (14T & 15T SPRCKT, FACTORY)
*	1	TS375	ROLLER CHAIN, #80HE X 97 (12T SPROCKET, FIELD)
*	1	TS376	ROLLER CHAIN, #80HE X 99 (16T SPROCKET, FIELD)
13	2	TS223	CONNECTOR LINK, (#80HE)
14	1	TS224	SPROCKET, #80X16T (STANDARD, FACTORY)
*	1	TS372	SPROCKET, #80X12T (OPTIONAL, FIELD)
*	1	TS221	SPROCKET, #80X14T (OPTIONAL, FIELD)
15	1	TS225	ROLLER CHAIN, #80HE X 84 (16T SPROCKET, FACTORY)
*	1	TS379	ROLLER CHAIN, #80HE X 82 (12T SPROCKET, FIELD)
*	1	TS380	ROLLER CHAIN, #80HE X 83 (14T SPROCKET, FIELD)
16	1	TS226	SPROCKET, 80B17
17	A/R	TS227	SPACER, 2-17/32 (THICK)
*	A/R	TS28	SPACER, 2-17/32 (THIN)
18	2	73576	WASHER FLAT, SAE 1 ZINC
19	A/R	YWFL32005	SPACER, 1
20	2	16SV376	SPACER
21	3	TS230	TRUNION PIVOT BUSHING, 3/4 X 7/8 X 1-1/4
22	1	TS231	SPACER
23	1	BFR138	SPRING
24	1	K103	SPRING/EXTENSION
25	1	G89	STRAIGHT ZERK, 1/4 X 90
26	2	RG51	GREASE ZERK, 1/4 - 28 90 DEGREE
27	2	YNRL24005	NUT HEX, REVERSIBLE-SIDE LOCK, 3/4
28	1	BFR28	GREASE ZERK, 1/8
29	A/R	S36	SHIM, 3/16
*	A/R	S409	SHIM, 1/8
30	6	T73	WASHER

***MEANS NOT SHOWN**

A/R MEANS AS REQUIRED

FIGURE 2

AUGER/EXPELLER DRIVE

<u>ITEM</u>	<u>QTY</u>	<u>PART#</u>	<u>DESCRIPTION</u>
31	3	G139	SQUARE KEY, 3/8 X 1-1/2
32	4	YSKP12025	SCREW SET SOCKET, KNURLED CUP PT, 3/8 X 3/8
33	2	YSKP12010	SCREW SET SOCKET, KNURLED CUP PT, 3/8 X 1/2
34	3	YPCT05010	COTTER PIN, 5/32 X 1-1/2
35	1	YBHH12110	BOLT HEX, 3/8 X 2-3/4 G5
36	6	YBHH20010	BOLT HEX, 5/8 X 1-1/2 G5
37	8	YBHH24041	BOLT HEX, 3/4 X 2-3/4 G8
38	1	YBHH24050	BOLT HEX, 3/4 X 3 G5
39	1	YBHH24075	BOLT HEX, 3/4 X 4-1/2 G5
40	2	YBTE12025	BOLT TURNED EYE, 3/8 X 3
41	1	YWFL10005	WASHER FLAT, 5/16
42	1	YWFL12005	WASHER FLAT, 3/8
43	1	YWLO12005	WASHER LOCK, 3/8
44	6	YWLO20005	WASHER LOCK, 5/8
45	8	YWLO24005	WASHER LOCK, 3/4
46	3	YNHX12005	NUT HEX, 3/8
47	6	YNHX20005	NUT HEX, 5/8
48	2	YNNY12005	NUT HEX, NYLON LOCKNUT, 3/8 G2

FIGURE 3 **EXPELLER/DISCHARGE GATE/BEARINGS**

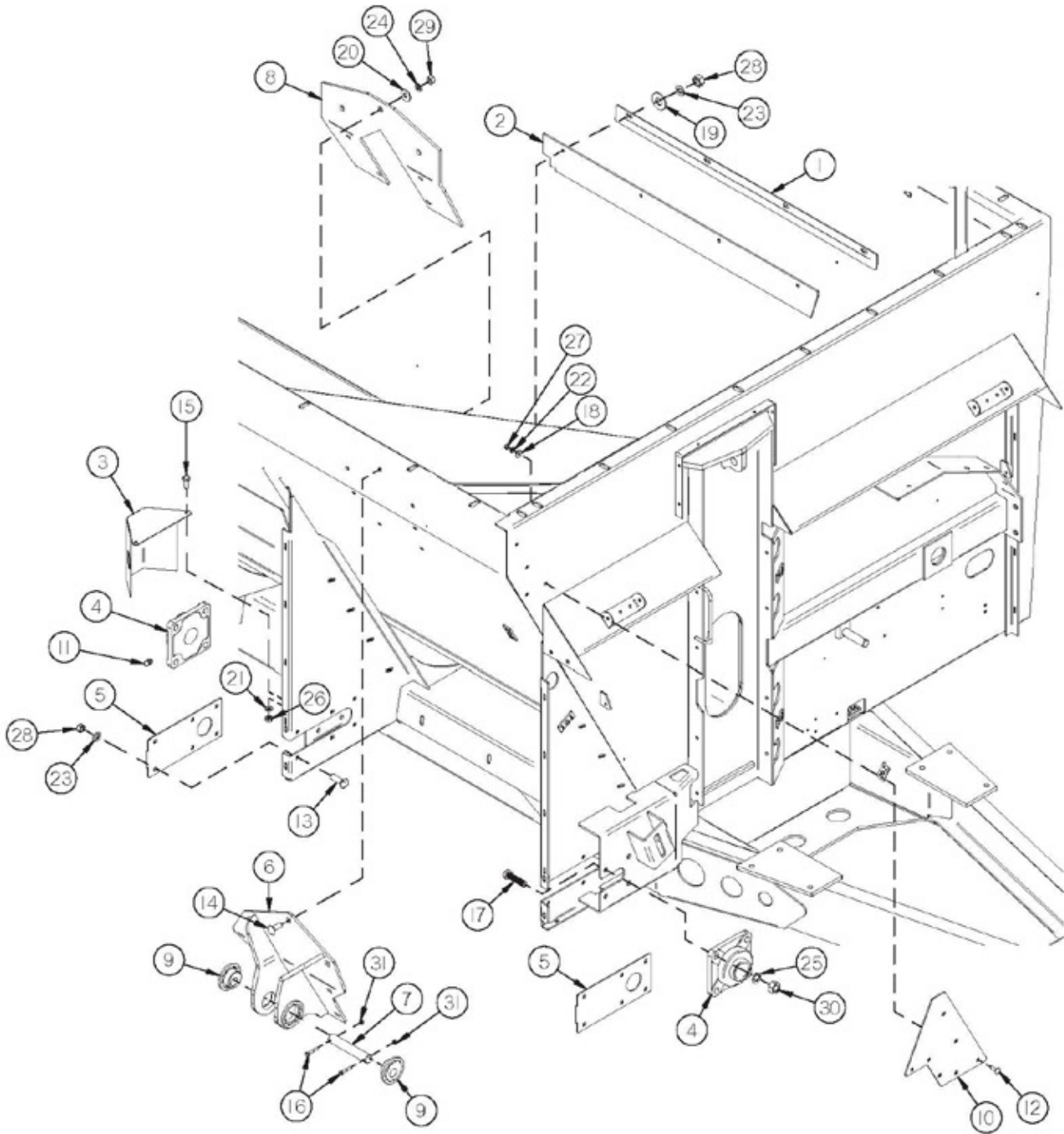

FIGURE 3

EXPELLER/DISCHARGE GATE/BEARINGS

<u>ITEM</u>	<u>QTY</u>	<u>PART#</u>	<u>DESCRIPTION</u>
1	1	TS43	DOOR SEAL CLAMP
2	1	TS44	EXPELLER DOOR TOP SEAL
3	1	TS45	EXPELLER BEARING SHIELD
4	2	HGV41	EXPELLER BEARING
5	2	TS47	COVER PLATE
6	1	APX3WE69	CYL MOUNT SUB WELD
7	1	APX3SH15	DOOR CYL TOP PIN
8	1	APX33G52	DOOR CYL REINFORCEMENT
9	2	DWM314	HEX PLUG
10	1	APX310G66	BOLT ON INDICATOR MOUNT
11	1	G89	STRAIGHT GREASE ZERK, 1/4 X 90
12	4	YBCR10010	BOLT CARRIAGE, 5/16 X 1 G5
13	12	YBCR12010	BOLT CARRIAGE, 3/8 X 1 G5
14	7	YBCR16010	BOLT CARRIAGE, 1/2 X 1-1/2 G5
15	2	YBHH08100	BOLT HEX, 1/4 X 3/4 G5
16	2	YBHH08025	BOLT HEX, 1/4 X 1-1/2 G5
17	8	YBHH18010	BOLT HEX, 9/16 X 1-3/4 G5
18	4	YWFL06010	WASHER FLAT, 3/16
19	4	YWFL12005	WASHER FLAT, 3/8
20	7	YWFL16005	WASHER FLAT, 1/2
21	2	YWLO08005	WASHER LOCK, 1/4
22	4	YWLO10005	WASHER LOCK, 5/16
23	16	YWLO12005	WASHER LOCK, 3/8
24	7	YWLO16005	WASHER LOCK, 1/2
25	8	YWLO18005	WASHER LOCK, 9/16
26	2	YNHX08005	NUT HEX, 1/4
27	4	YNHX10005	NUT HEX, 5/16
28	16	YNHX12005	NUT HEX, 3/8
29	7	YNHX16005	NUT HEX, 1/2
30	8	YNHX18005	NUT HEX, 9/16
31	2	YNTL08005	NUT HEX, TOP LOCK, 1/4

FIGURE 4
EXPELLER/DISCHARGE GATE/DOOR

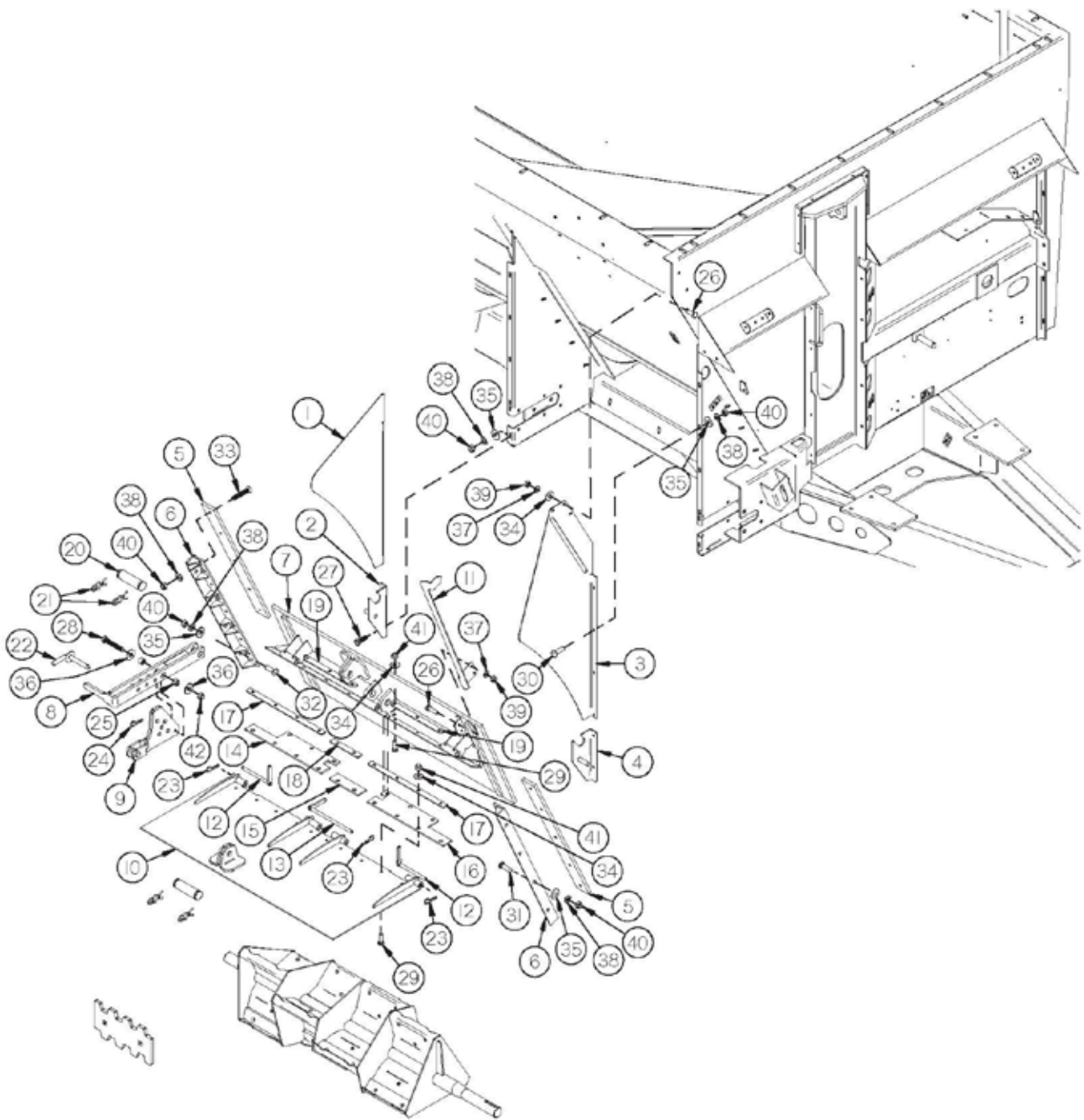

FIGURE 4

EXPPELLER/DISCHARGE GATE/DOOR

<u>ITEM</u>	<u>QTY</u>	<u>PART#</u>	<u>DESCRIPTION</u>
1	1	TS232	EXPPELLER SPOUT LH
2	1	TS49	PAN HINGE BRACKET LH
3	1	TS233	EXPPELLER SPOUT RH
4	1	TS51	PAN HINGE BRACKET RH
5	2	TS52	DOOR SLIDER POLY
6	2	TS53	EXPPELLER DOOR GUIDE
7	1	84592	EXPPELLER DOOR
8	1	TS55	DEFLECTOR ADJUSTMENT HANDLE
9	1	TS56	DEFLECTOR ADJUSTMENT LINK
10	1	84594	ADJUSTABLE FLAT DEFLECTOR
11	1	TS58	DOOR INDICATOR
12	2	TS59	DEFLECTOR SIDE PIN
13	1	TS60	DEFLECTOR MID PIN
14	1	TS61	DEFLECTOR SEAL LH
15	1	TS62	MID DEFLECTOR SEAL
16	1	TS63	DEFLECTOR SEAL RH
17	2	TS64	SEAL STRAP LONG
18	1	TS65	SEAL STRAP MID
19	2	TS66	SEAL STRAP SHORT
20	2	T143	CYLINDER PIN
21	4	YPHR02020	HAIR PIN
22	1	TS69	CASTER LOCKING PIN
23	3	X97	HAIR PIN
24	1	WM378	HAIR PIN W/LANYARD
25	2	TS307	HANDLE PIVOT
26	5	YBHH10105	BOLT HEX, 5/16 X 3/4 G5
27	4	YBHH12010	BOLT HEX, 3/8 X 1 G5
28	1	YBHH16105	BOLT HEX, 1/2 X 3 G5
29	16	YBCR10010	BOLT CARRIAGE, 5/16 X 1 G5
30	8	YBCR12010	BOLT CARRIAGE, 3/8 X 1 G5
31	7	YBCR12020	BOLT CARRIAGE, 3/8 X 1-1/4 G5
32	1	YBCR12015	BOLT CARRIAGE, 3/8 X 1-1/2 G5
33	10	YSFS12005	SCREW FLAT HEAD SOCKET CAP, 3/8 X 1-1/4
34	19	YWFL10005	WASHER FLAT, 5/16
35	20	YWFL12005	WASHER FLAT, 3/8
36	2	YWFL16005	WASHER FLAT, 1/2
37	5	YWLO10005	WASHER LOCK, 5/16
38	30	YWLO12005	WASHER LOCK, 3/8
39	5	YNHX10005	NUT HEX, 5/16
40	30	YNHX12005	NUT HEX, 3/8
41	16	YNTL10005	NUT HEX, TOP LOCK, 5/16
42	1	YNTL16005	NUT HEX, TOP LOCK, 1/2

FIGURE 5 **EXPELLER/DISCHARGE GATE/PAN**

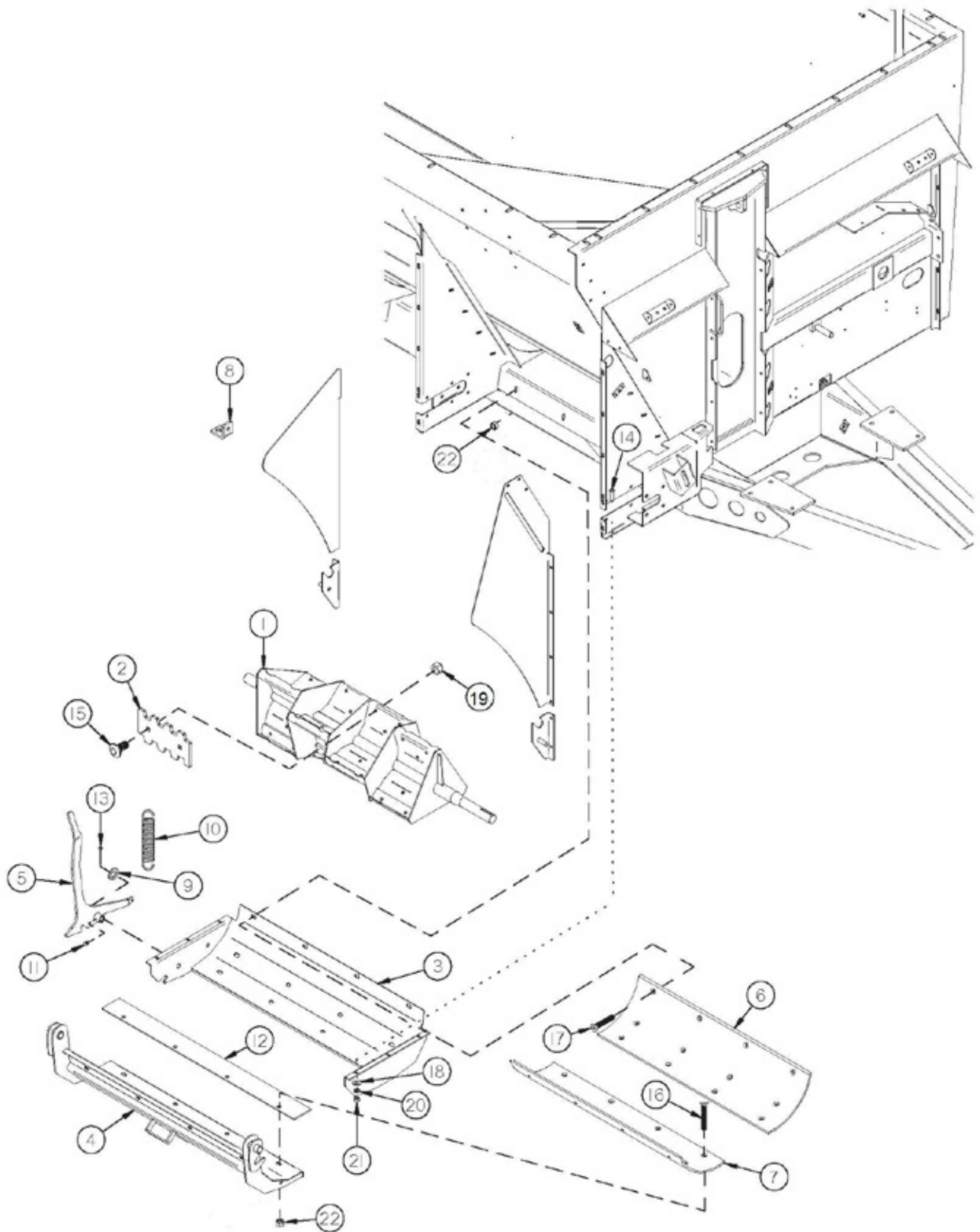

FIGURE 5

EXPELLER/DISCHARGE GATE/PAN

<u>ITEM</u>	<u>QTY</u>	<u>PART#</u>	<u>DESCRIPTION</u>
1	1	69616	EXPELLER
2	12	TS68	EXPELLER PADDLE
3	1	TS72	SWING AWAY PAN FRAME
4	1	TS73	SWING AWAY PAN
5	1	TS74	PAN LATCH HANDLE
6	1	TS75	EXPELLER BACK POLY
7	1	TS76	EXPELLER PAN POLY
8	1	56N146	SHIELD ANGLE
9	3	T73	SPACER
10	1	K103	SPRING
11	1	G89	GREASE ZERK
12	1	TS18	PAN RUBBER SEAL
13	1	YPCT06010	COTTER PIN, 3/16 X 1-1/4
14	6	YBCR10010	BOLT CARRIAGE, 5/16 X 1 G5
15	24	YBCR16019	BOLT CARRIAGE, 1/2 X 1-3/4 G8
16	20	YSFS16010	BOLT FLAT SOK, 1/2 X 1-1/2
17	4	YSFS16020	BOLT FLAT SOK, 1/2 X 1-3/4
18	6	YWFL10005	WASHER FLAT, 5/16
19	24	YNL16006	NUT HEX, TOP LOCK 1/2 G9
20	6	YWLO10005	WASHER LOCK, 5/16
21	6	YNHX10005	NUT HEX, 5/16
22	24	YNFG16003	NUT FLANGE, 1/2 GF

FIGURE 6 **GUARDS/SHIELDS**

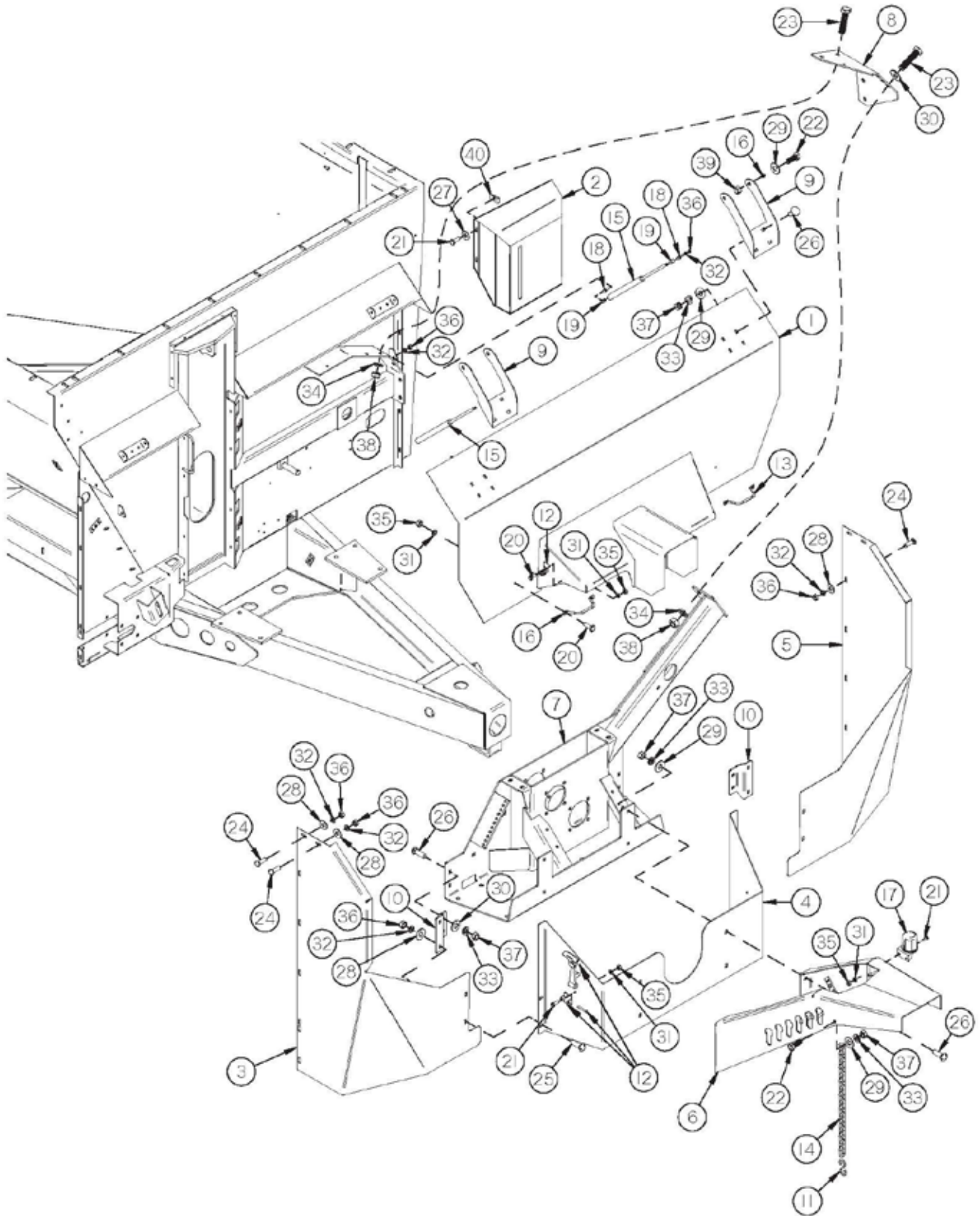

FIGURE 6

GUARDS/SHIELDS

<u>ITEM</u>	<u>QTY</u>	<u>PART#</u>	<u>DESCRIPTION</u>
1	1	TS234	SHIELD FRONT
2	1	TS235	CYLINDER COVER FRONT
3	1	TS236	RH SHIELD FRONT
4	1	TS237	GEARBOX SHIELD
5	1	TS238	LH SHIELD FRONT
6	1	TS239	HOSE HOLDER
7	1	TS240	GEARBOX
8	1	TS241	JACKSHAFT BRACE
9	8	TS242	SHIELD HINGE
10	8	TS243	FRONT SHIELD MOUNT
11	1	F87	S HOOK
12	2	X233	COMPLETE LATCH
13	2	TS96	SHIELD HANDLE
14	1	TS130	CHAIN PTO HOLDER
15	2	TS244	GAS STRUT
16	4	GM180	SPACER
17	1	CHM38	PLUG COVER
18	2	TS382	BALL MOUNT 10MM
19	2	TS383	BALL 10MM
20	6	YBHH08015	BOLT HEX, 1/4 X 1/2 G5
21	8	YBHH08100	BOLT HEX, 1/4 X 3/4 G5
22	5	YBHH12010	BOLT HEX, 3/8 X 1 G5
23	8	YBHH20010	BOLT HEX, 5/8 X 1-1/2 G5
24	8	YBCR10030	BOLT CARRIAGE, 5/16 X 3/4 G5
25	4	YBCR10010	BOLT CARRIAGE, 5/16 X 1 G5
26	16	YBCR12010	BOLT CARRIAGE, 3/8 X 1 G5
27	4	YWFL08005	WASHER FLAT, 1/4
28	12	YWFL10005	WASHER FLAT, 5/16
29	21	YWFL12005	WASHER FLAT, 3/8
30	3	YWFL20005	WASHER FLAT, 5/8
31	10	YWLO08005	WASHER LOCK, 1/4
32	16	YWLO10005	WASHER LOCK, 5/16
33	17	YWLO12005	WASHER LOCK, 3/8
34	8	YWLO20005	WASHER LOCK, 5/8
35	10	YNHX08005	NUT HEX, 1/4
36	16	YNHX10005	NUT HEX, 5/16
37	17	YNHX12005	NUT HEX, 3/8
38	8	YNHX20005	NUT HEX, 5/8
39	4	YNTL12005	NUT HEX, TOP LOCK, 3/8
40	4	YNUN08005	NUT U, EXTRUDED, 1/4

FIGURE 7 **SPLASH GUARDS/RAILS**

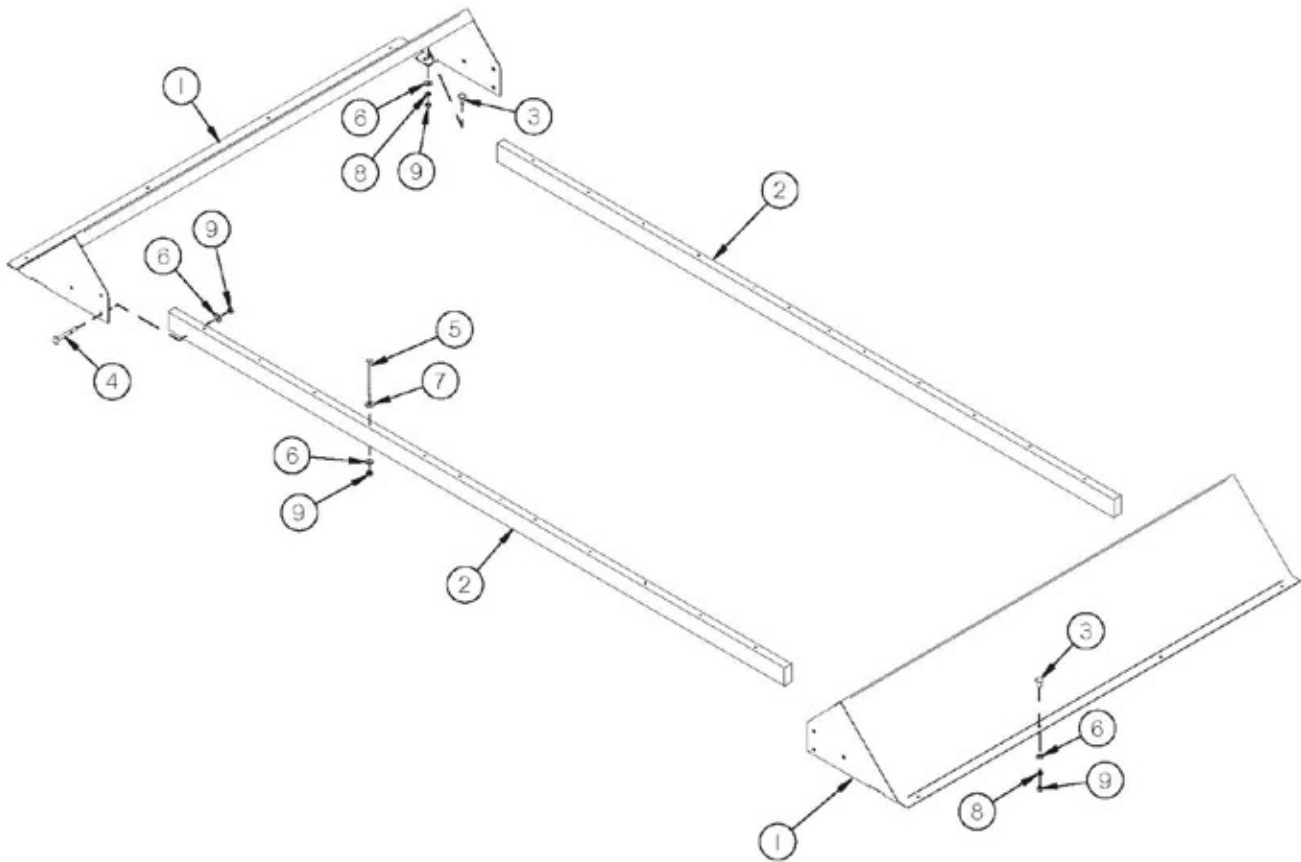

FIGURE 7
SPLASH GUARDS/RAILS

<u>ITEM</u>	<u>QTY</u>	<u>PART#</u>	<u>DESCRIPTION</u>
1	2	TS245	SPLASH GUARD
2	2	APX4MS04	WOOD RAIL
3	12	YBCR12010	BOLT CARRIAGE, 3/8 X 1 G5
4	12	YBCR12080	BOLT CARRIAGE, 3/8 X 3-1/4 G5
5	24	YBCR12123	BOLT CARRIAGE, 3/8 X 6-1/2 G5
6	48	YWFL12005	WASHER FLAT, 3/8
7	24	YWFL16005	WASHER FLAT, 1/2
8	12	YWLO12005	WASHER LOCK, 3/8
9	48	YNHX12005	NUT HEX, 3/8

FIGURE 8 HYDRAULICS

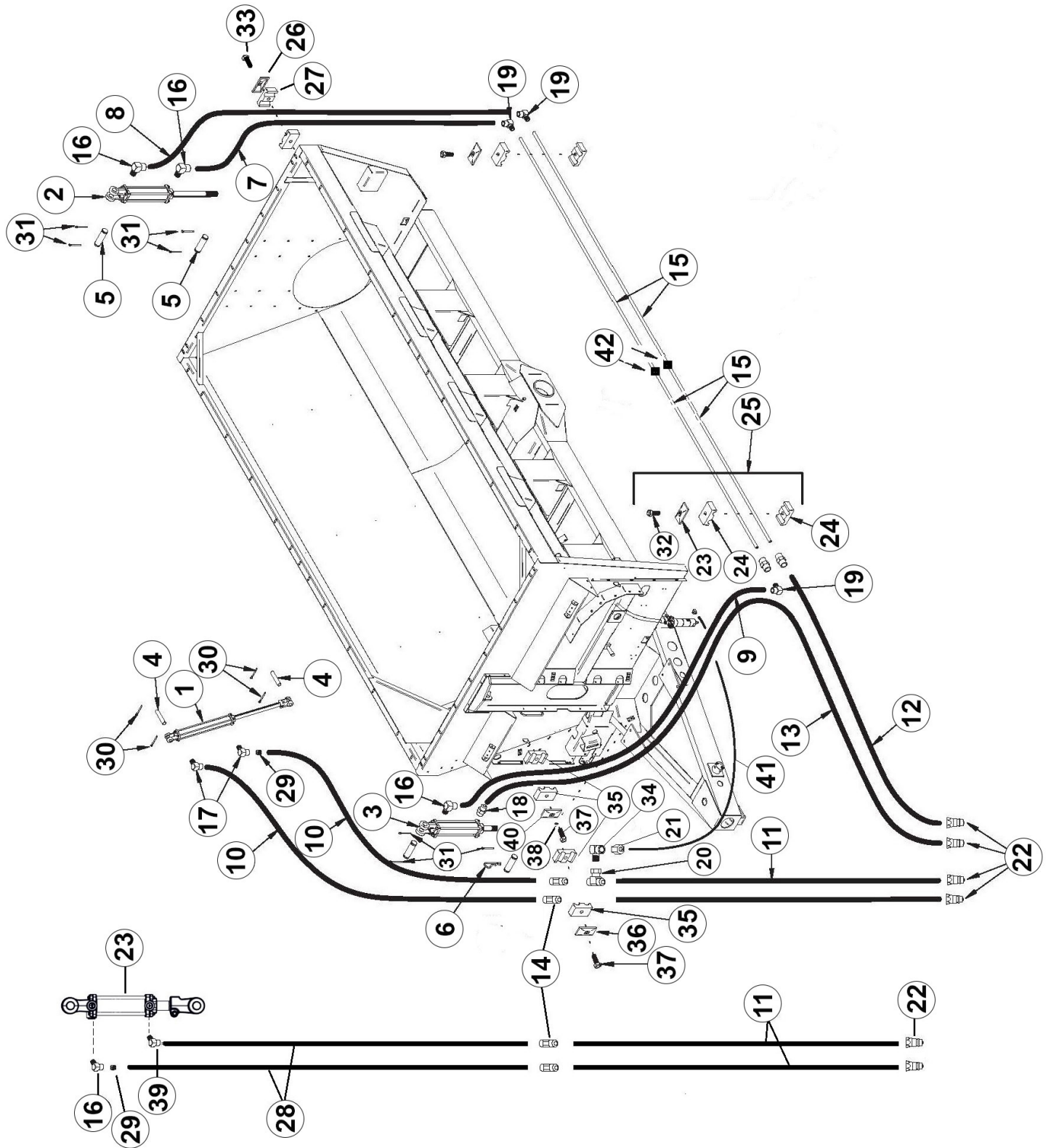

FIGURE 8 HYDRAULICS

<u>ITEM</u>	<u>QTY</u>	<u>PART#</u>	<u>DESCRIPTION</u>
1	1	23N111A	CYLINDER, 2 X 16
2	1	TS105	CYLINDER, 3-1/4 X 8
3	1	TS104	CYLINDER, 3 X 8
4	2	LW55	CYLINDER PIN
5	4	T143	CYLINDER PIN
6	1	YPHR02010	HAIR PIN, #21-07
7	1	TS115	HYDRAULIC HOSE, 1/2 X 49
8	1	TS247	HYDRAULIC HOSE, 1/2 X 60
9	1	TS248	HYDRAULIC HOSE, 1/2 X 66
10	2	85430	HYDRAULIC HOSE, 6 X 125
11	4	85664	HYDRAULIC HOSE, 6 X 94
12	1	TS251	HYDRAULIC HOSE, 1/2 X 132
13	1	TS252	HYDRAULIC HOSE, 1/2 X 184
14	4	CHM258	UNION (6 HTX-S)
15	4	89070	HYDRAULIC TUBE, 1/2 X 120
16	3	TS135	8 MALE O-RING TO -8 MALE JIC 90°
17	2	CHM232	FITTING, 90, 6JIC X 1/2NPT
18	1	TS137	8 MALE O-RING TO -8 MALE JIC
19	3	TFM83	8 FEMALE JIC SWIVEL TO -8 MALE JIC 90
20	1	CHM242	FITTING, TEE, 6JIC X 6JIC X 6JIC
21	1	73993	FITTING, ST,6JIC, 6NPTF, STL
22	6	DWM205	MALE QUICK COUPLER W/HYD TIP
23	3	70797	CYLINDER, HYDRAULIC, 10.2 X 14.2
24	6	TS118	LINE CLAMP BLOCK
25	3	TFM91	DOUBLE STEEL LINE CLAMP
26	6	56564	CLAMP TOP PLATE
27	6	56596	CLAMP CUSHION (SET OF 2)
28	2	85446	HYDRAULIC HOSE, 6 X127
29	2	58142	IN-LINE CONNECTOR, ORIFICE, 6-XHX7-S .031
30	4	YPCT05010	COTTER PIN, 5/32 X 1-1/2
31	7	YPCT06005	COTTER PIN, 3/16 X 1-1/2
32	10	56568	BOLT HEX 5/16 X 1-3/8 G5
33	6	56569	BOLT 5/16 X 1-3/4 G5
34	1	58127	FITTING 6 C6X-S
35	10	CHM278	CLAMP HALF 3/8" HOSE (SET OF 2)
36	11	56563	CLAMP TOP PLATE
37	5	56573	CLAMP STACKING BOLT
*	1	YBFB10300	BOLT FLANGE, 5/16 X 3 G5
38	1	YNFG10005	NUT FLANGE, 5/16-18, GF
39	2	CHM206	ELBOW (6-8 C50X-S)
40	5	56581	CLAMP TOP PLATE
41	1	86383	HYDRAULIC HOSE, 4, 78IN
42	2	GM17	ADAPTER (8 HTX)

***MEANS NOT SHOWN**

FIGURE 9 **TANDEM AXLES**

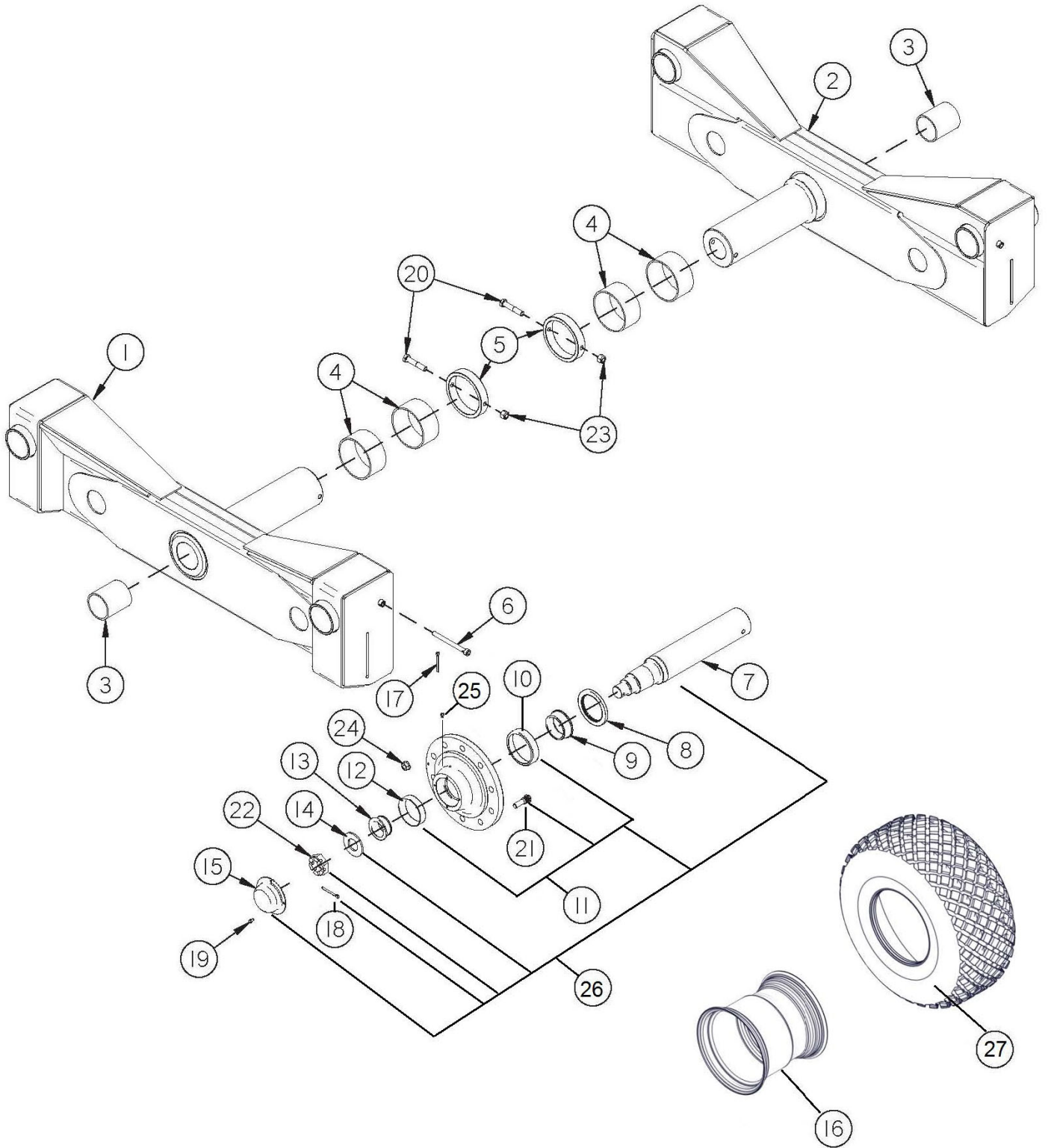

FIGURE 9 TANDEM AXLES

<u>ITEM</u>	<u>QTY</u>	<u>PART#</u>	<u>DESCRIPTION</u>
1	1	57388	DROP TANDEM BEAM RH
2	1	57394	DROP TANDEM BEAM LH
3	2	60543	BEARING, NYLATRON, 4 ID
4	4	58805	BEARING, NYLATRON, 6.5 ID
5	2	APX4TU08	TANDEM COLLAR
6	4	TS260	SPINDLE PIN
7	4	TS394	TANDEM SPINDLE (15000 LB HUB)
8	4	90298	OIL BATH SEAL
9	4	TS388	INNER BEARING
10	4	TS389	INNER RACE
11	4	90288	HUB SUB ASSEMBLY
12	4	TS390	OUTER RACE
13	4	TS391	OUTER BEARING
14	4	90290	WASHER
15	4	90291	OIL BATH CAP
16	4	8571	WHEEL
17	4	YPCT06020	COTTER PIN, 3/16 X 2
18	4	YPEX12350	EXPANSION PIN, 3/8 X 3-1/2
19	16	YBHH10105	BOLT HEX, 5/16 X 3/4 G5
20	4	YBHH20060	BOLT HEX, 5/8 X 3-1/4 G5 ZC
21	40	YBSD24015	BOLT STUD, 3/4-16UNF X 3-7/8 (3/4)
22	4	YNSL44005	NUT HEX, SLOTTED, 2-12
23	4	YNTL20005	NUT HEX, TOP LOCK, 5/8-11
24	40	BFR618	NUT FLANGE, 3/4-16
25	4	BFR28	GREASE ZERK, 1/8
26	4	90394	HUB, OIL BATH ASSY
27	4	8570	28L-26-R3 TR-90 TIRE
*	4	72404	TIRE, 28L - 26, BIAS, ATG
*	4	72405	TIRE, 28L R26, RAD, ATG

***MEANS NOT SHOWN**

FIGURE 10 OILER KIT

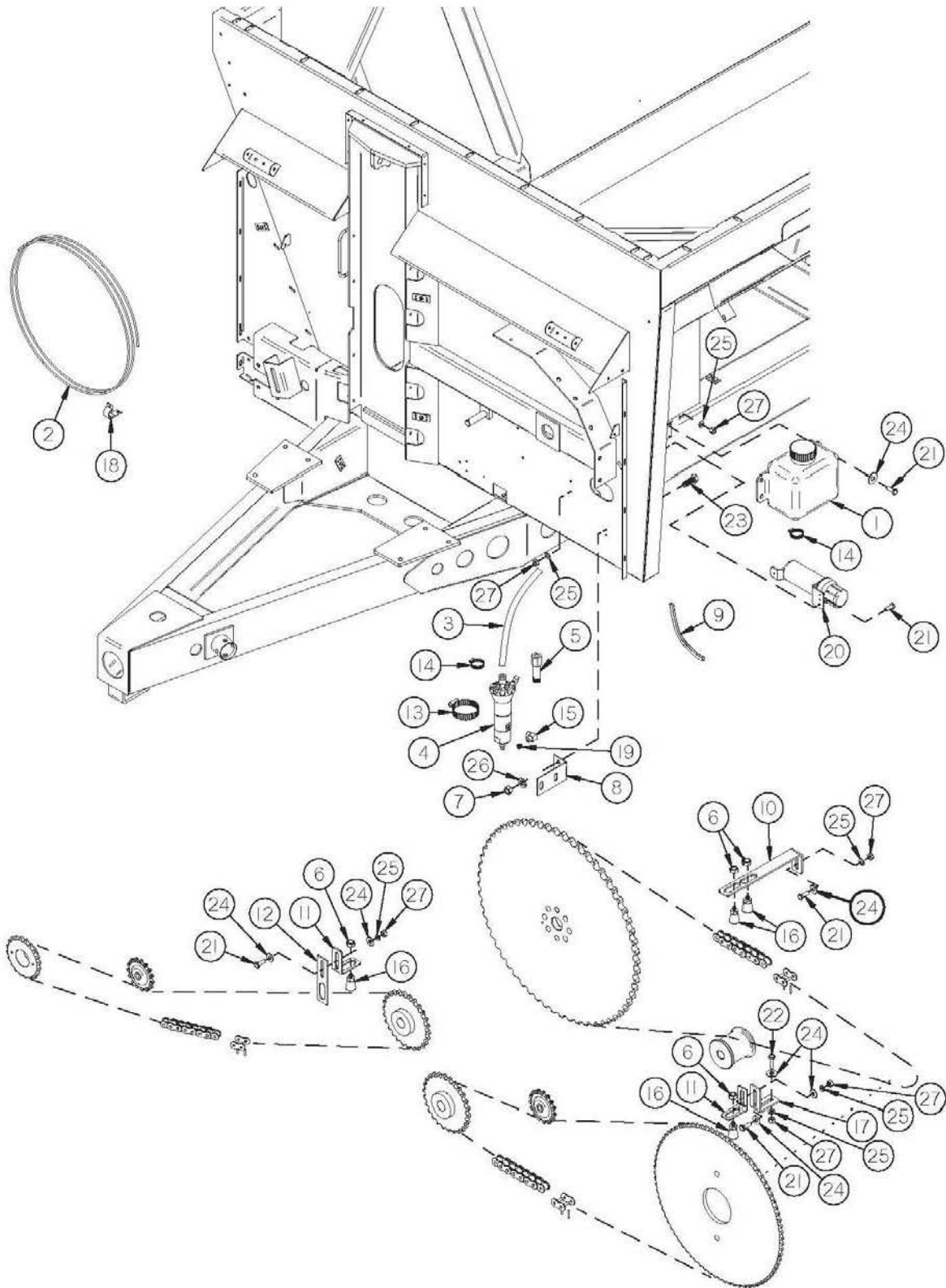

FIGURE 10 OILER KIT

<u>ITEM</u>	<u>QTY</u>	<u>PART#</u>	<u>DESCRIPTION</u>
1	1	HGV63	RESERVOIR
2	1	HGV71	OIL TUBE
3	1	HGV66	FILLER HOSE
4	1	HGV82	PUMP (COMPLETE)
5	4	HGV84	170-4515 MANIFOLD ASSEMBLY
6	4	YNHX16005	NUT HEX, 1/2
7	2	YNHX12005	NUT HEX, 3/8-16
8	1	HGV68	PUMP MOUNT BRACKET
9	1	HGV77	EDGING
10	1	TS322	EXTRA LONG BRUSH BRACKET
11	2	TS98	OILER BRUSH BRACKET SINGLE
12	1	HGV70	BRACKET MOUNT
13	1	HGV74	HOSE CLAMP, 2
14	2	HGV75	HOSE CLAMP, 1
15	1	HGV65	O-RING/JIC ELBOW
16	4	HGV67	BRUSH
17	1	TS321	OILER HANGER
18	2	HGV162	RUBBER WIRE HOLDER, 1/2
*	2	TS269	RUBBER WIRE HOLDER, 1/4
*	2	YSHW08005	SCREW HEX, WASHER, 1/4-20 X 3/8
19	1	TS198	ORIFICE .015 (4XHX7-S)
20	1	S522	MANUAL HOLDER
21	10	YBHH08100	BOLT HEX, 1/4 X 3/4 G5
22	1	YBHH08010	BOLT HEX, 1/4 X 1 G5
23	2	YBHH12135	BOLT HEX, 3/8 X 3/4 G5
24	10	YWFL08005	WASHER FLAT, 1/4
25	11	YWLO08005	WASHER LOCK, 1/4
26	2	YWLO12005	WASHER LOCK, 3/8
27	11	YNHX08005	NUT HEX, 1/4-20
*	1	HGV62	COMPLETE OILER KIT

***MEANS NOT SHOWN**

FIGURE 11 **FRONT GREASE LINES**

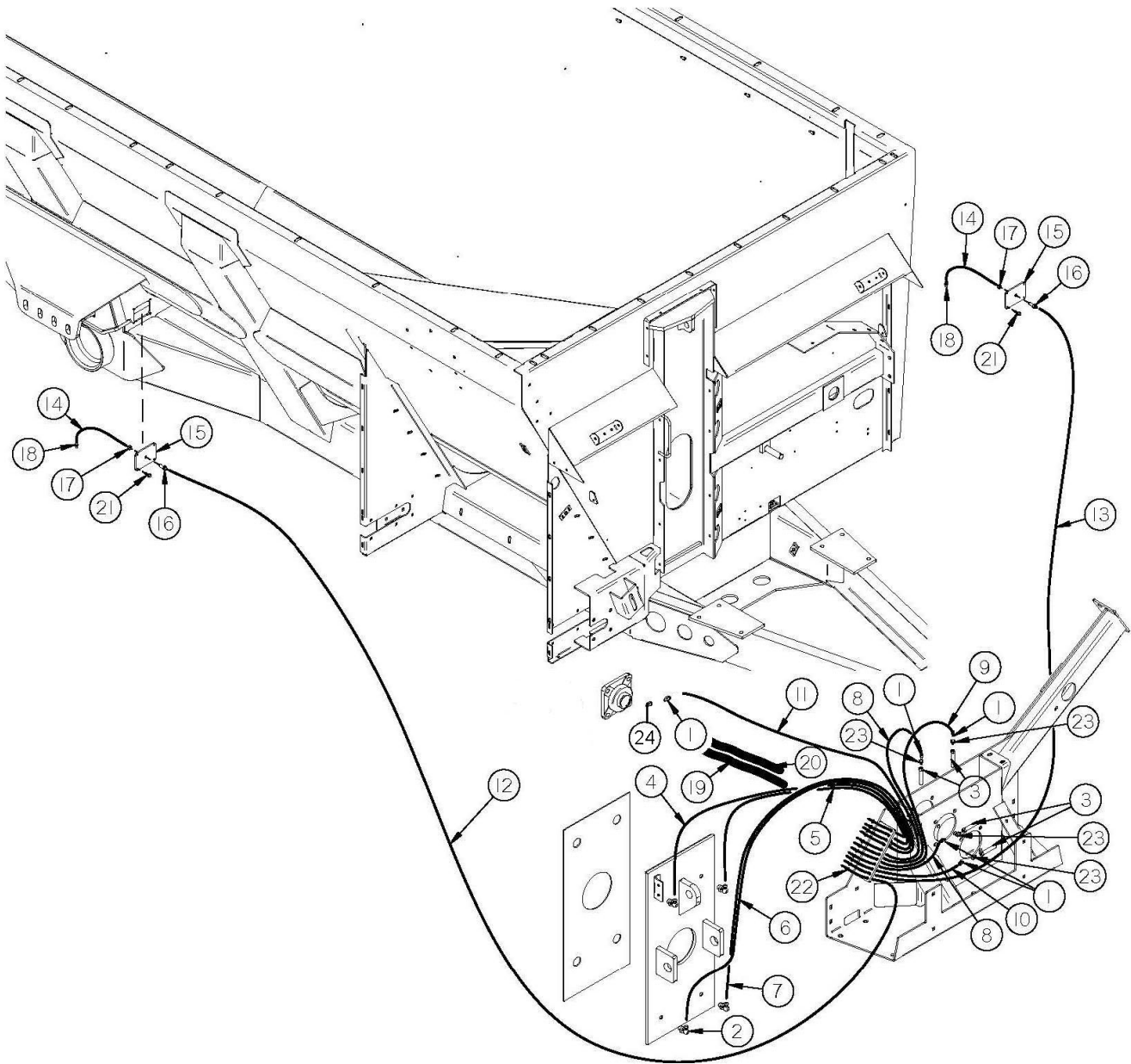

FIGURE 11

FRONT GREASE LINES

<u>ITEM</u>	<u>QTY</u>	<u>PART#</u>	<u>DESCRIPTION</u>
1	5	66078	COUPLING, 1/8 FEMALE PIPE & 1/8 FEMALE PIPE
2	4	GM30	1/8 90° GREASE LINE ADAPTER
3	4	66077	NIPPLE, 1/8 MALE PIPE X 2-1/2
4	1	TS265	GREASE LINE, 81
5	1	TS266	GREASE LINE, 82
6	1	TS267	GREASE LINE, 97
7	1	TS268	GREASE LINE, 101
8	2	TS270	GREASE LINE, 10.5
9	1	TS271	GREASE LINE, 16
10	1	TS272	GREASE LINE, 17.5
11	1	TS273	GREASE LINE, 47.75
12	1	APX3MS38	GREASE LINE, 200
13	1	APX3MS39	GREASE LINE, 230
14	2	APX3MS37	GREASE LINE, 12
15	2	APX43G14	ZERK ACCESS PANEL
16	2	1089	BULKHEAD UNION -4 JIC
17	2	1090	BULKHEAD LOCKNUT
18	2	53449	MALE CONNECTOR 1/8 NPT TO -4 JIC
19	1	TS246	SPLIT LOOM, 3/4 X 18
20	1	TS332	SPLIT LOOM, 3/4 X 14
*	2	HGV72	RUBBER WIRE HOLDER, 3/4
21	8	YBFB10001	BOLT FLANGE, SERRATED, 5/16-18 X 1 G5
22	11	YNJM04005	NUT JAM, 1/8 A
23	4	66079	HEX ADAPTER, 1/4 FEMALE & 1/8 FEMALE PIPE
24	1	TS323	FITTING STRAIGHT, 1/4-28, 1/8-27NPT

***MEANS NOT SHOWN**

FIGURE 12
LIGHTING

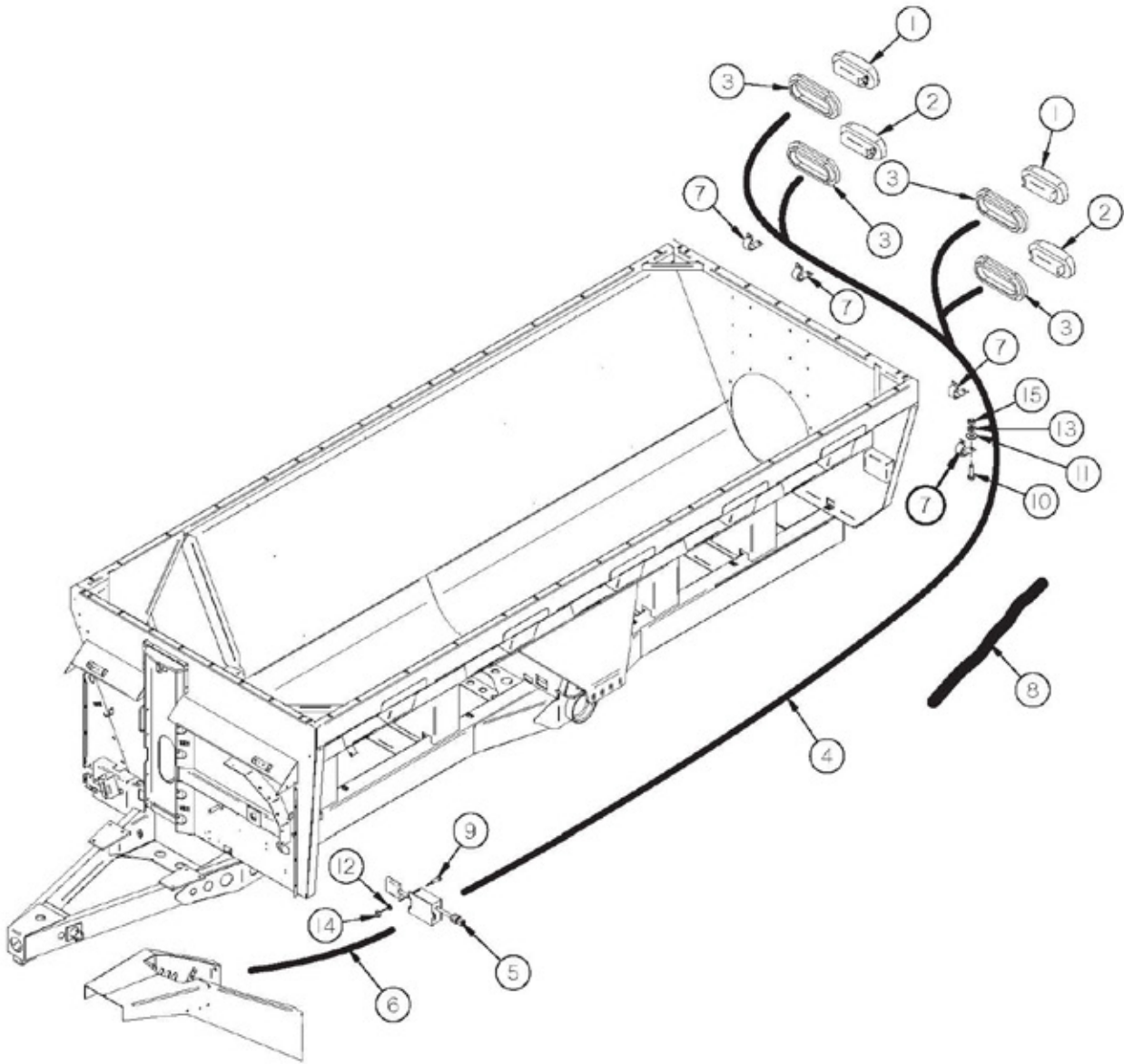

FIGURE 12 LIGHTING

<u>ITEM</u>	<u>QTY</u>	<u>PART#</u>	<u>DESCRIPTION</u>
1	2	S309	OVAL AMBER HAZARD TAIL LIGHT
2	2	S310	OVAL RED STOP/TURN TAIL LIGHT
3	4	S308	OVAL LIGHT GROMMET
4	1	56N155	HARNESS - TAIL LIGHT
5	1	69908	MODULE CONTROL BLINKER
6	1	TS317	HARNESS MODULE TO TRACTOR
7	4	HGV162	CUSHION WIRE CLAMP, 1/2
8	1	TS129	SPIRAL WRAP, 30
9	3	YSPP64010	SCREW MACHINE PAN, #10
10	4	YBHH10105	BOLT HEX, 5/16 X 3/4 G5
11	4	YWFL10005	WASHER FLAT, 5/16
12	3	YWLO08005	WASHER LOCK, 1/4
13	4	YWLO10005	WASHER LOCK, 5/16
14	3	YNHX64005	NUT HEX, MACHINE, #10 - 32
15	4	YNHX10005	NUT HEX, MACHINE, #10 - 32

FIGURE 13
AUGER

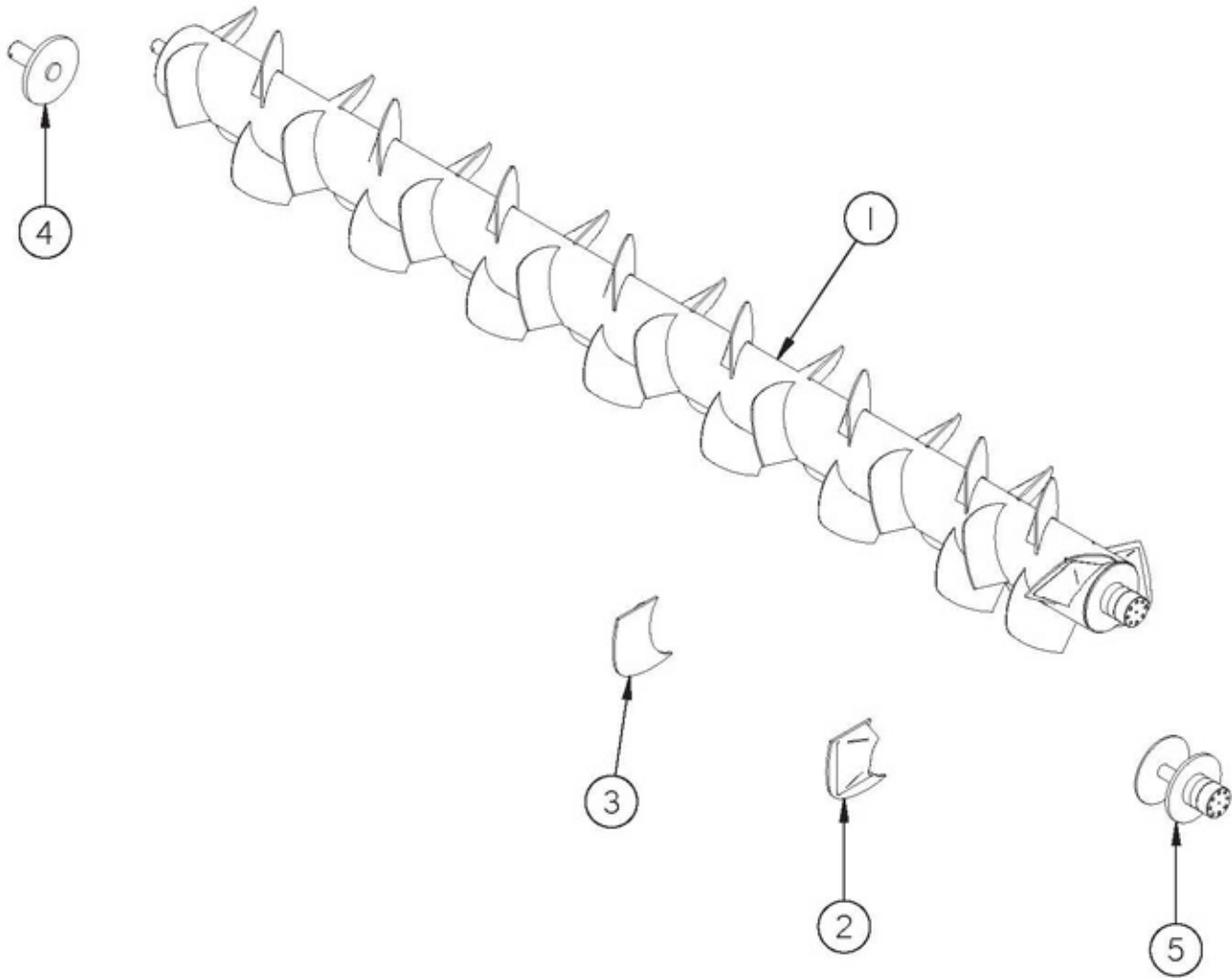

FIGURE 13 AUGER

<u>ITEM</u>	<u>QTY</u>	<u>PART#</u>	<u>DESCRIPTION</u>
1	1	APX4WE01	AUGER
2	2	TS275	FRONT AUGER PADDLE
3	40	TS276	BACK AUGER PADDLE
4	1	TS277	BACK AUGER
5	1	TS278	AUGER INPUT SHAFT

FIGURE 14 GEARBOX

<u>ITEM</u>	<u>QTY</u>	<u>PART#</u>	<u>DESCRIPTION</u>
1	1	TS240	GEARBOX
2	1	TS279	GEARBOX COVER
3	1	TS280	SECONDARY SHAFT
4	1	TS281	SPUR GEAR, (40T)
5	1	TS282	SPLINED INPUT SHAFT
6	1	TS283	SPUR GEAR, (20T)
7	4	TS284	BUSHING
8	4	TS285	BEARING
9	A/R	TS286	SHIM, 1/32 THICK
10	A/R	S36	SHIM, 3/16 THICK
*	A/R	S409	SHIM, 1/8 THICK
11	1	SD134	VENT PLUG
12	2	DWM159	PIPE PLUG, 3/4
13	2	56N174	3/8" X 2" SQUARE KEY, ROUND ENDS (HARDENED)
14	4	YBHH10075	BOLT HEX, 5/16 X 2 G8
15	4	YBHH12010	BOLT HEX, 3/8 X 1 G5
16	15	YBHH16065	BOLT HEX, 1/2 X 2 G5
17	1	YBHH16080	BOLT HEX, 1/2 X 2-1/2 G5
18	4	YWFL12005	WASHER FLAT, 3/8
19	4	YWLO12005	WASHER LOCK, 3/8
20	16	YWLO16005	WASHER LOCK, 1/2
21	4	YNHX12005	NUT HEX, 3/8
22	16	YNHX16005	NUT HEX, 1/2
23	1	YNJM16005	NUT HEX JAM, 1/2
24	4	YNL10005	NUT HEX, TOP LOCK, 5/16
*	1	APX3AS07	GEARBOX

***MEANS NOT SHOWN**

A/R MEANS AS REQUIRED

FIGURE 15 **AUGER FRONT/REAR HYDRAULIC CYLINDER**

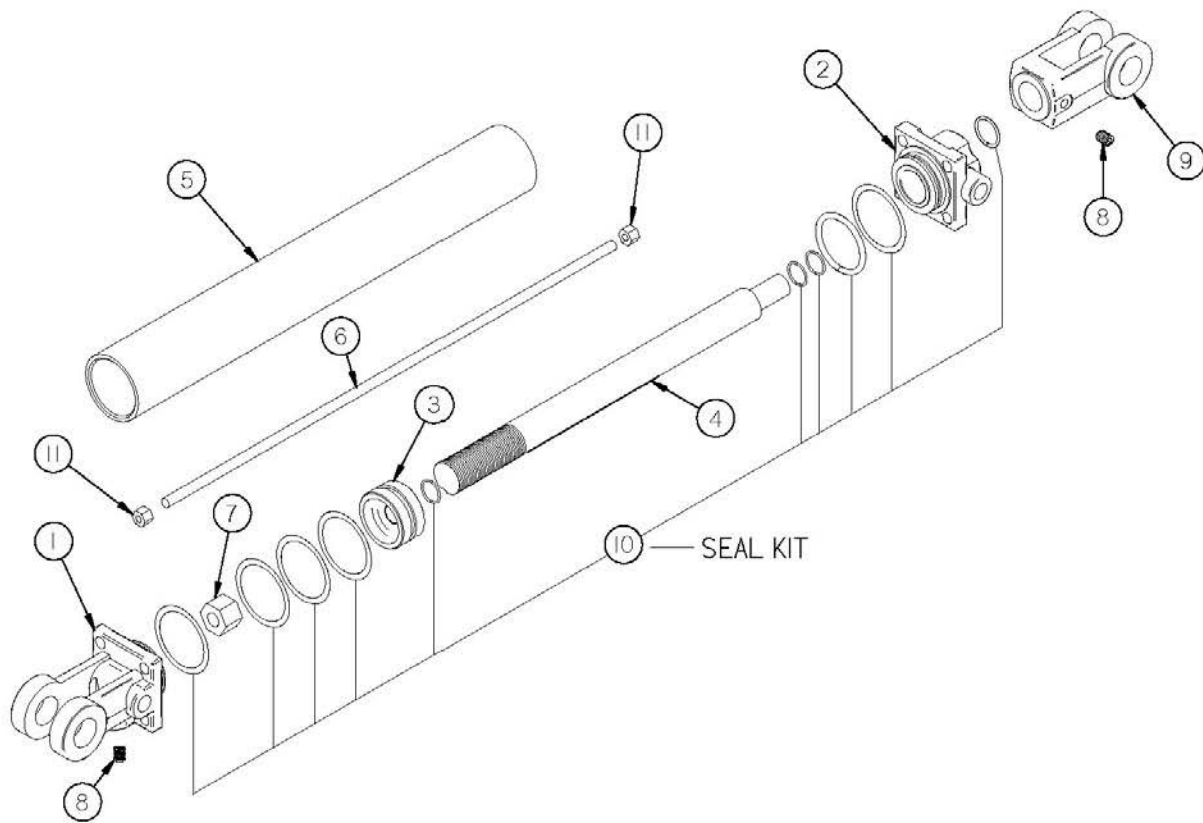

FIGURE 15
AUGER FRONT/REAR HYDRAULIC CYLINDER

<u>ITEM</u>	<u>QTY</u>	<u>PART# 3" BORE</u>	<u>PART# 3-1/4" BORE</u>	<u>DESCRIPTION</u>
1	1	TS160	TS176	BASE (3/4 - 16 SAE PORT)
2	1	TS158	TS174	HEAD (3/4 - 16 SAE PORT)
3	1	TS159	TS175	PISTON NUT
4	1	TS156	TS172	ROD
5	1	TS157	TS173	TUBE
6	4	TS153	TS171	TIE ROD
7	1	TS145	TS166	PISTON NUT
8	1	TS152	"	PLUG (3/4-16 SAE)
9	1	TS155	"	CLEVIS ASSEMBLY
10	1	TS163	TS177	SEAL KIT
11	8	TS144	TS165	TIE ROD NUT

FIGURE 16 **EXPELLER DOOR HYDRAULIC CYLINDER**

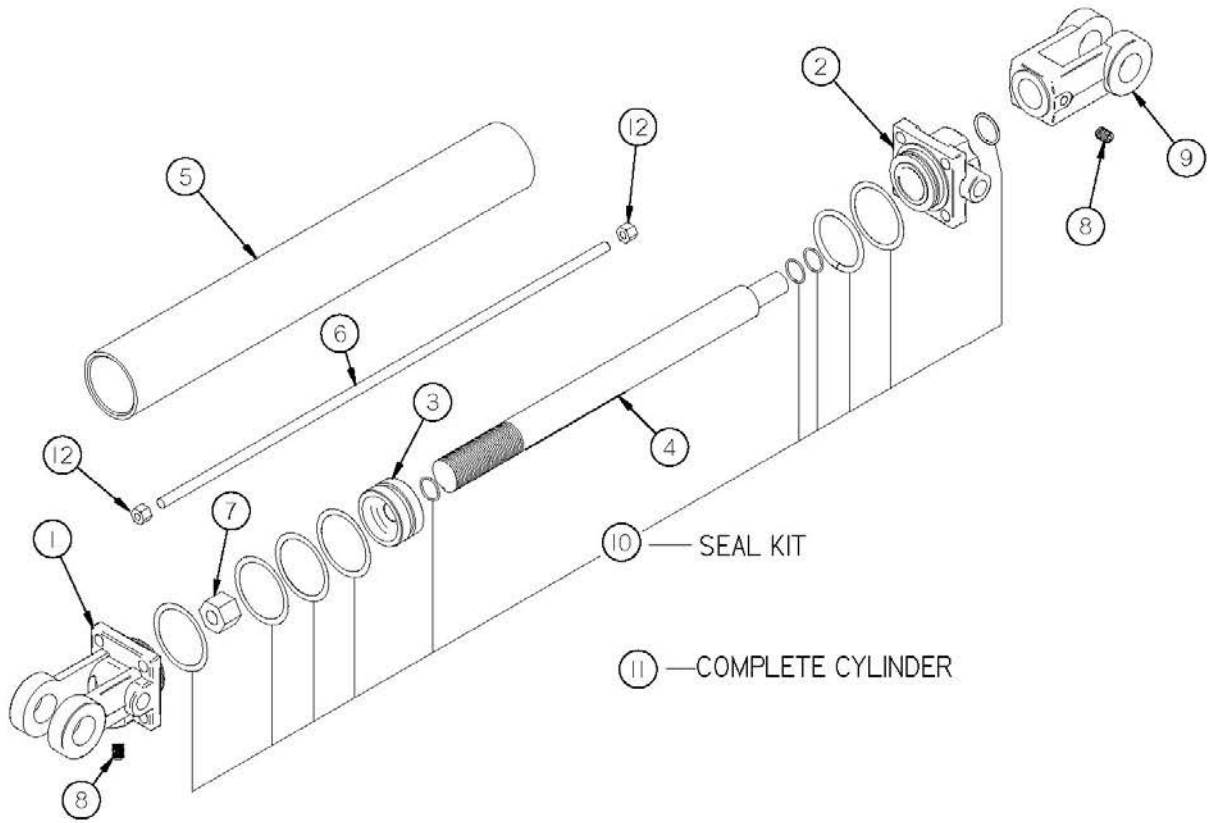

FIGURE 16

EXPELLER DOOR HYDRAULIC CYLINDER

<u>ITEM</u>	<u>QTY</u>	<u>PART#</u>	<u>DESCRIPTION</u>
1	1	23N142A	CLEVIS CAP
2	1	23N143	ROD CAP
*	1	56174	ROD CAP
3	1	23N144	PISTON
*	1	56180	PISTON
4	1	23N145A	ROD
5	1	23N146	CYLINDER TUBE
6	4	23N147	TIE ROD
7	1	23N148	PISTON NUT
8	2	23N149	PLUG
9	1	23N150A	ROD CLEVIS
10	1	23N151	SEAL KIT
*	1	56187	SEAL KIT
11	1	23N111A	HYD CYLINDER, 2 X 16
*	1	56015	HYD CYLINDER, 2 X 16
12	8	YNHX12005	NUT HEX, 3/8

***MEANS NOT SHOWN**

FIGURE 17
PTO (1000RPM 1-3/8)

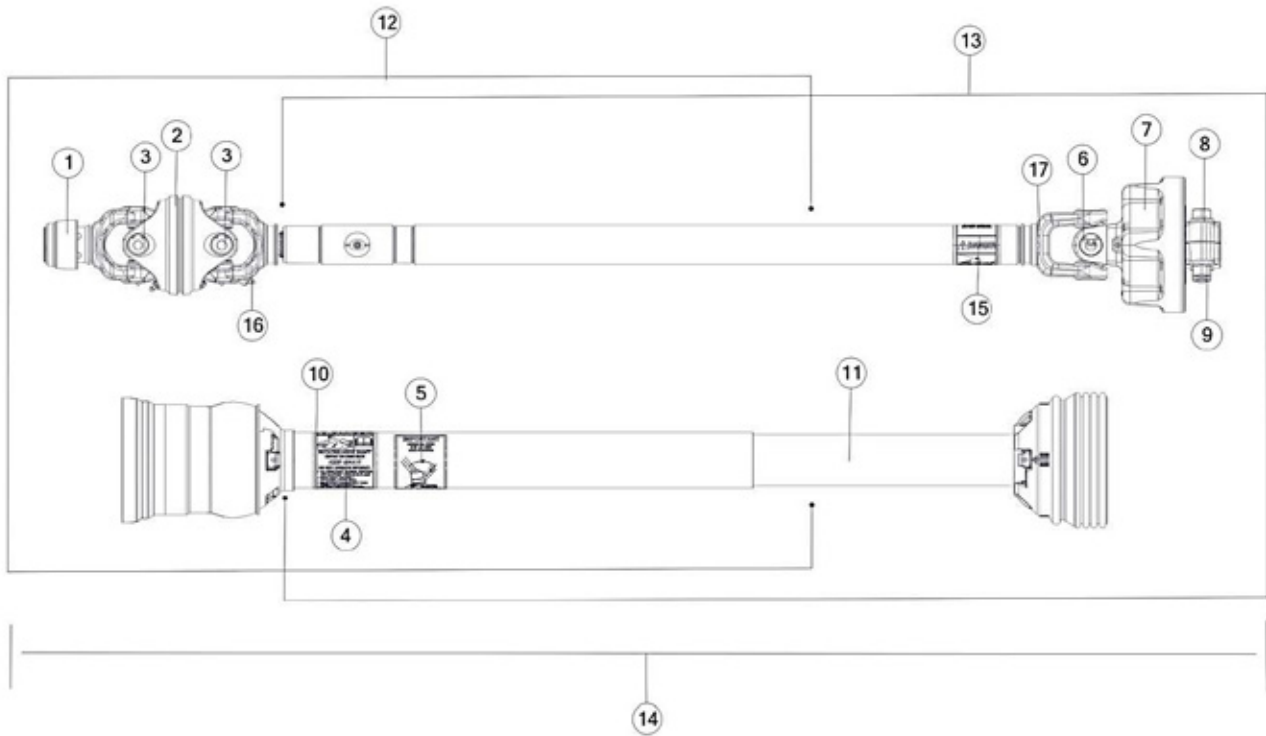

FIGURE 17
PTO (1000RPM 1-3/8)

<u>ITEM</u>	<u>QTY</u>	<u>PART#</u>	<u>DESCRIPTION</u>
1	1	63389	YOKE, 4 80 WWCV, AUTO-LOC
2	1	TS180	CENTER HOUSING
3	2	TS179	CROSS KIT
4	1	1494L	SAFETY SIGN
5	1	16SV286	SAFETY SIGN (C.V INSTRUCTIONAL DECAL)
6	1	16SV179	35R CROSS & BEARING KIT
7	1	70562	PTO, CLUTCH 35 AUTO, 15900 IN-LBF MIN.
8	1	YBFB20040	BOLT FLANGE, 5/8-11 X 3.00 G8
9	1	YNSF20005	NUT FLANGE, 5/8-11
10	1	TS288	OUTER GUARD
11	1	70570	SHIELD, PTO SHAFT INNER GUARD
12	1	TS292	JOINT & SHAFT HALF ASSM W/ GUARD
13	1	70576	PTO, JOINT & SHAFT HALF, GUARDED, 1000 RPM
14	1	70324	PTO, 1000 RPM, 19500 IN-LBF, AUTO
15	1	16SV388	SAFETY SIGN
16	1	63390	YOKE & SHAFT (1.31-20 SPLINE)
17	1	70569	PTO, YOKE, TUBE & SLIP SLEEVE, 1000 RPM
*	1	16SV274	SAFETY SLIDE LOCK REPAIR KIT
*	1	16SV383	GUARD REPAIR KIT
*	1	S402	ADMA SAFETY MANUAL

***MEANS NOT SHOWN**

FIGURE 18
PTO (1000RPM 1-3/4)

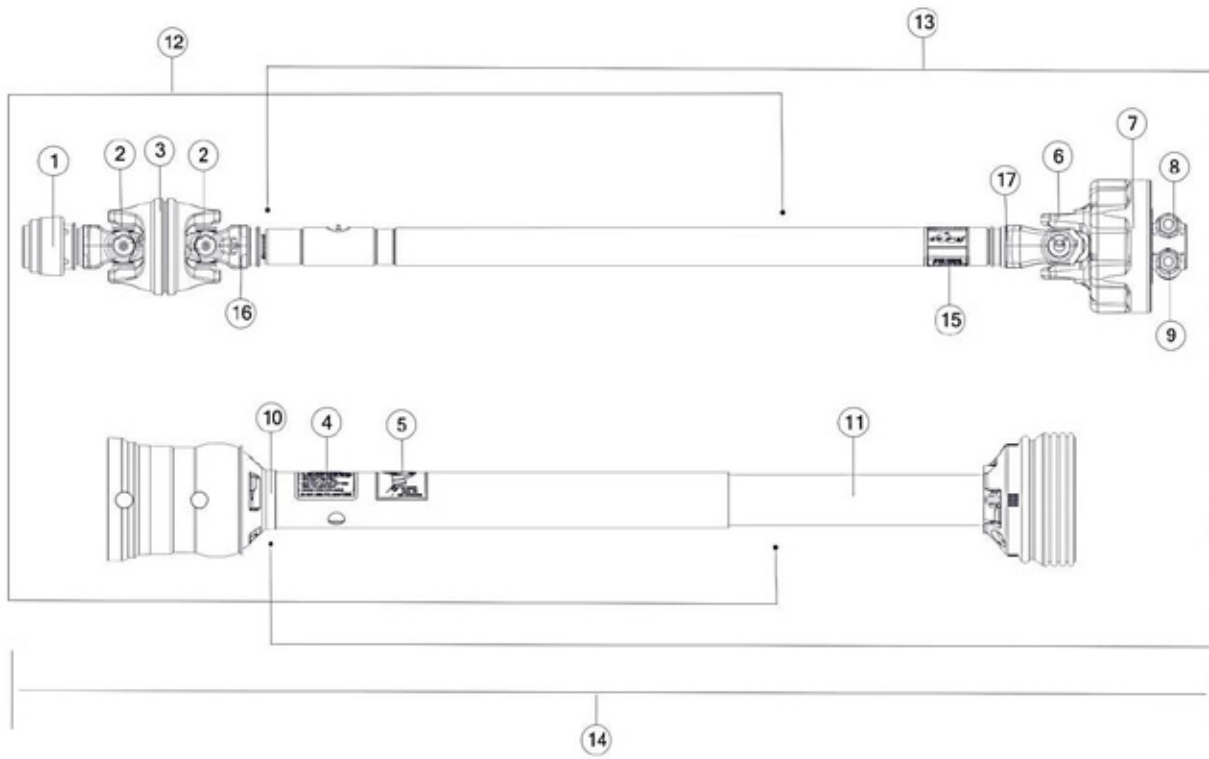

FIGURE 18
PTO (1000RPM 1-3/4)

<u>ITEM</u>	<u>QTY</u>	<u>PART#</u>	<u>DESCRIPTION</u>
1	1	TS193	AUTO LOK YOKE ASSEMBLY
2	2	TS179	CROSS KIT
3	1	TS180	CENTER HOUSING
4	1	70567	DECAL, SAFETY SIGN
5	1	16SV286	SAFETY SIGN (C.V INSTRUCTIONAL DECAL) 35R
6	1	16SV179	CROSS & BEARING KIT
7	1	70562	PTO, CLUTCH 35 AUTO, 15900 IN-LBF MIN.
8	1	YNSF20005	NUT FLANGE, 5/8-11
9	1	YBFB20040	BOLT FLANGE, 5/8-11 X 3.00 G8
10	1	TS288	OUTER GUARD
11	1	70570	SHIELD, PTO SHAFT INNER GUARD
12	1	TS296	JOINT & SHAFT HALF ASSM. W/GUARD
13	1	70576	PTO, JOINT & SHAFT HALF, GUARDED, 1000 RPM
14	1	70328	PTO, 1000 RPM, 19500 IN-LBF, AUTO
15	1	16SV388	SAFETY SIGN
16	1	63390	YOKE & SHAFT (1.31-20 SPLINE)
17	1	70569	PTO, YOKE, TUBE & SLIP SLEEVE, 1000 RPM
*	1	16SV383	GUARD REPAIR KIT
*	1	16SV275	SAFETY SLIDE LOCK REPAIR KIT
*	1	S402	ADMA SAFETY MANUAL

***MEANS NOT SHOWN**

FIGURE 19
SCALE

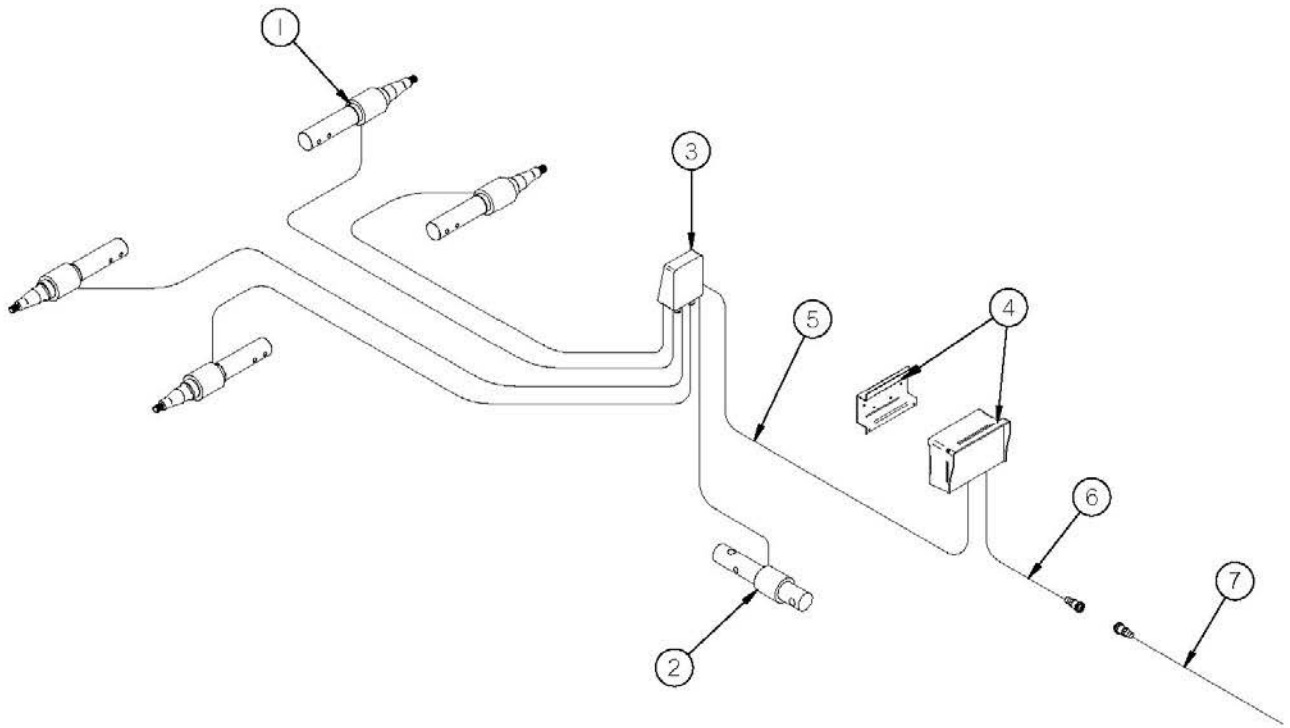

FIGURE 19 **SCALE**

<u>ITEM</u>	<u>QTY</u>	<u>PART#</u>	<u>DESCRIPTION</u>
1	4	TS335	SPINDLE LOAD CELL
2	1	TS336	HITCH LOAD CELL
3	1	TS83	JUNCTION BOX
4	1	GM408	SCALE HANGER BRACKET
*	1	TS337	SCALE DISPLAY W/GPS (OPTIONAL)
5	1	TS338	JUNCTION BOX CORD
6	1	TS385	POWER CORD
7	1	16SV269	TRACTOR POWER CORD

***MEANS NOT SHOWN**

FIGURE 20 **COVER COMPONENTS**

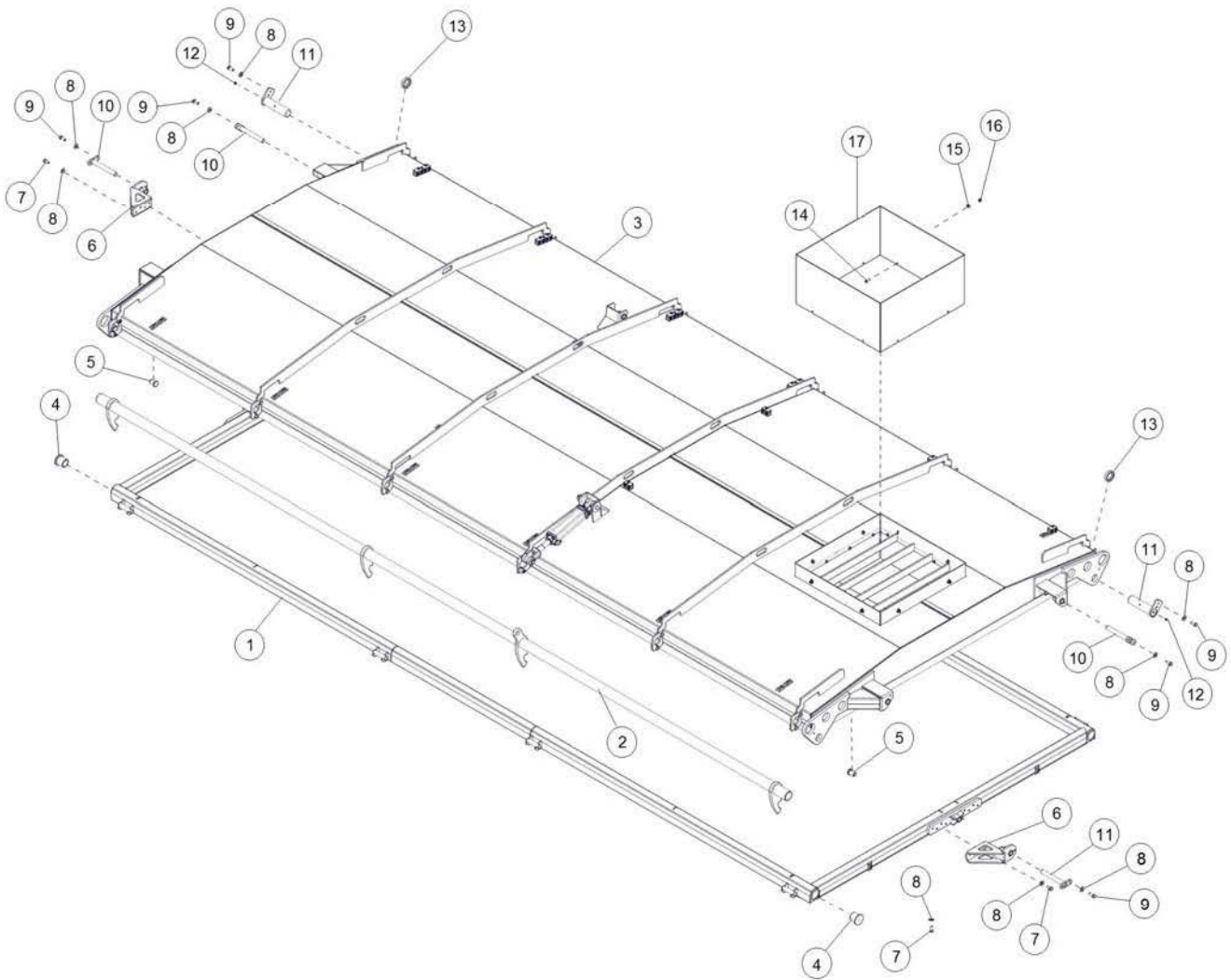

FIGURE 20

COVER COMPONENTS

<u>ITEM</u>	<u>QTY</u>	<u>PART#</u>	<u>DESCRIPTION</u>
1	1	52017	LID SUBFRAME WELDMENT
2	1	53076	CAM PIVOT WELDMENT
3	1	52025	LID WELDMENT
4	2	0229MS04	PIPE PLASTIC END PLUG
5	2	0229MS06	PIPE PLASTIC END PLUG 1.00
6	2	0229WE12	CYLINDER BASE MOUNT WELDMENT
7	56	YBHH16012	BOLT HEX, 1/2-13 X 1 G8
8	62	YWFL16005	WASHER FLAT, 1/2
9	4	YBHH16045	BOLT HEX, 1/2 X 1-1/4 G5
10	4	0229WE05	CYLINDER PIN HANDLE WELDMENT
11	2	0229WE03	HINGE PIN ASSY-RF
12	2	BFR28	1/8 NPT GREASE ZERK
13	2	0229TU05	HINGE SPACER
14	8	YBHH12010	BOLT HEX, 3/8-16 X 1 G5
15	8	YWFL12005	WASHER FLAT, 3/8
16	8	YNNY12005	NUT HEX, NYLON LOCKNUT, 3/8
17	1	56782	CHUTE EXTENSION

FIGURE 21 COVER HYDRAULICS

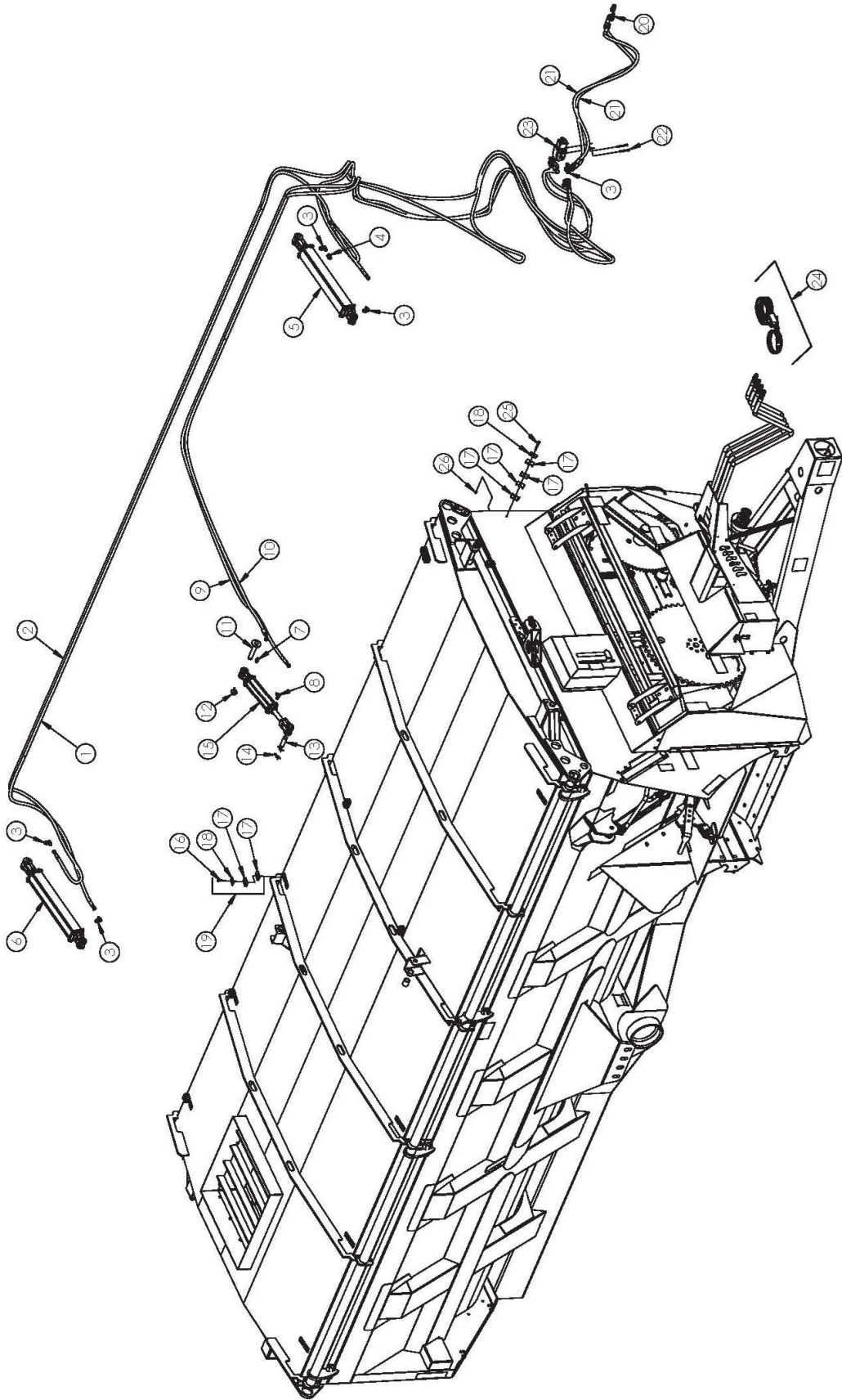

FIGURE 21

COVER HYDRAULICS

<u>ITEM</u>	<u>QTY</u>	<u>PART#</u>	<u>DESCRIPTION</u>
1	1	56070	HOSE, FCR TO RCB 351
2	1	56069	HOSE, VBR TO RCR 455
3	10	CHM206	06 90 DEG TO 3/4-16 ORB FITTING
4	1	1023	06-06 M/F ORIFICE, 0.047
5	1	1019	3.25 IN X 20 IN STROKE MASTER CYLINDER
*	1	8267	MASTER CYLINDER SEAL KIT
6	1	1020	STROKE SLAVE CYLINDER, 3 X 20
*	1	8266	SLAVE CYLINDER SEAL KIT
7	1	CHM202	3/8 MALE NPT TO -6 MALE JIC
8	1	CHM164	MALE ELBOW CTX 6-6 CTX
9	1	56067	HOSE, LOCK CYL ROD END 398"
10	1	56066	HOSE, LOCK CYL BASE END 387"
11	1	56N163	ENDGATE HINGE PIN
12	1	YPLY12010	LYNCH PIN, 3/8 X 1-3/4
13	1	T143	CYLINDER PIN
14	2	53371	CYLINDER PIN
15	1	BFR69A	HYD. CYLINDER, COMPLETE, 2 X 8
16	13	56568	CLAMP BOLT
17	15	CHM278	3/8 TWO LINE CLAMP BLOCK (SET OF 2)
*	1	56569	CLAMP BOLT, 5/16 X 1-3/4"
18	15	56563	COVER PLATE
19	13	CHM270	3/8 TWO HOSE CLAMP, COMPLETE
20	2	DWM205	QUICK COUPLING MALE
21	2	56068	HOSE, TRACTOR TO VALVE 58
22	2	YSHS10021	SCREW SOCKET HEAD CAP, 5/16-18 X 2-1/2
23	1	FR81	SOLENOID SELECTOR VALVE
24	1	56136	TOP SHOT LID COMPLETE CONTROL BOX
25	2	YBHH10097	BOLT HEX, 5/16 X 3 G5
26	3	YNNY10005	NUT HEX, NYLON LOCKNUT, 5/16-18

***MEANS NOT SHOWN**

FIGURE 22
COVER SEAL

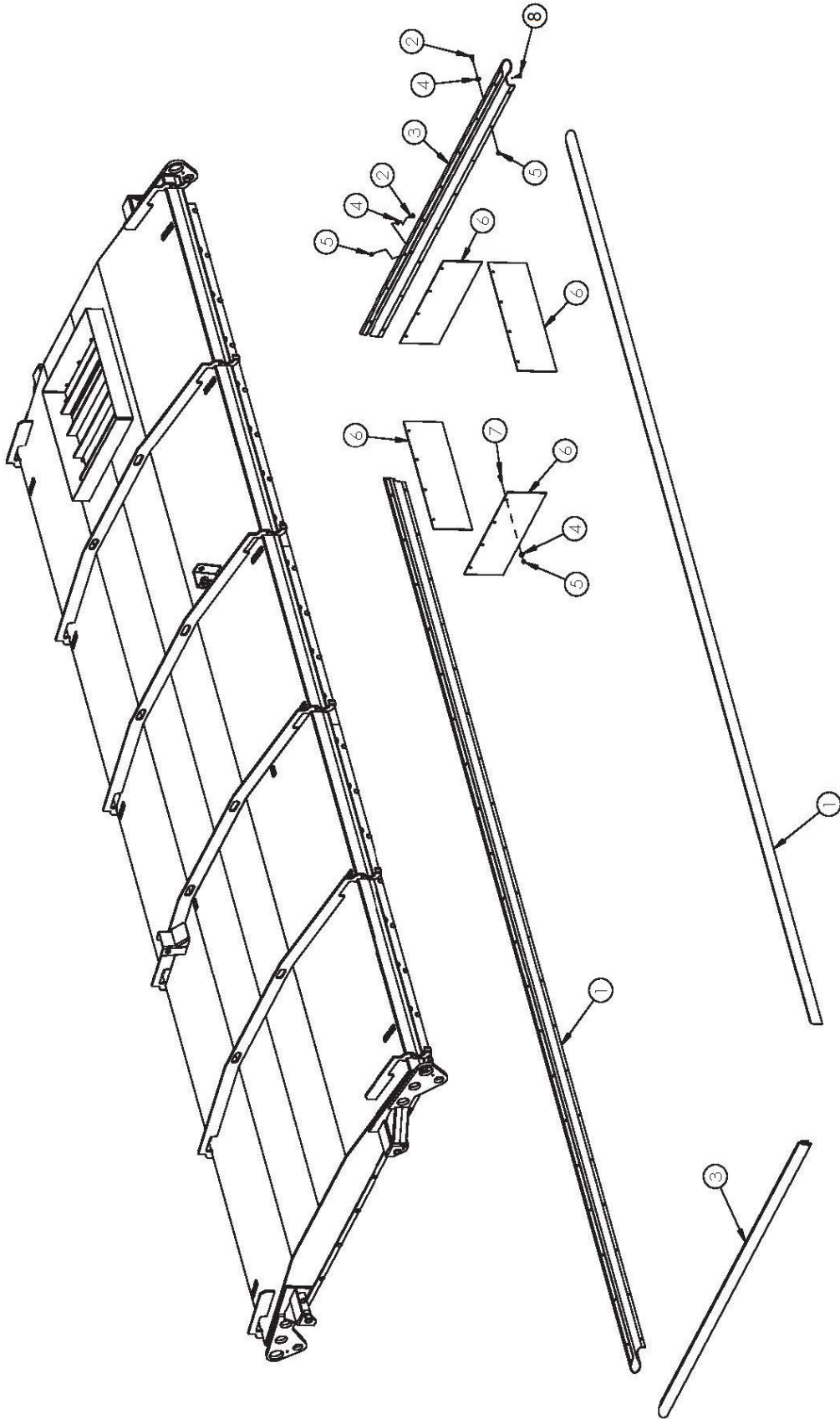

FIGURE 22 COVER SEAL

<u>ITEM</u>	<u>QTY</u>	<u>PART#</u>	<u>DESCRIPTION</u>
1	2	52033	SEAL BELT, LONG
2	56	YBCR12010	BOLT CARRIAGE, 3/8 X 1 G5
3	2	0229MS02	SEAL BELT, SHORT
4	128	YWFL12005	WASHER FLAT, 3/8 G5
5	128	YNNY12005	NUT HEX, NYLON LOCKNUT, 3/8
6	4	0229MS05	BELTING, CHUTE
7	16	YBHH12010	BOLT HEX, 3/8 X 1 G5
8	56	YBCR12020	BOLT CARRIAGE, 3/8 X 1-1/4 G5

FIGURE 23 **OPTIONAL BRAKES**

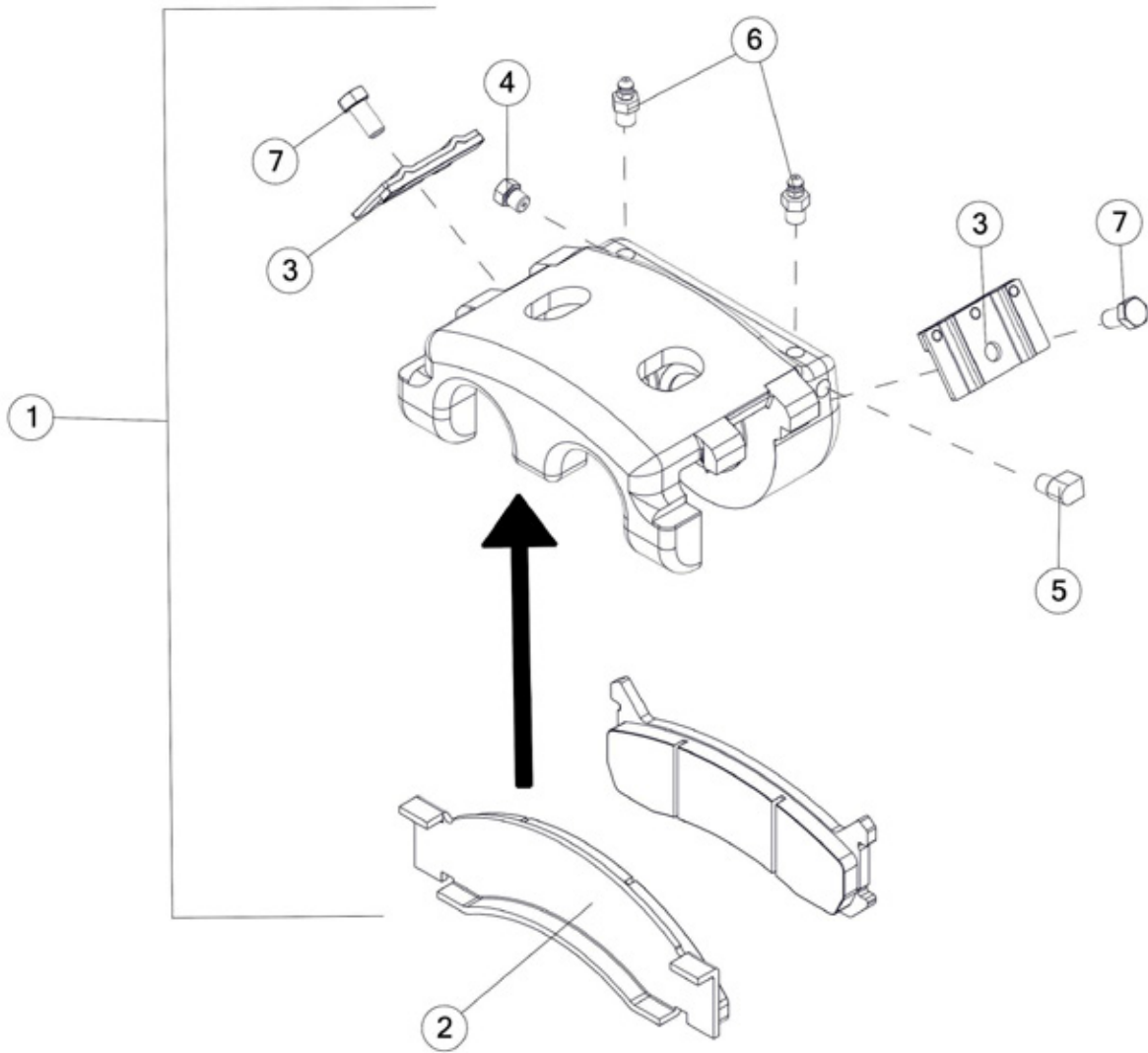

FIGURE 23 OPTIONAL BRAKES

<u>ITEM</u>	<u>QTY</u>	<u>PART#</u>	<u>DESCRIPTION</u>
1	1	56733	COMPLETE DUAL 2.50 PISTON CALIPER W/PADS & CLIPS
2	2	56961	BRAKE PAD SET
3	2	56963	CALIPER RETAINING CLIP
4	1	57178	BRASS 1/8 NPT PLUG
5	1	57180	ADAPTER PORT 90 DEG. 1/8NPT TO 3/16FIF
6	2	57179	BRASS BLEED PORT
7	2	YBHH12135	BOLT HEX, 3/8-16 X 3/4 G5

FIGURE 23 OPTIONAL BRAKES

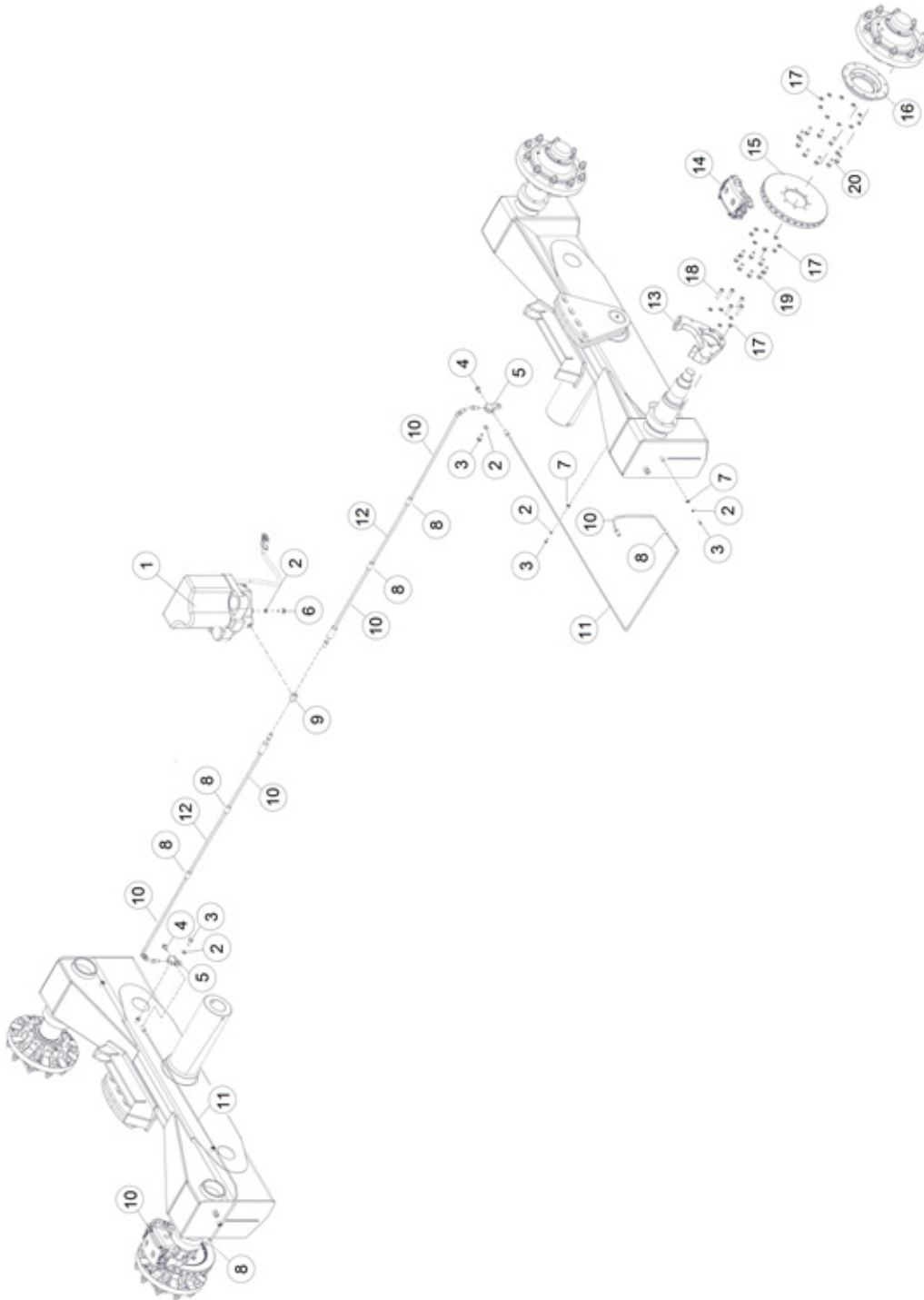

FIGURE 23

OPTIONAL BRAKES

<u>ITEM</u>	<u>QTY</u>	<u>PART#</u>	<u>DESCRIPTION</u>
1	1	FBC41	PUMP/MASTER CYLINDER
2	14	YWFL08005	WASHER FLAT, 1/4
3	10	YBHH08100	BOLT HEX, 1/4-20 X 3/4 G5
4	2	57176	BRAKE LINE PLUG, 3/16
5	2	RGB26	BRAKE LINE TEE
6	4	YBHH08010	BOLT HEX, 1/4-20 X 1 G5
7	6	FBC64	BRAKE LINE CLIP
8	2	57176	BRAKE LINE PLUG, 3/8-24
9	1	FBC45	TEE
10	6	FBC46	HYDRAULIC BRAKE HOSE
11	2	57343	STEEL BRAKE LINE, 3/16 X 38
12	2	57342	STEEL BRAKE LINE, 3/16 X 12
13	2	57000	CALIPER BRACKET
14	2	56733	DUAL 2.50 PISTON CALIPER
15	2	56734	ROTOR, 15
16	2	56953	ROTOR SPACER
17	46	YWLO16005	WASHER LOCK, 1/2
18	10	YSHS16015	BOLT SOCKET, 1/2-13X2 G8
19	16	YBHH16045	BOLT HEX, 1/2-13 X 1-1/4 X 3/4THRD G5
20	20	YBHH16107	BOLT HEX, 1/2-20 X 1-1/2 G5

FIGURE 23 OPTIONAL BRAKES



FIGURE 23
OPTIONAL BRAKES

<u>ITEM</u>	<u>QTY</u>	<u>PART#</u>	<u>DESCRIPTION</u>
1	1	FBC38	BRAKE CONTROL
2	1	57319	ELECTRIC-HYDRAULIC BRAKE HARNESS
3	2	YBHH08100	BOLT HEX, 1/4-20 X 3/4 G5
4	1	FBC39	BRAKE CONTROL MODULE
5	4	YWFL08005	WASHER FLAT, 1/4
6	2	YNHX08005	NUT HEX, 1/4-20

FIGURE 24 **DISCHARGE DEFLECTOR HYDRAULIC**

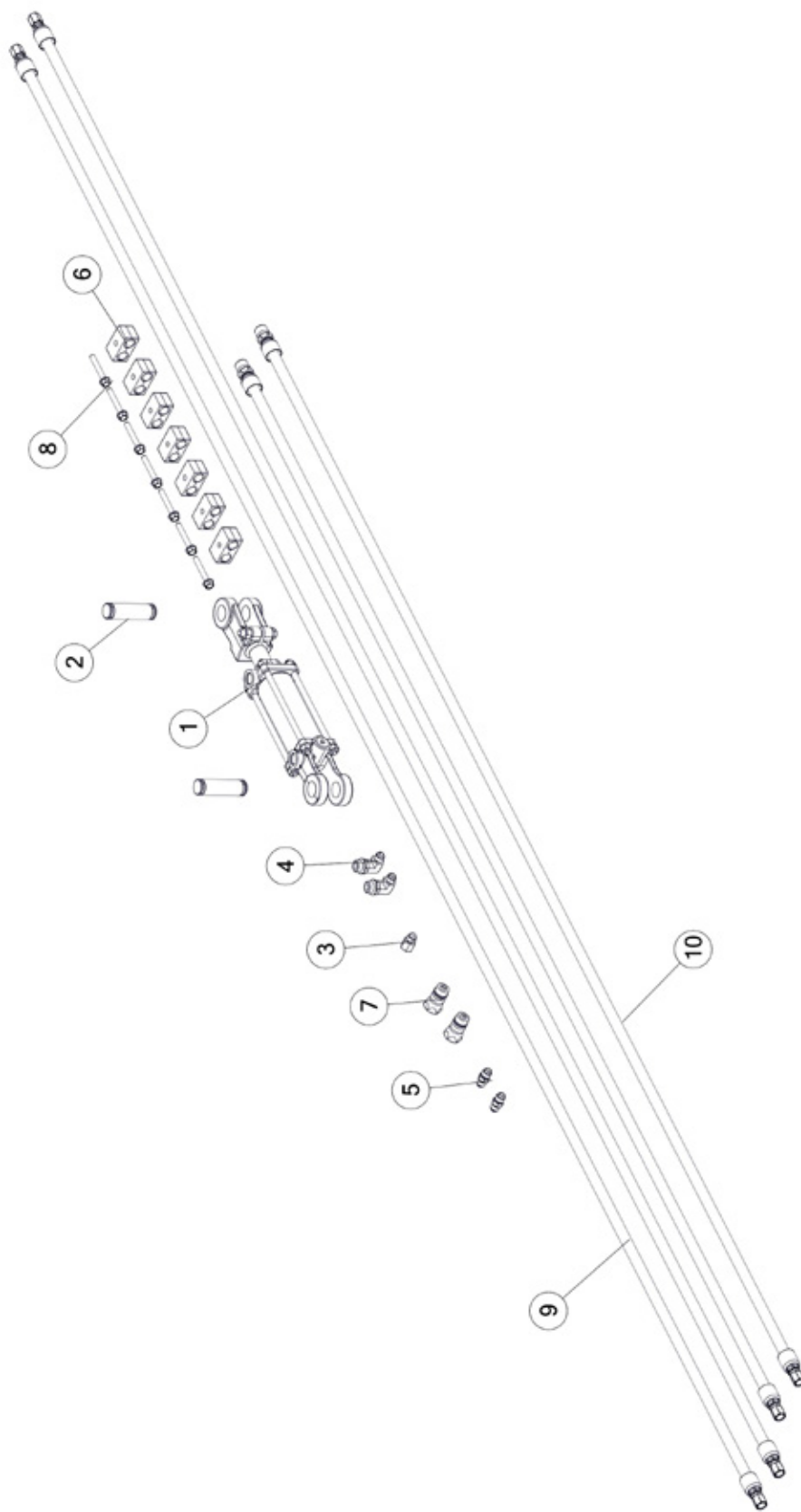

FIGURE 24
DISCHARGE DEFLECTOR HYDRAULIC

<u>ITEM</u>	<u>QTY</u>	<u>PART#</u>	<u>DESCRIPTION</u>
1	1	70797	CYLINDER, HYDRAULIC, 10.2 X 14.2
*	1	72161	SEAL KIT
2	2	72160	ASSEM, 2 CYL TIE ROD
3	1	58142	IN-LINE CONNECTOR, ORIFICE, 6-XHX7-S .031
4	2	CHM206	06 90 DEG TO 3/4-16 ORB FITTING
5	2	CHM258	FITTING ST, 6 JIC, 6 JIC
6	7	CHM278	3/8 TWO LINE CLAMP BLOCK
7	2	DWM205	VMI - MALE QUICK COUPLER S71-4P SAFEWAY HYD TIP
8	7	YBFB10225	BOLT FLG, 5/16 X 2-1/4 G5
9	2	85446	HYDRAULIC HOSE, 6, 127 IN
10	2	85664	HYDRAULIC HOSE, 6, 94 IN

***MEANS NOT SHOWN**

FIGURE 25
ELECTRIC VALVE FOR DISCHARGE DEFLECTOR HYD.CYL.

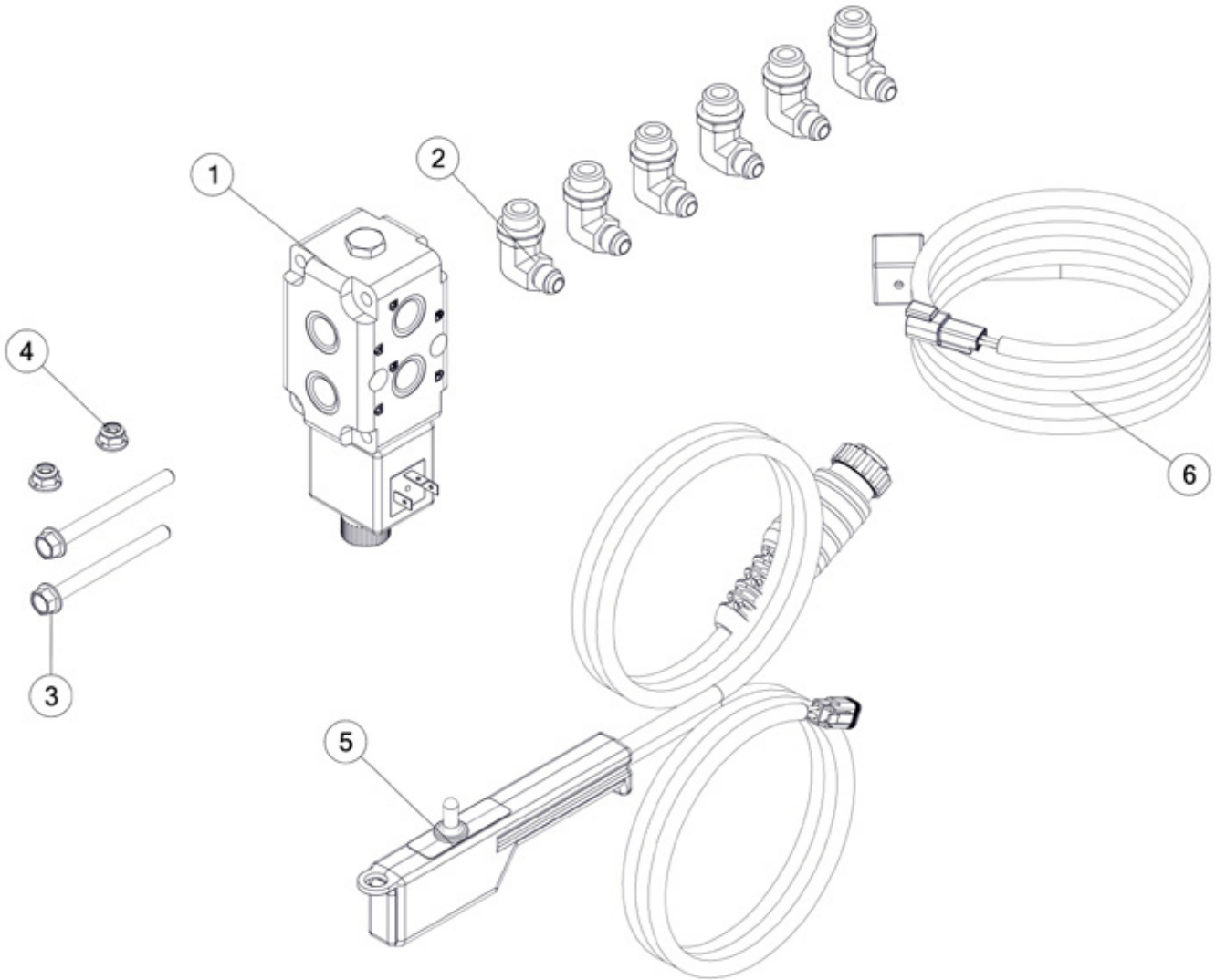

FIGURE 25

ELECTRIC VALVE FOR DISCHARGE DEFLECTOR HYD.CYL.

<u>ITEM</u>	<u>QTY</u>	<u>PART#</u>	<u>DESCRIPTION</u>
1	1	FR81	SOLENOID SELECTOR VALVE
2	6	CHM206	06 90 DEG TO 3/4-16 ORB FITTING
3	2	YBFB10350	BOLT FLANGE, 5/16 X 3-1/2 G8
4	2	YNFG10005	NUT FLANGE, 5/16 GF
5	1	85397	HAND CONTROLLER, (ON)-OFF
6	1	56138	10' DIN TO 2 PIN FEMALE DEUTSCH CORD

CHANGE NOTES

H&S MFG. CO.

products approved

for the

FEMA

SEAL OF QUALITY



Manufactured by:

H&S MANUFACTURING CO., INC.

2608 S. HUME AVE. MARSHFIELD, WI 54449

(715) 387-3414 | hsmfgco.com

