

# **H&S PARTS BOOK**

## **BIG DOG 26'**



Revision #00  
Starting Ser. #611100

Part #76906  
HSMFG1216

**P.O. BOX 768, MARSHFIELD, WI 54449  
(715) 387-3414 FAX (715) 384-5463  
[www.hsmfgco.com](http://www.hsmfgco.com)**

# CONTENTS

Instructions for Ordering Parts - About Improvements .....	1
Figure 1 - Body Panels.....	2-3
Figure 2 - Front Window & Components .....	4-5
Figure 3 - Front Panels & Components .....	6-7
Figure 4 - Floor & Components.....	8-9
Figure 5 - Front Idler Shaft Assembly.....	10-11
Figure 6 - Rear Idler Shaft Assembly .....	12-13
Figure 7 - Drive Sprocket Assembly (Right Side) .....	14-15
Figure 8 - Drive Sprocket Assembly (Left Side).....	16-17
Figure 9 - Hydraulics .....	18-19
Figure 10 - Gate Delay .....	20 -21
Figure 11 - Air Connection .....	22 -23
Figure 12 - Rear Transport Lighting.....	24-25
Figure 13 - Transport Lighting.....	26-27
Figure 14 - Optional Barn Doors.....	28-29
Figure 15 - Grain Kit.....	30-31
Figure 16 - Flow Control Kit .....	32-33
Figure 17 - Air Valve For Gate Delay .....	34-35
Parts Notes .....	36

## **INSTRUCTIONS FOR ORDERING PARTS**

All service parts should be ordered through your authorized H&S dealer. They will be able to give you faster service if you will provide them with the following

1. Model & Serial number is located on the left, rear main frame of your unit.
2. All reference to left or right apply to the machine as viewed from the rear.
3. Parts should not be ordered from illustration only. Please order by complete part number.
4. If your dealer has to order parts - give shipping instructions:  
VIA truck - large pieces (please specify local truck lines)  
VIA United Parcel Service (include full address)

<b>H&amp;S MFG. CO. INC.</b>	
<b>MARSHFIELD, WIS.</b>	
MOD. NO.	<input type="text"/>
SER. NO.	<input type="text"/>
DESCR.	<input type="text"/>

PLEASE RECORD NUMBERS FOR YOUR UNIT FOR QUICK REFERENCE

### **ABOUT IMPROVEMENTS**

H&S IS CONTINUALLY STRIVING TO IMPROVE IT'S PRODUCTS

We must therefore, reserve the right to make improvements or changes whenever it becomes practical to do so without incurring any obligation to make changes or additions to the equipment previously sold.

# FIGURE 1 BODY PANELS

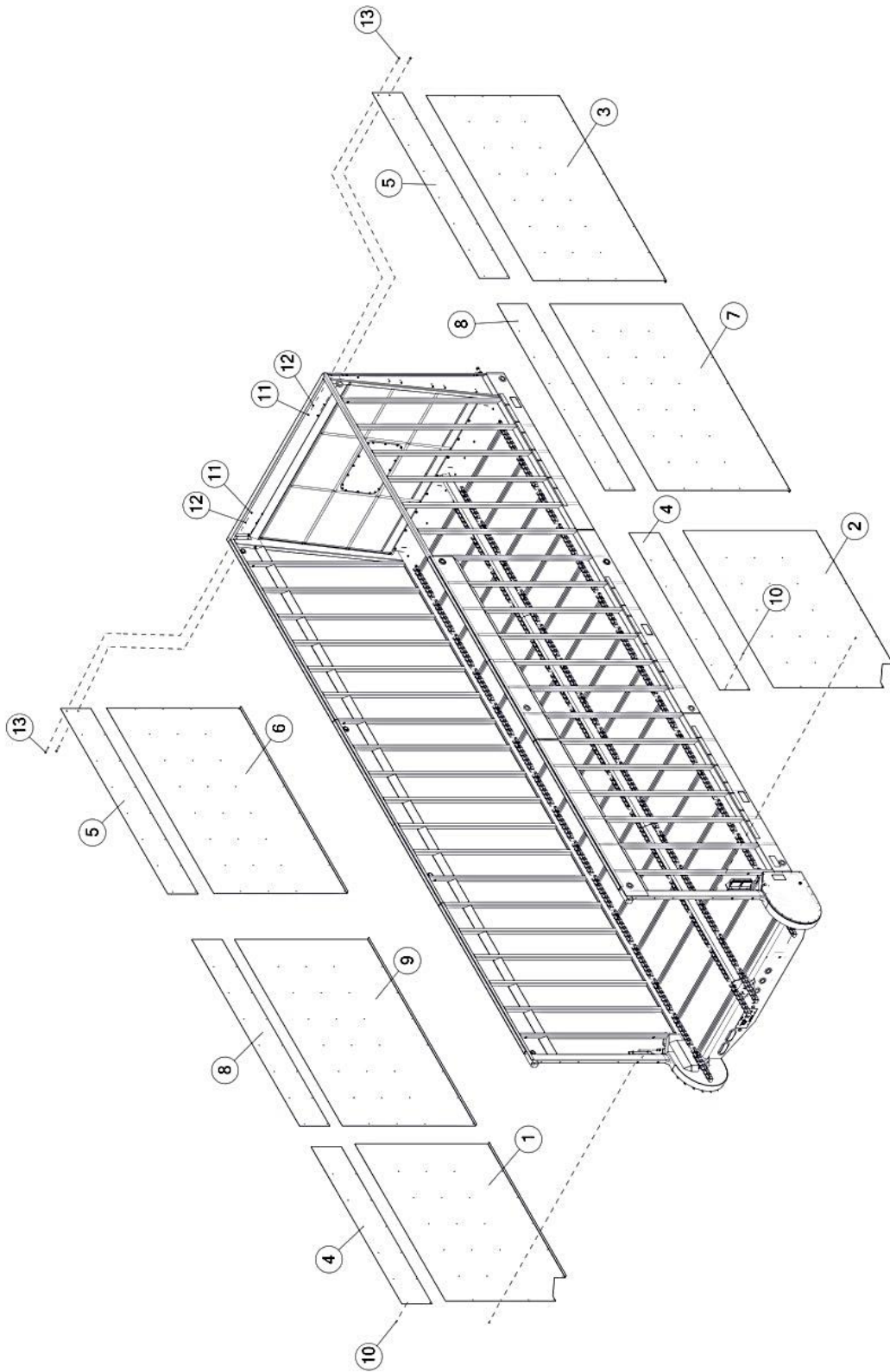

# FIGURE 1

## BODY PANELS

<u>ITEM</u>	<u>QTY</u>	<u>PART #</u>	<u>DESCRIPTION</u>
1	1	BBS25	SIDE BACK LEFT
2	11	BBS26	SIDE BACK RIGHT
3	2	BBS27	SIDE FRONT RIGHT
4	2	BBS70	SIDE EXTENSION REAR
5	1	BBS71	SIDE EXTENSION FRONT
6	1	BBST16G05	SIDE FRONT LEFT
7	1	BBST16G07	SIDE A
8	2	BBST16G11	SIDE EXTENSION CENTER
9	1	BBST16G15	SIDE B
10	212	1044	1/4" DIA, X .625" GRIP, SS, HUCK RIVET
11	4	YNHX12005	NUT, HEX, 3/8-16, A, ZC
12	4	YWLO12005	WASHER, LOCK, 3/8
13	4	YBHH12120	BOLT, HEX, 3/8-16 X 3, G5, ZC

# FIGURE 2

## FRONT WINDOW & COMPONENTS

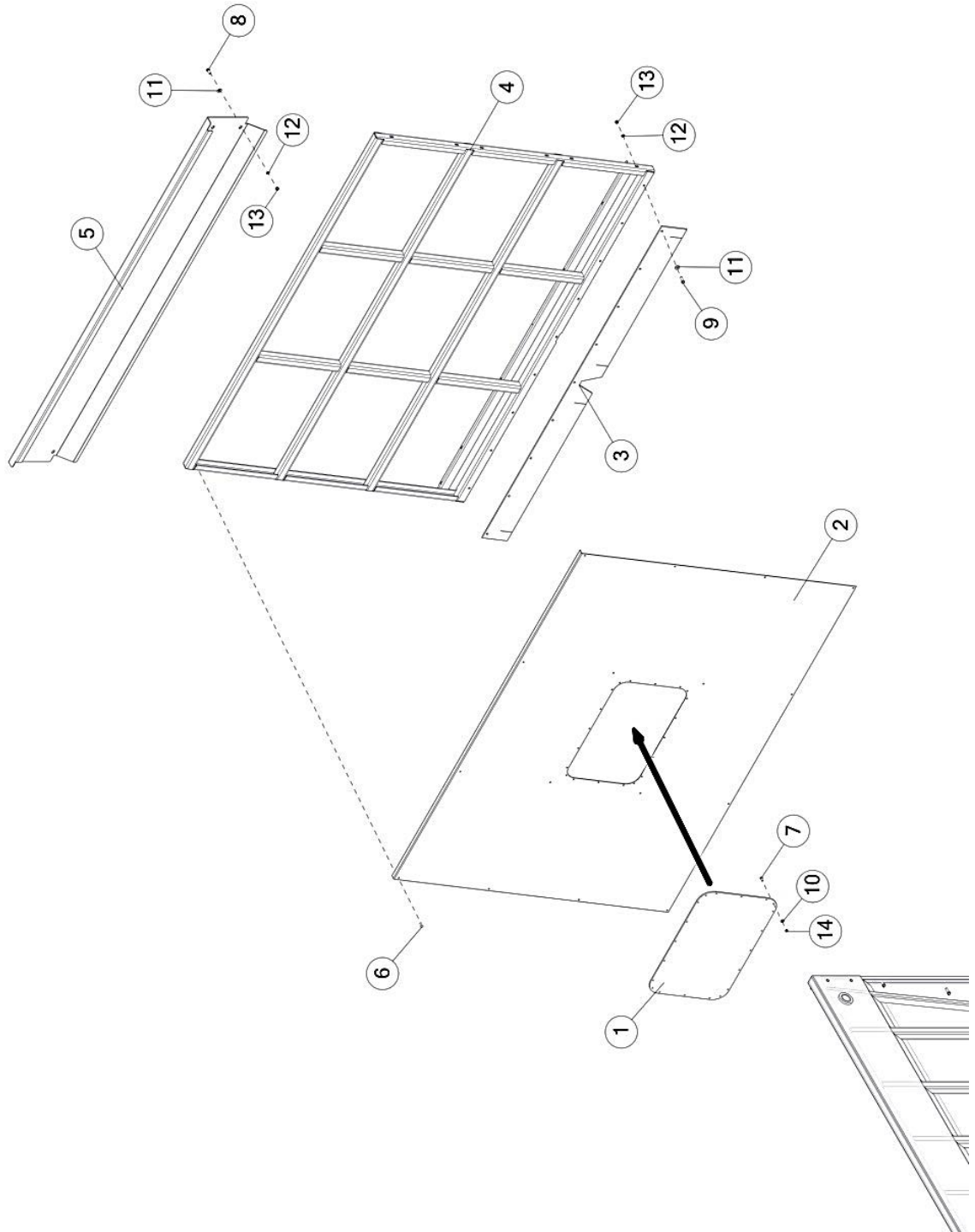

## FIGURE 2

### FRONT WINDOW & COMPONENTS

<u>ITEM</u>	<u>QTY</u>	<u>PART #</u>	<u>DESCRIPTION</u>
1	1	55839	WINDOW WITH HOLES
2	1	55840	FRONT PANEL
3	1	BBS48	FRONT SEAL RUBBER
4	1	BBS46	SLANT PANEL FRAME
5	1	023010G01	FRONT PANEL UPPER
6	12	1043	1/4" DIA, X .325" GRIP, SS, HUCK RIVET
7	20	YBHH08100	BOLT, HEX, 1/4-20 X 3/4, G5, ZC
8	4	YBHH12010	BOLT, HEX, 3/8-16 X 1, G5, ZC
9	9	YBHH12035	BOLT, HEX, 3/8-16 X 1-1/4, G5, ZC
10	20	YWFL08005	WASHER, FLAT, 1/4 USS
11	4	YWFL12005	WASHER, FLAT, 3/8 USS
12	13	YWLO12005	WASHER, LOCK, 3/8
13	13	YNHX12005	HEX NUT, 3/8"-16, GR. 2
14	20	YNNY08005	HEX NUT, NYLON LOCKNUT, 1/4-20

# FIGURE 3

## FRONT PANELS & COMPONENTS

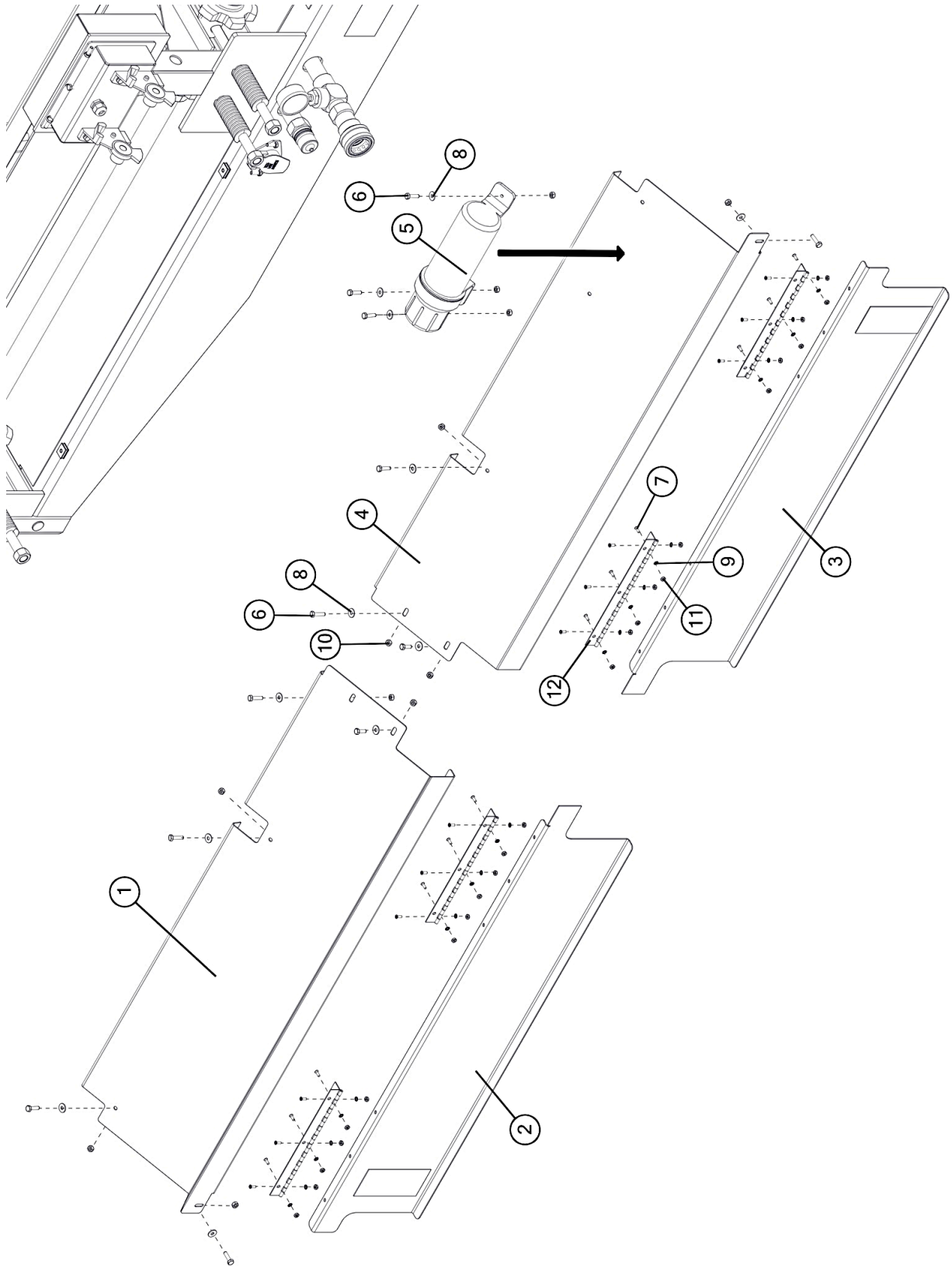



## FIGURE 3

### FRONT PANELS & COMPONENTS

<u>ITEM</u>	<u>QTY</u>	<u>PART #</u>	<u>DESCRIPTION</u>
1	1	BBS72	FRONT SHIELD
2	1	BBS73	FRONT SHIELD BOTTOM
3	1	BBST14G20	FRONT SHIELD BOTTOM LEFT
4	1	BBST14G28	FRONT SHIELD SLANT LEFT
5	1	S522	MANUAL HOLDER
6	12	YBHH08010	BOLT, HEX, 1/4-20 X 1, G5, ZC
7	24	YSFM62005	FLAT HEAD CAP SCREW, CROSS #8-32 X 1/2
8	12	YWFL08005	WASHER, FLAT, 1/4 USS
9	24	YWSI62005	#8 ZINC EXT LOCK WASHER
10	12	YNHX08005	NUT, HEX, 1/4-20, NA, A, ZC
11	21	YNHX62005	NUT, HEX, MACHINE, #8-32, NA, ZC
12	4	BBSTMS15	SS CONTINUOUS HINGE FLAT

**FIGURE 4**  
**FLOOR & COMPONENTS**

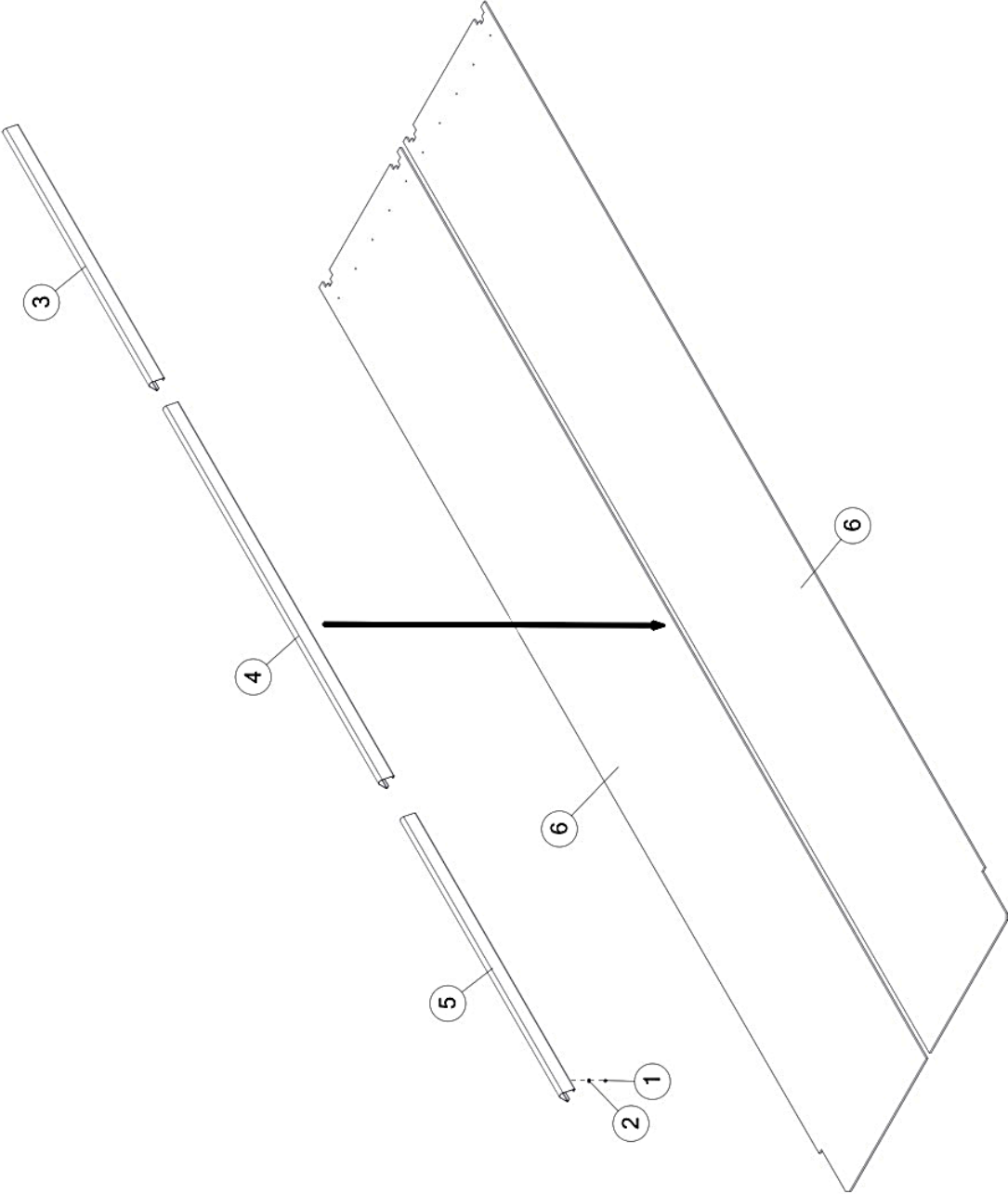
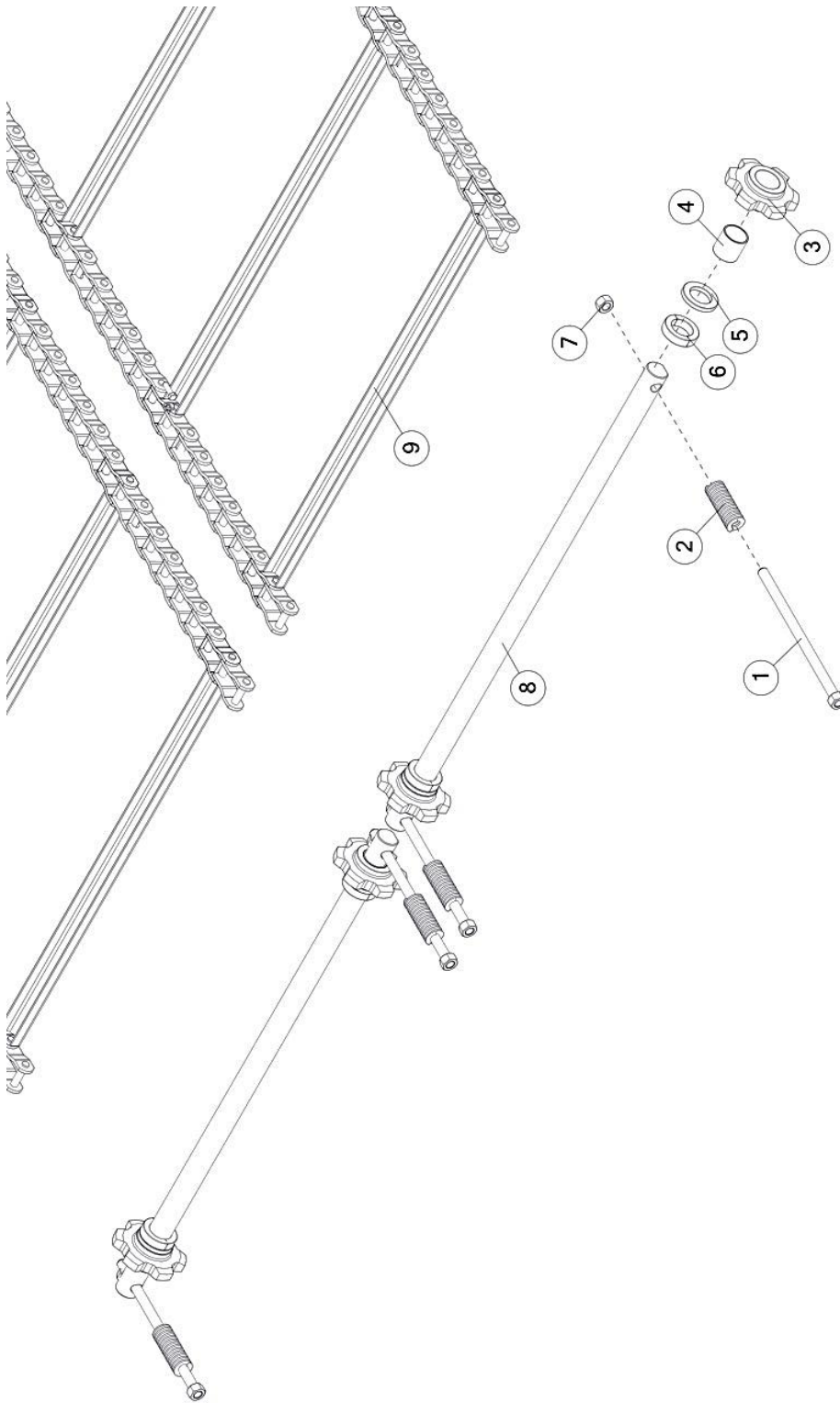

**FIGURE 4**  
**FLOOR & COMPONENTS**

<b><u>ITEM</u></b>	<b><u>QTY</u></b>	<b><u>PART #</u></b>	<b><u>DESCRIPTION</u></b>
1	9	YNNY12005	HEX NUT, NYLON LOCKNUT, 3/8
2	9	YWFL12005	WASHER, FLAT, 3/8 USS
3	1	72811	TD FRONT COVER, BRKT, STAINLESS
4	1	72813	TD MID COVER, BRKT, STAINLESS
5	5	72870	REAR COVER, BRKT, STAINLESS
6	2	TD26PL01	TD26 POLY FLOOR

# FIGURE 5

## FRONT IDLER SHAFT ASSEMBLY

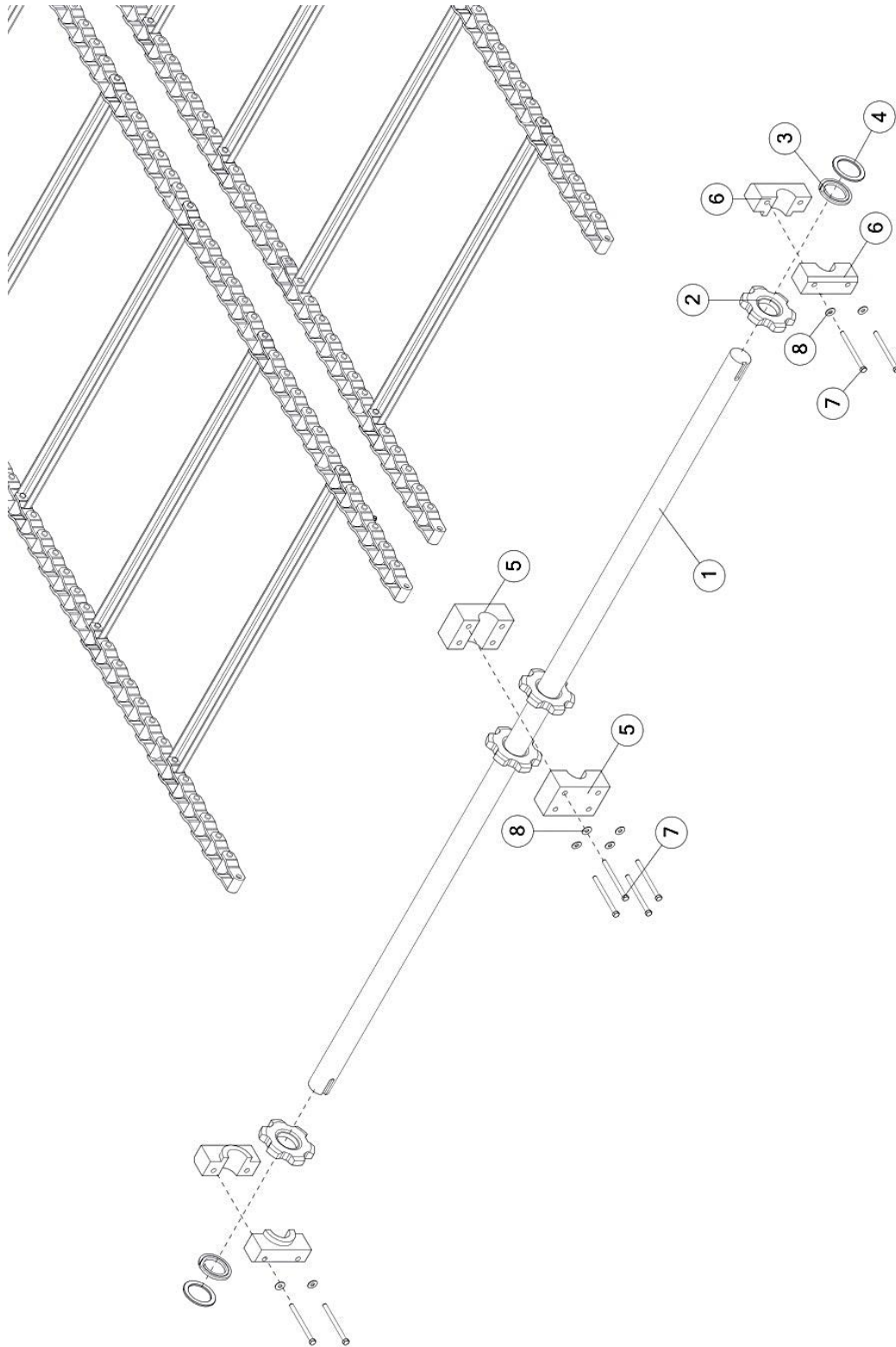

**FIGURE 5**  
**FRONT IDLER SHAFT ASSEMBLY**

<b><u>ITEM</u></b>	<b><u>QTY</u></b>	<b><u>PART #</u></b>	<b><u>DESCRIPTION</u></b>
1	4	BBS34	TIGHTENER ROD
2	4	BBS35	COMPRESSION SPRING
3	4	BBSTSH07	6 TOOTH IDLER SPROCKET
4	4	RGT3	BUSHING TANDEM 1-3/4"ID X 2"OD X 2"
5	4	BBSTPL05	IDLER SPROCKET POLY SPACER
6	4	8340	CLAMP COLLAR
7	4	YNHX24004	HEX NUT, 3/4-10 GR 5 ZINC
8	2	BBS29	IDLER SHAFT FRONT
9	2	8235	APRON CHAIN 240 PITCH

# FIGURE 6

## REAR IDLER SHAFT ASSEMBLY

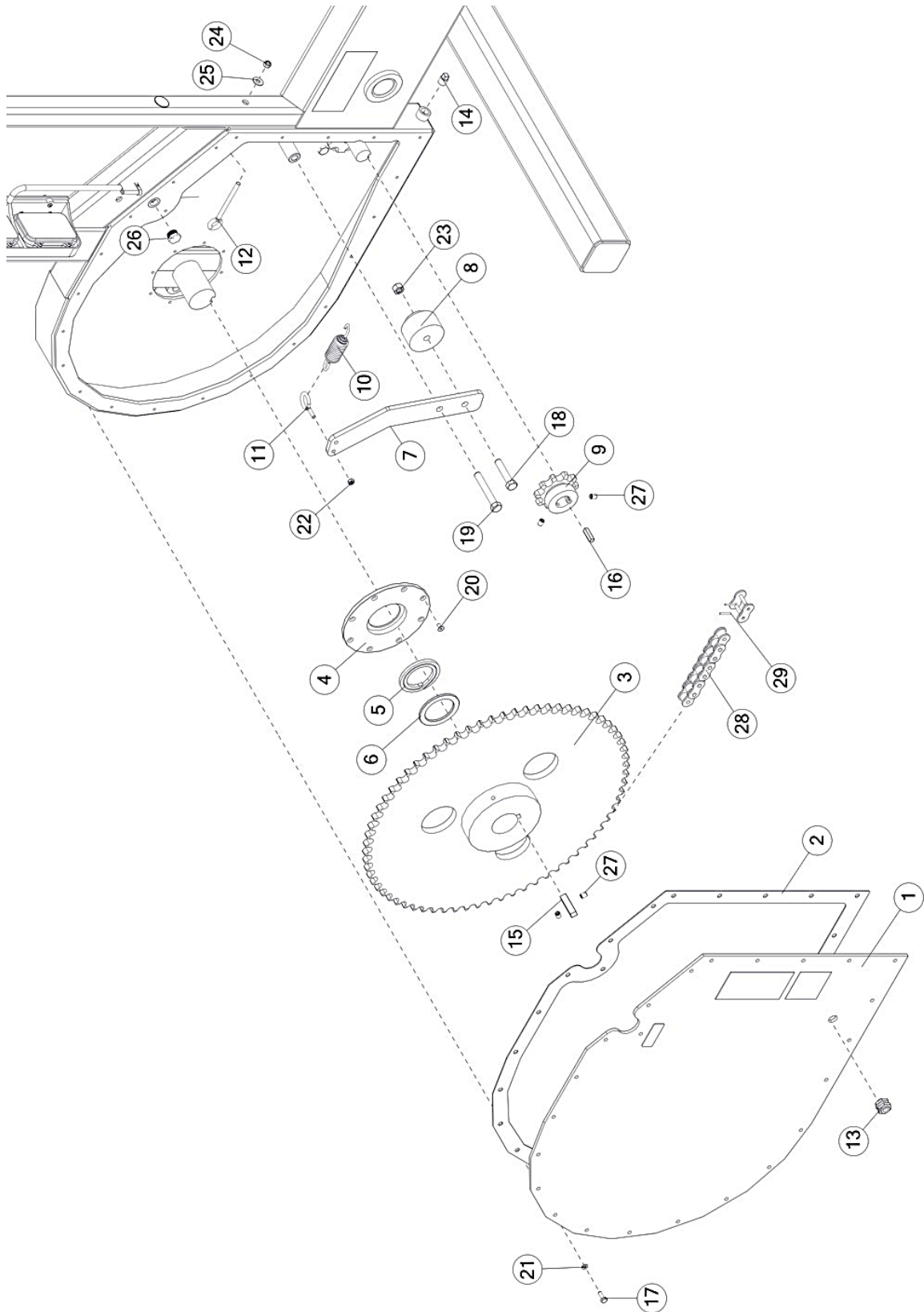

**FIGURE 6**  
**REAR IDLER SHAFT ASSEMBLY**

<b><u>ITEM</u></b>	<b><u>QTY</u></b>	<b><u>PART #</u></b>	<b><u>DESCRIPTION</u></b>
1	1	BBSTWE04	DRIVE SHAFT
2	4	BBSTSH04	6 TOOTH SPROCKET
3	2	BBSTMS23	ROPE SEAL
4	2	BBSTTU27	SEAL RETAINER PLATE
5	2	BBS62	DRIVE SHAFT BEARING CENTER
6	4	BBS63	OUTER DRIVESHAFT BEARING
7	8	YBHH12200	BOLT, HEX, 3/8-16 X 5, G5, ZC
8	8	YWFL12005	WASHER, FLAT, 3/8 USS

# FIGURE 7

## DRIVE SPROCKET ASSEMBLY (RIGHT SIDE)





## FIGURE 7

### DRIVE SPROCKET ASSEMBLY (RIGHT SIDE)

<u>ITEM</u>	<u>QTY</u>	<u>PART #</u>	<u>DESCRIPTION</u>
1	1	BBST3G19	SPROCKET COVER
2	1	BBSTMS13	SPROCKET COVER GASKET
3	1	BBS60	DRIVEN SPROCKET
4	1	BBSTHF19	BBST SEAL PLATE
5	1	BBSTMS23	BBST ROPESEAL
6	1	BBSTTU27	BBST SEAL RETAINER PLATE
7	1	BBS9	TIGHTENER BAR
8	1	BBS10	POLY TIGHTENER
9	1	BBS61	DRIVE SPROCKET
10	1	GM410	EXTENSION SPRING
11	1	YBTE08005	TURNED EYE BOLT, 1/4 X 1 FULL THREAD
12	1	YBTE10040	TURNED EYE BOLT, 5/16-18 X 4"
13	1	56092	1/4 NPT THROUGH-WALL FITTING
14	1	G65	PLUG, PIPE .38-18 NPT
15	1	BBS59	.500 X 2.000 HARDENED KEY
16	1	G23A	SQUARE KEY, 5/16 X 1-1/4"
17	23	YBHH08100	BOLT, HEX, 1/4-20 X 3/4, G5, ZC
18	1	YBHH16080	BOLT, HEX, 1/2-13 X 2-1/2, G5, ZC
19	1	YBHH16115	BOLT, HEX, 1/2-13 X 3-1/2, G5, ZC
20	8	YSFM08005	FLAT HEAD SOCKET CAP SCREW, 1/4-28 X 1/2
21	23	YWLO08005	WASHER, LOCK, 1/4
22	8	YNHX08005	HEX NUT, 1/4
23	1	YNHX16005	HEX NUT, 1/2-13 GR. 2
24	1	YNNY10005	HEX NUT, NYLON LOCKNUT, 5/16-18
25	1	YWFL10005	WASHER, FLAT, 5/16 USS
26	1	BFR70	VENT PLUG 3/8" #BV-3
27	4	YSKP12010	SET SCREW, SOCKET, KNURLED CUP PT, 3/8-16 X 1/2
28	1	1042	H80 X 81 PITCH ROLLER CHAIN ASSEMBLED
29	1	IFB17	#80 CONNECTOR LINK (HEAVY)

# **FIGURE 8** **DRIVE SPROCKET ASSEMBLY (LEFT SIDE)**

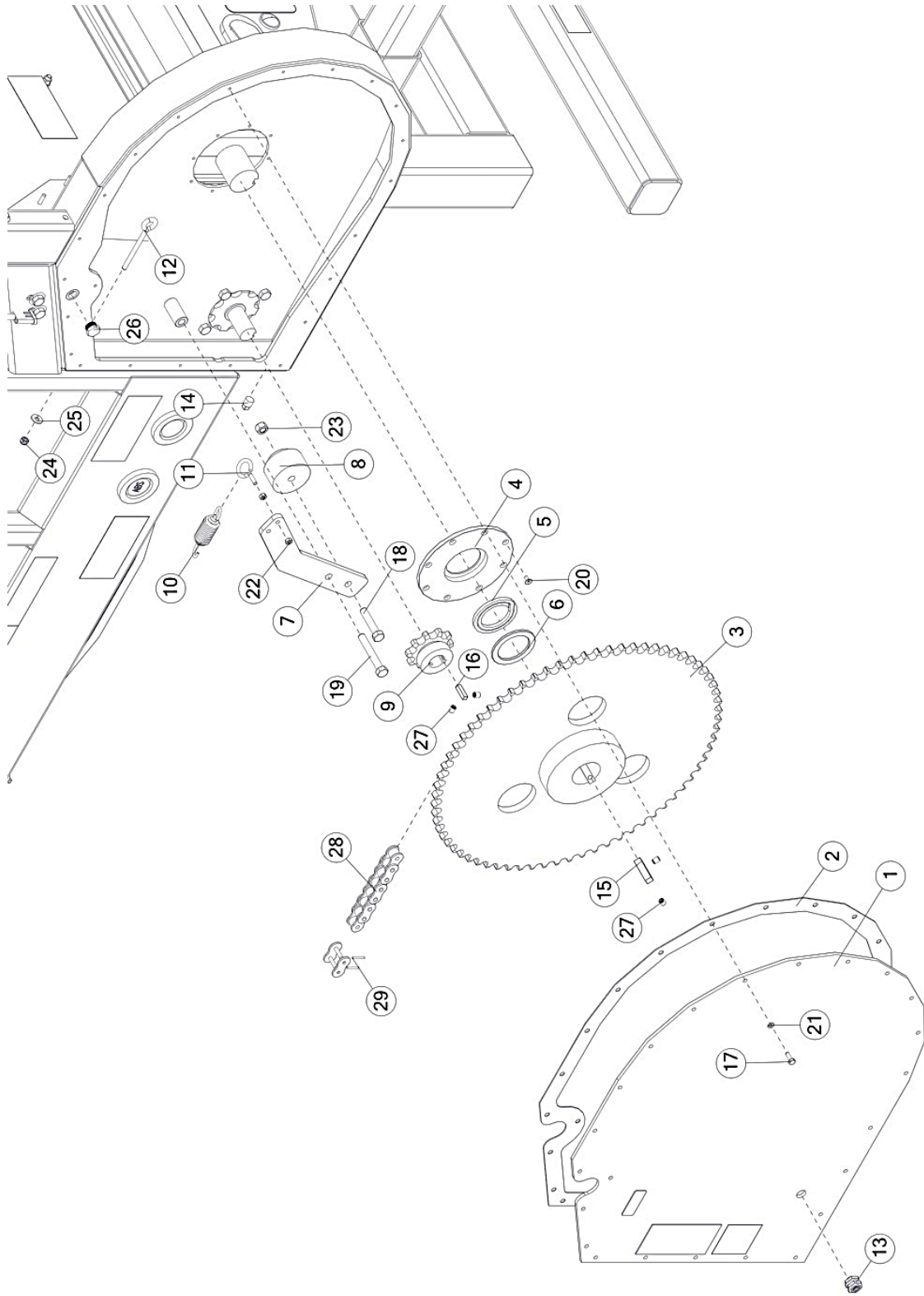

## FIGURE 8

### DRIVE SPROCKET ASSEMBLY (LEFT SIDE)

<u>ITEM</u>	<u>QTY</u>	<u>PART #</u>	<u>DESCRIPTION</u>
1	1	BBSTAS14	SPROCKET COVER LEFT
2	1	BBSTMS13	SPROCKET COVER GASKET
3	1	BBS60	DRIVEN SPROCKET
4	1	BBSTHF19	BBST SEAL PLATE
5	1	BBSTMS23	BBST ROPESEAL
6	1	BBSTTU27	BBST SEAL RETAINER PLATE
7	1	BBS9	TIGHTENER BAR
8	1	BBS10	POLY TIGHTENER
9	1	BBS61	DRIVE SPROCKET
10	1	GM410	EXTENSION SPRING
11	1	YBTE08005	TURNED EYE BOLT, 1/4 X 1 FULL THREAD
12	1	YBTE10040	TURNED EYE BOLT, 5/16-18 X 4"
13	1	56092	1/4 NPT THROUGH-WALL FITTING
14	1	G65	PLUG, PIPE .38-18 NPT
15	1	BBS59	.500 X 2.000 HARDENED KEY
16	1	G23A	SQUARE KEY, 5/16 X 1-1/4"
17	23	YBHH08100	BOLT, HEX, 1/4-20 X 3/4, G5, ZC
18	1	YBHH16080	BOLT, HEX, 1/2-13 X 2-1/2, G5, ZC
19	1	YBHH16115	BOLT, HEX, 1/2-13 X 3-1/2, G5, ZC
20	8	YSFM08005	FLAT HEAD SOCKET CAP SCREW, 1/4-28 X 1/2
21	23	YWLO08005	WASHER, LOCK, 1/4
22	8	YNHX08005	HEX NUT, 1/4
23	1	YNHX16005	HEX NUT, 1/2-13 GR. 2
24	1	YNNY10005	HEX NUT, NYLON LOCKNUT, 5/16-18
25	1	YWFL10005	WASHER, FLAT, 5/16 USS
26	1	BFR70	VENT PLUG 3/8" #BV-3
27	4	YSKP12010	SET SCREW, SOCKET, KNURLED CUP PT, 3/8-16 X 1/2
28	1	1042	H80 X 81 PITCH ROLLER CHAIN ASSEMBLED
29	1	IFB17	#80 CONNECTOR LINK (HEAVY)

# FIGURE 9 HYDRAULICS

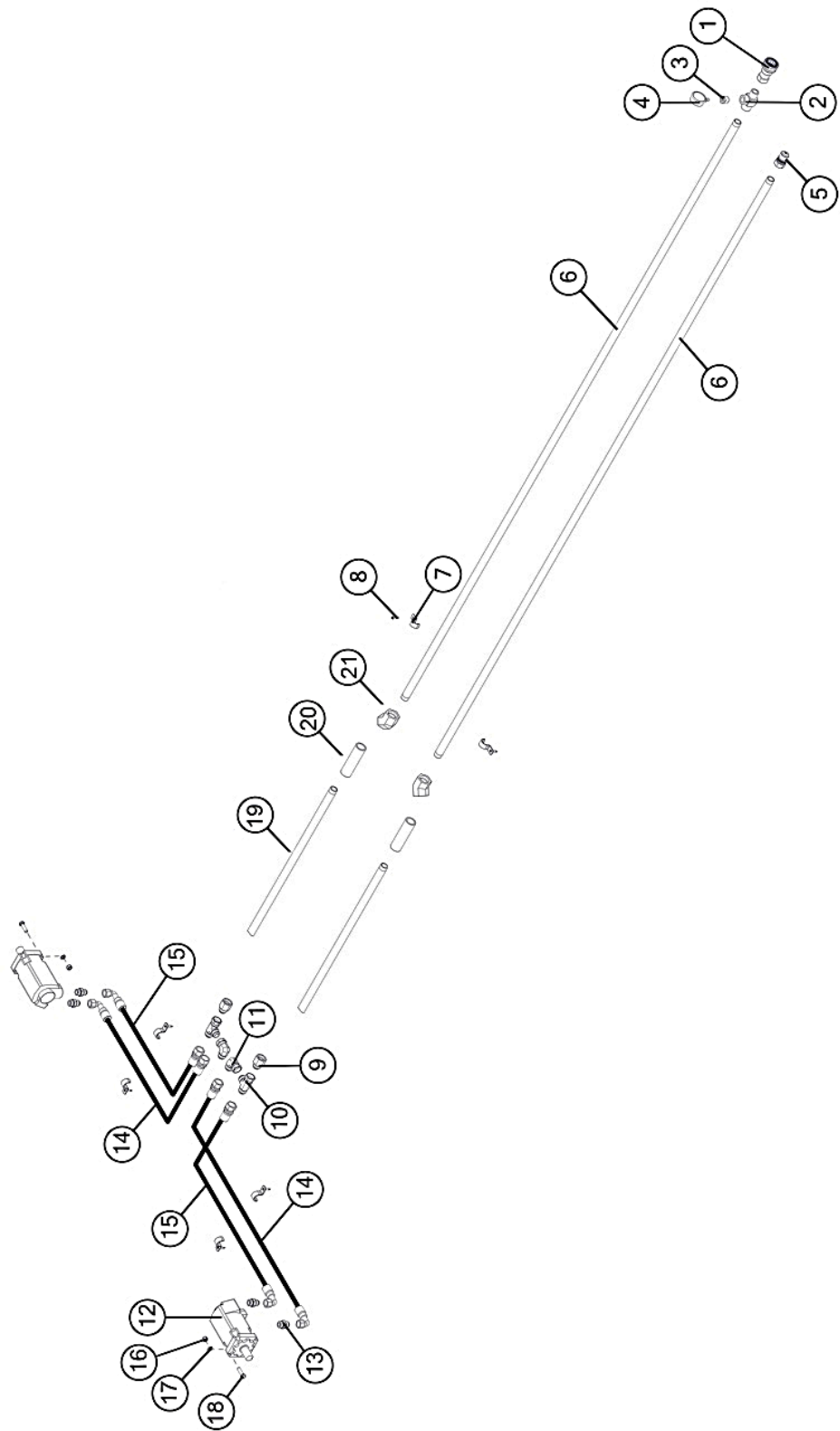

## FIGURE 9 HYDRAULICS

<u>ITEM</u>	<u>QTY</u>	<u>PART #</u>	<u>DESCRIPTION</u>
1	1	BBS31	1.00" QUICK COUPLER - FEMALE
2	1	DWM113	SERVICE TEE
3	1	BBS37	BUSHING, 1" NPTF TO 1/4" NPTF
4	1	BBS33	4000 PSI GAUGE
5	1	BBS32	1.00" QUICK COUPLER - MALE
6	2	BBSPT102	HYDRAULIC LINE
7	6	BBS86	PIPE CLAMP
8	6	YSDR66007	SELF DRILLING SCREW, HEX WASHER HEAD, #12 X 1-1/4
9	2	BBS65	FEMALE CONNECTOR
10	2	CHM182	SWIVEL NUT RUN TEE
11	2	8021	SWIVEL NUT ELBOW
12	2	33SV73	HYDRAULIC MOTOR 109-1105-006
*	2	61053	HYDRAULIC MOTOR SEAL KIT
13	4	54085	TD40 HYD LINE EXTENSION
14	2	BBSTMS17	HOSE, PRESSURE TO MOTOR
15	2	BBSTMS18	HOSE, MOTOR RETURN
16	8	YNSF16005	NUT, FLG, 1/2-13, LKSF, CH, ZC
17	8	YBHH16055	BOLT, HEX, 1/2-13 X 1-3/4, G5, ZC

**FIGURE 10**  
**GATE DELAY**

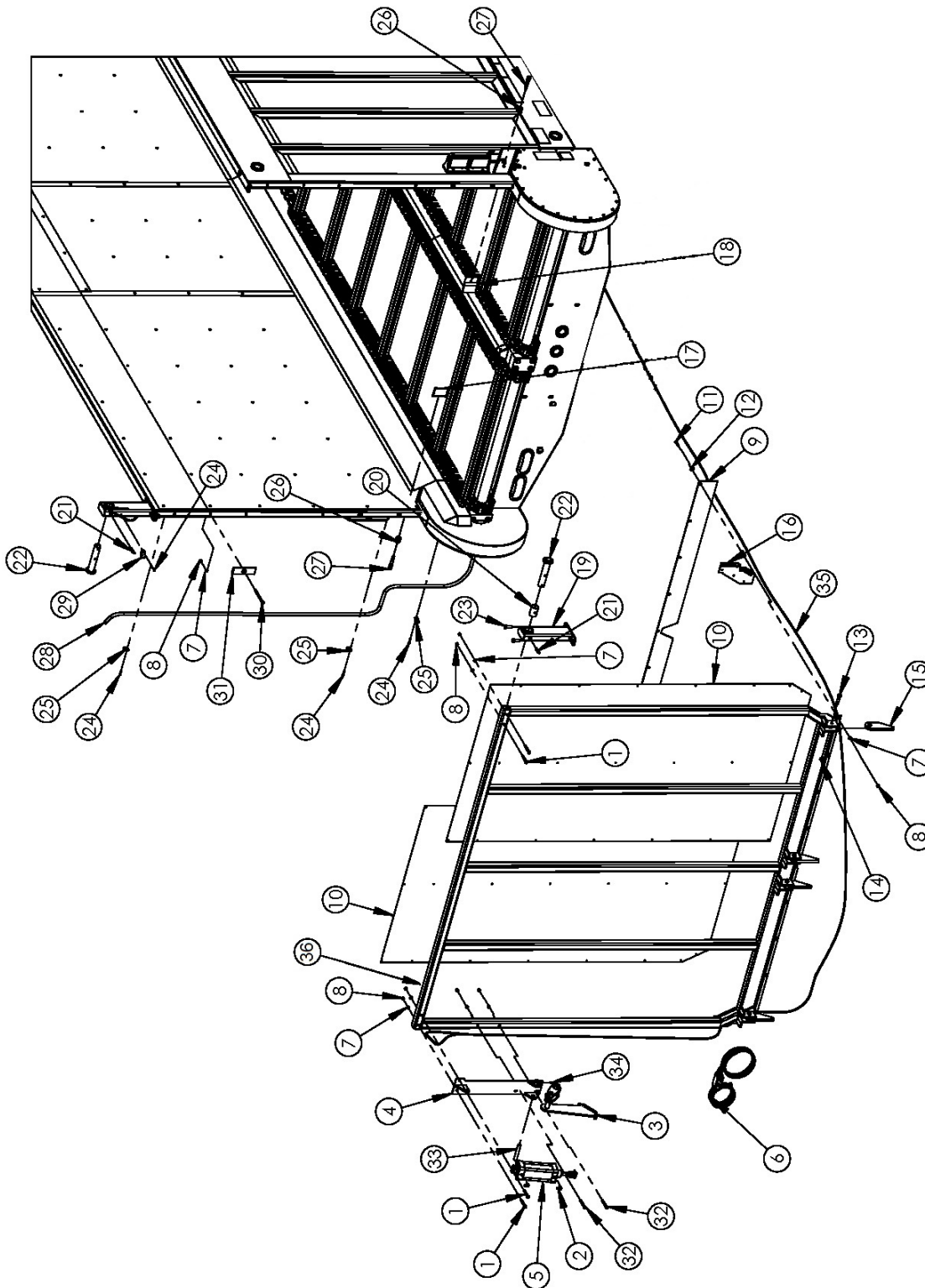

# FIGURE 10

## GATE DELAY

<u>ITEM</u>	<u>QTY</u>	<u>PART #</u>	<u>DESCRIPTION</u>
1	4	YBHH12110	BOLT, 3/8" X 2-3/4" GR. 5
2	2	GD5	MALE ELBOW, 1/4"
3	1	0231WE03	PIVOT
4	1	0231WE01	CYLINDER BASE PLATE
5	1	GD52	3-1/4" X 6" AIR CYLINDER COMPLETE
6	1	61598	HAND CONTROLLER (ON-OFF)
7	16	YWLO12005	WASHER, LOCK, 3/8"
8	16	YNHX12005	HEX NUT, 3/8"-16
9	1	BBS68	DOOR RUBBER
10	1	BBST16G06	DOOR SKIN, RH
*	1	61409	DOOR SKIN, LH
11	9	YBHH12035	BOLT, 3/8" X 1-1/4" GR. 5
12	9	YWFL12005	WASHER, FLAT, 3/8" USS
13	4	YBHH16080	BOLT, 1/2" X 2-1/2" GR. 5
14	4	YNTL16005	HEX NUT, TOP LOCK, 1/2"-13
15	4	BBS67	LATCH
16	2	55902	CORNER DOOR SEAL
17	1	55970	ROADSIDE DOOR STOP
18	1	56155	CURBSIDE DOOR STOP
19	2	BBS20	STAKE TOP REAR ASSEMBLY
20	2	56244	BUSHING, DRIVE SHAFT
21	2	16SV26	1/8" NPT X 2-3/32" 30 DEGREE ZERK
22	2	BBS64	DOOR HINGE PIN
23	4	YBHH16030	BOLT, 1/2" X 1-1/2" GR. 5
24	4	YSDR66007	SELF DRILLING SCREW, HEX WASHER HEAD, #12 X
25	3	1097	1-1/4" (ZINC) 1/2" EMT CLAMP
26	4	YWFL16005	WASHER, FLAT, 1/2" USS
27	4	YBHH16085	BOLT, 1/2" X 2-1/2" GR. 5 FULL THREAD
28	1	0227MS01	AIR LINE SHIELD
29	1	HGV72	SMALL TUBE HOLDER
30	1	YBCR12122	CARRIAGE BOLT, 3/8" X 5-1/2"
31	1	0231PL01	POLY BUMPER
32	2	YBHH12120	BOLT, 3/8" X 3" GR. 5
33	1	0231SH02	PIVOT PIN
34	1	YPEX08015	EXPANSION PIN, 1/4" X 1-3/4"
35	2	55852	CYLINDER SUPPLY LINE 530" (BLACK)
36	1	BBS38	DOOR ASSEMBLY

# FIGURE 11

## AIR CONNECTION

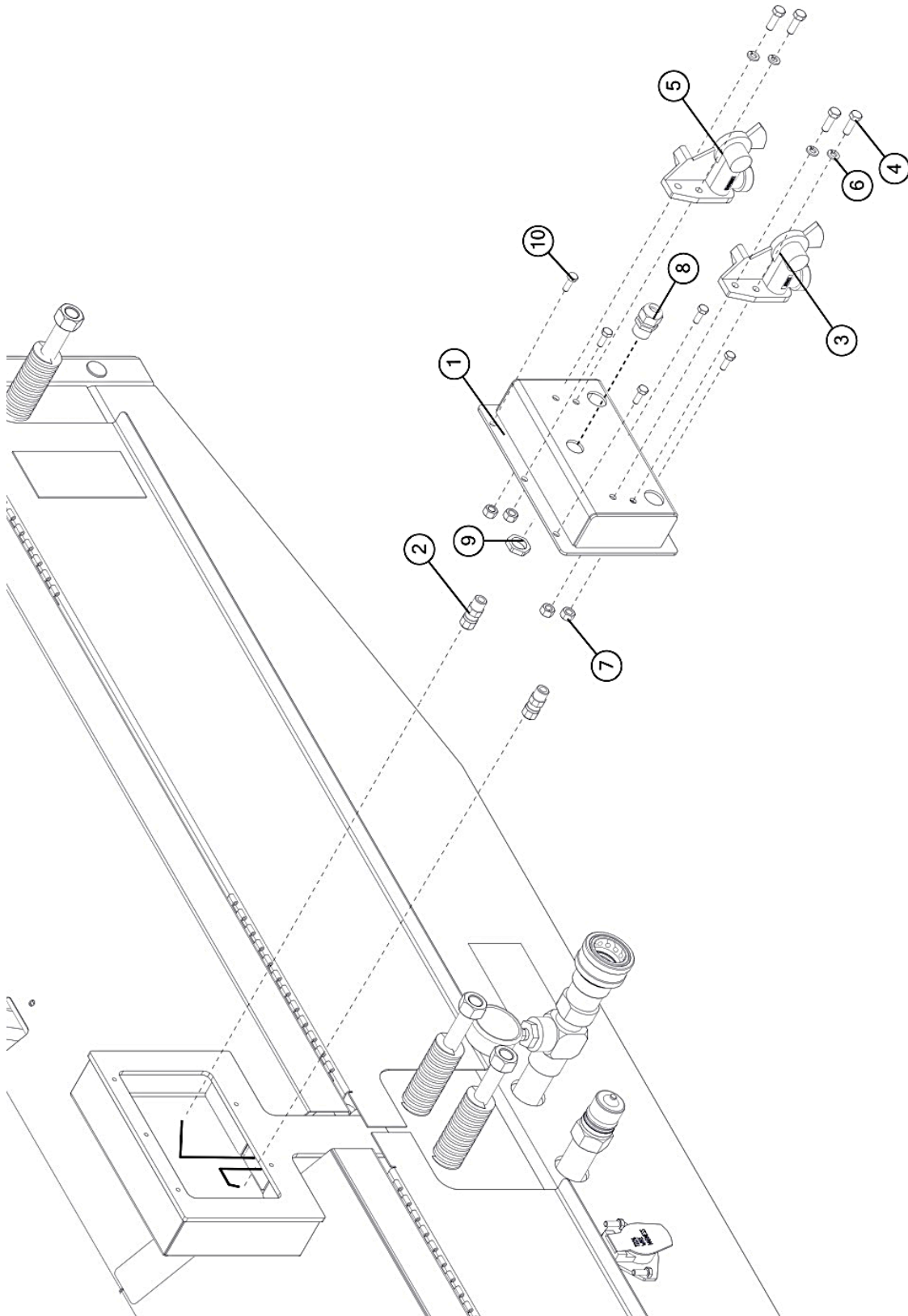



# **FIGURE 11**

## **AIR CONNECTION**

<b><u>ITEM</u></b>	<b><u>QTY</u></b>	<b><u>PART #</u></b>	<b><u>DESCRIPTION</u></b>
1	1	BBSTWE27	NOSE BOX
2	2	1032	3/8" MALE CONNECTOR (D.O.T.)
3	1	1015	37 DEGREE EMERGENCY GLADHAND
4	4	YBHH10010	BOLT, 5/16" X 1" GR. 5
5	1	1014	37 DEGREE SERVICE GLADHAND
6	4	YWLO10005	5/16" LOCK WASHER GR. 5
7	4	YNHX10010	HEX NUT, 5/16"-18 GR. 5
8	1	GD23	STRAIN RELIEF (CONNECTOR)
9	1	56120	STRAIN RELIEF LOCK NUT
*	1	BBSTAS16	NOSE BOX ASSEMBLY
10	5	YBHH08100	BOLT, 1/4" X 3/4" GR. 5

**NOTE: \* MEANS NOT SHOWN**

# **FIGURE 12**

## **REAR TRANSPORT LIGHTING**

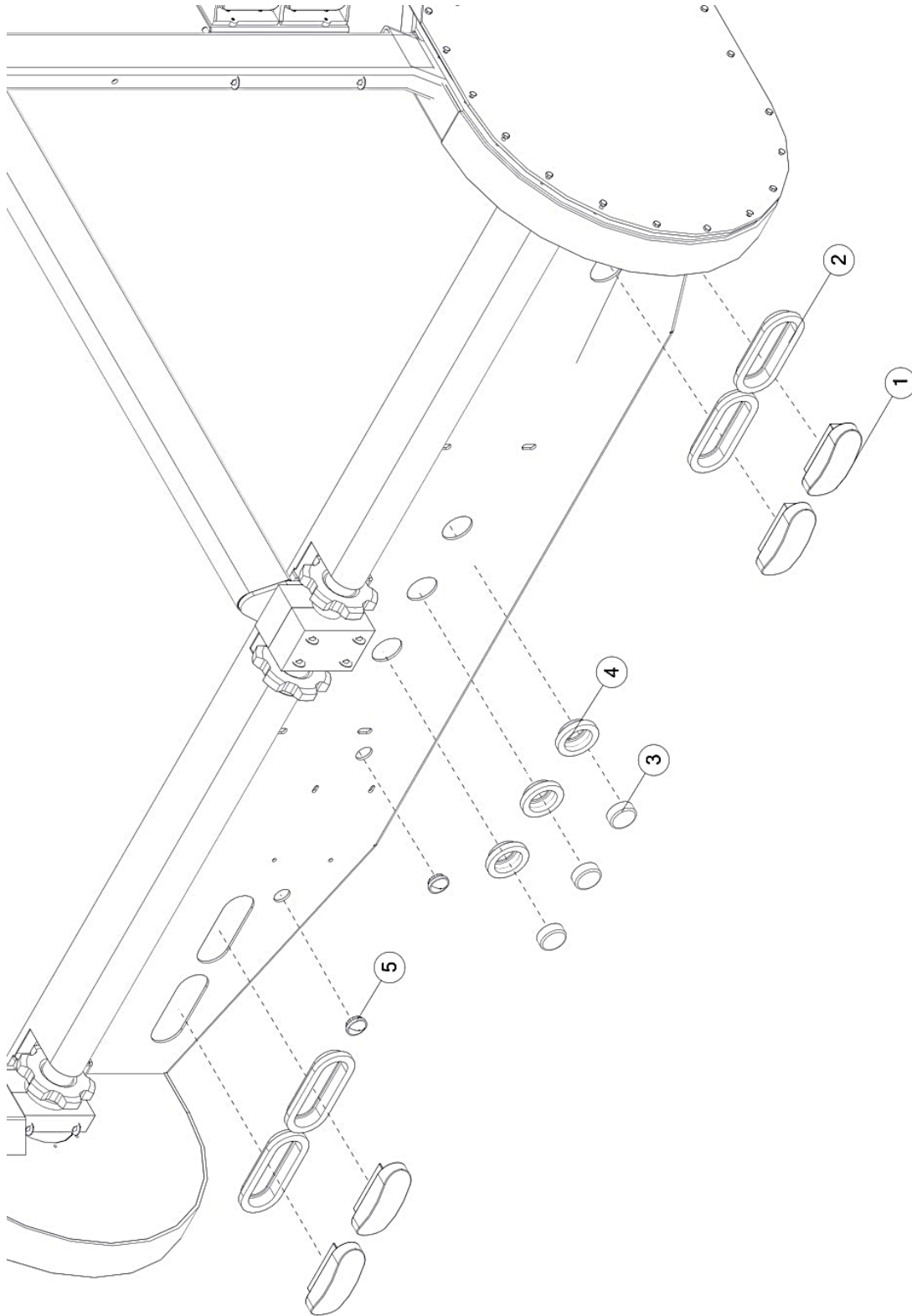

## **FIGURE 12**

### **REAR TRANSPORT LIGHTING**

<b><u>ITEM</u></b>	<b><u>QTY</u></b>	<b><u>PART #</u></b>	<b><u>DESCRIPTION</u></b>
1	1	S310	RED TAIL LIGHT
2	2	S308	GROMMET, RUBBER, OVAL LIGHT
3	1	BBS92	MARKER LIGHT, RED ROUND
4	4	BBS91	GROMMET ROUND
5	1	BBS98	LICENSE LIGHT

# FIGURE 13

## TRANSPORT LIGHTING

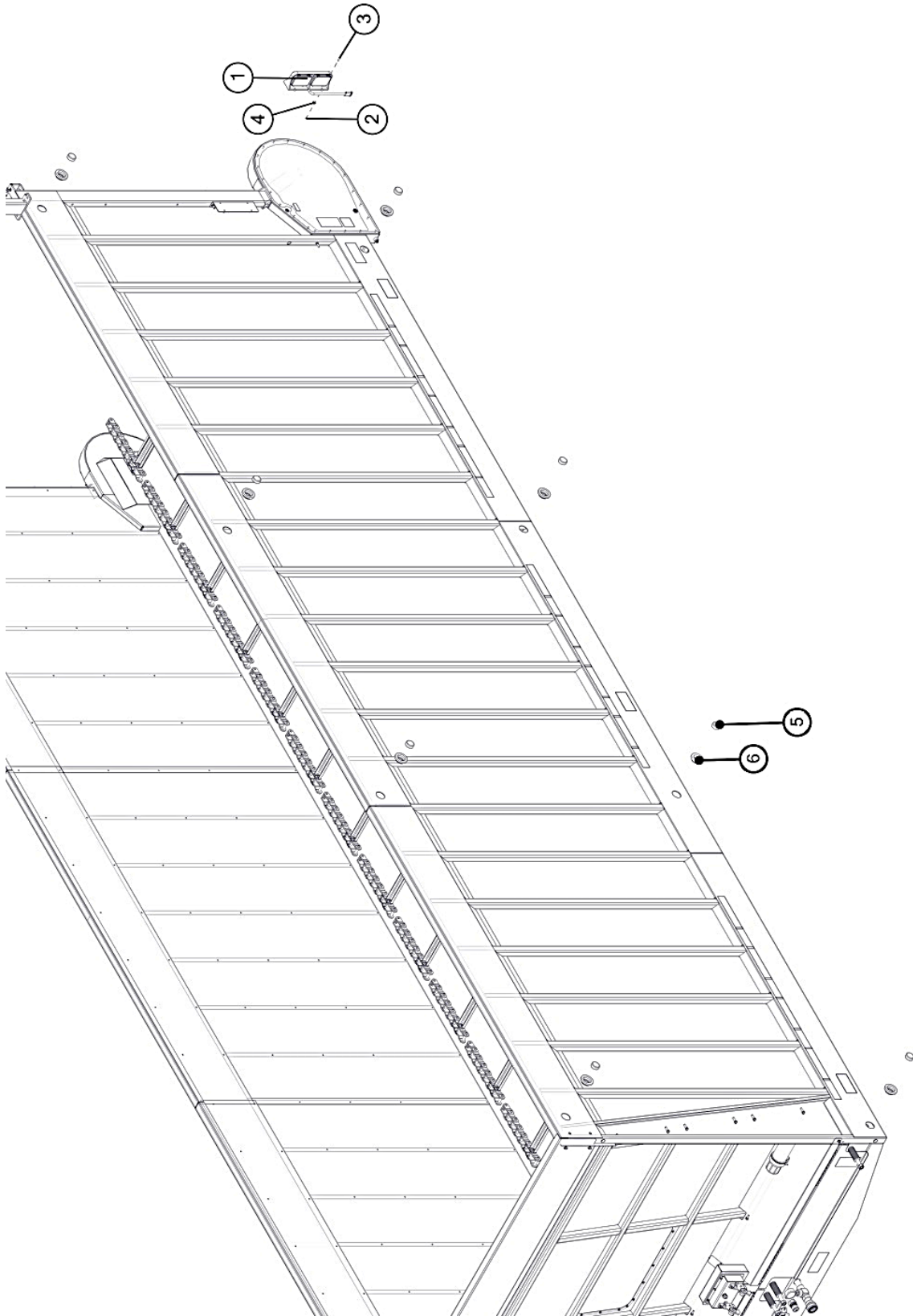

## **FIGURE 13**

### **TRANSPORT LIGHTING**

<b><u>ITEM</u></b>	<b><u>QTY</u></b>	<b><u>PART #</u></b>	<b><u>DESCRIPTION</u></b>
1	1	TFM71	LED TAIL LIGHT ASSY. LEFT
*	1	TFM72	LED TAIL LIGHT ASSY. RIGHT
2	1	YNHX64005	NUT, HEX, MACHINE, #10-32, NA, ZC
3	1	YSPP64010	#10-32 X 1" PHILLIPS HEAD MACHINE SCREW
4	1	YWSI64005	WASHER, LOCK, STAR, INTERNAL/EXTERNAL, #10 (ZINC)
5	16	BBS93	MARKER LIGHT, AMBER ROUND
6	16	BBS91	GROMMET ROUND

**NOTE: \* MEANS NOT SHOWN**

# FIGURE 14

## OPTONAL BARN DOORS

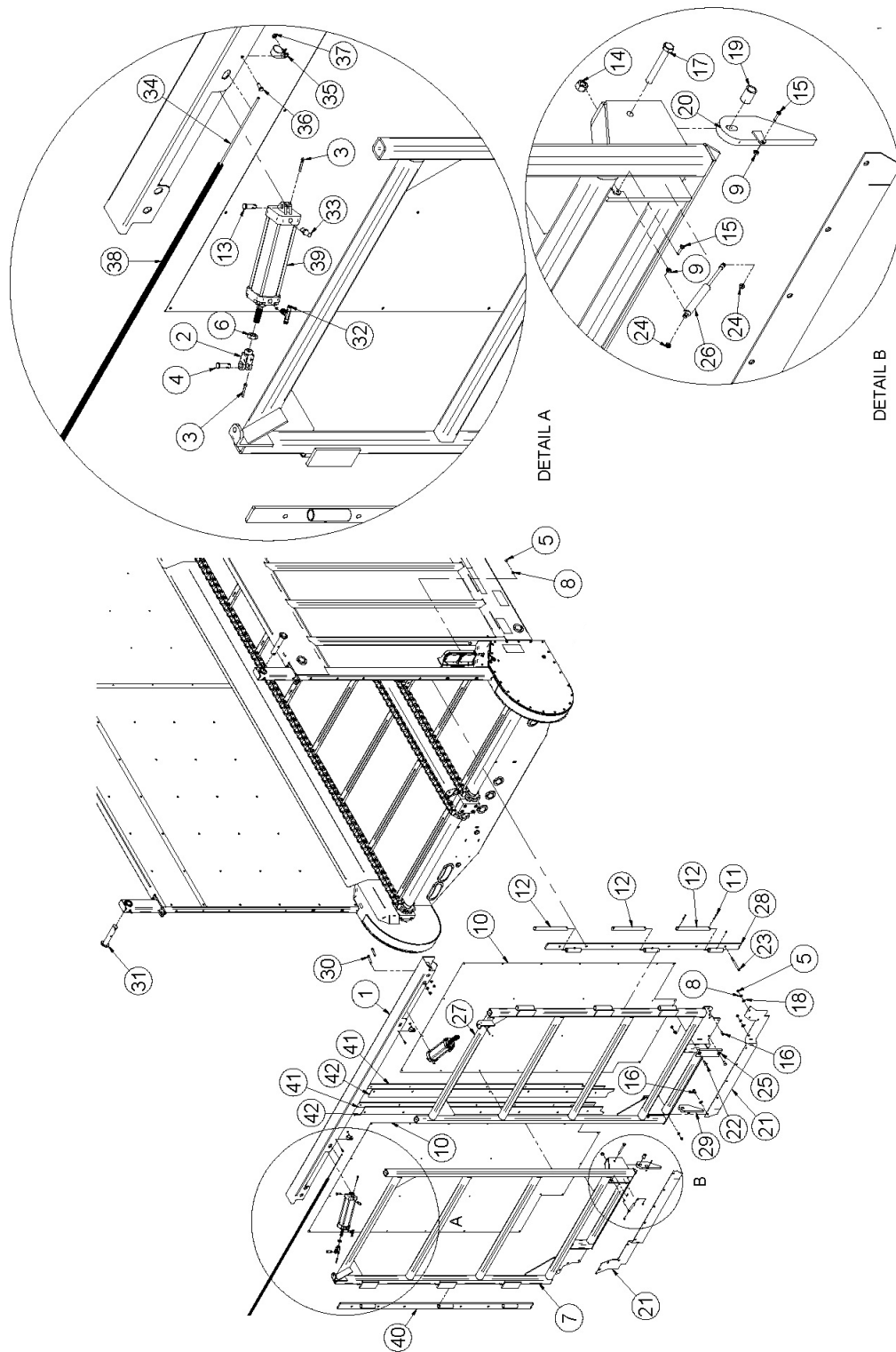

## FIGURE 14

### OPTIONAL BARN DOORS

<u>ITEM</u>	<u>QTY</u>	<u>PART #</u>	<u>DESCRIPTION</u>
1	1	0227WE01	TOP CHANNEL
2	2	8542	.625-18 CLEVIS
3	2	YPCT05005	COTTER PIN, 5/32" X 1"
4	2	8544	1/2 DIA X 1-1/2 CLEVIS PIN
*	1	56264	CLEVIS ASSEMBLY (INCLUDES ITEM # 2, 3 & 4)
5	2	8543	1/2 DIA X 1-3/8 CLEVIS PIN
6	2	YNJM20010	HEX NUT, JAM, 5/8"-18
7	1	0227WE04	DOOR LEFT
8	34	YWLO12005	LOCK WASHER, 3/8",
9	2	YNHX62005	8-32 ZINC PLATED NUT
10	1	022716G01	DOOR PANEL, RH
*	1	66286	DOOR SKIN, LH
11	12	YPEX08015	EXPANSION PIN, 1/4 X 1 3/4
12	6	0227SH01	HINGE PIN
13	34	YNHX12005	HEX NUT, 3/8"-16
14	2	YNTL16005	HEX NUT, TOP LOCK, 1/2-13
15	2	1135	#8-32 x .75 MACHINE SCREW, PHILLIPS HEAD, ZINC PLATED
16	16	YBHH12010	3/8-16 x 1 HEX CAP SCREW GRADE 5
17	2	YBHH16115	BOLT, 1/2" X 3-1/2" GR. 5
18	34	YWFL12005	FLAT WASHER, 3/8", GR. 5
19	2	0227PI02	LATCH SPACER
20	1	0227WE07	LATCH LEFT
21	2	0227RU01	DOOR SEAL BOTTOM
22	4	YBCR12020	CARR. BOLT, 3/8" X 1-1/4" GR. 5
23	12	YBHH12200	BOLT, 3/8 X 5 GR 5
24	2	YNNY62005	8-32, HEX NYLON INSERT LOCKNUT
25	2	0227PL01	POLY BUMPER
26	2	SD190	GAS STRUT
27	1	0227WE05	DOOR RIGHT
28	1	0227WE03	STAKE HINGE RIGHT
29	1	0227WE08	LATCH RIGHT
30	4	YBHH12110	BOLT, 3/8" X 2-3/4" GR. 5
31	2	BBS64	DOOR HINGE PIN
32	2	GD26	MALE BRANCH TEE 1/4"
33	2	GD7	1/4" VENT PLUG (CONE SHAPED)
34	1	0227MS03	CYLINDER TIE AIR LINE
35	2	HGV72	WIRE CLAMP #12
36	2	YBHH08100	BOLT, 1/4 X 3/4 GR 5
37	2	YNHX08005	1/4"-20 TOP LOCK NUT
38	1	0227MS02	WIRE LOOM
39	2	GD49	2.5 AIR CYLINDER
40	1	0227WE02	STAKE HINGE LEFT
41	2	02273G05	DOOR SEAL HOLD DOWN
42	2	0227RU02	DOOR SEAL

**NOTE: \* MEANS NOT SHOWN**





## **FIGURE 15**

### **GRAIN KIT**

<b><u>ITEM</u></b>	<b><u>QTY</u></b>	<b><u>PART #</u></b>	<b><u>DESCRIPTION</u></b>
1	4	S308	LIGHT GROMMET, OVAL
2	4	S310	OVAL LIGHT, RED
3	3	BBS92	MARKER LIGHT, RED ROUND
4	3	BBS91	LIGHT GROMMET, ROUND
5	1	DWM324	SAFETY SNAP PIN
6	1	YBHH12100	BOLT, 3/8" X 2-1/4" GR. 5
7	9	YWFL12005	WASHER, FLAT, 3/8" USS
8	1	YNTL12005	HEX NUT, TOP LOCK, 3/8"-16
9	10	YBHH08010	BOLT, 1/4" X 1" GR. 5
10	1	GH7	HOPPER WINDOW
11	10	YWFL08005	WASHER, FLAT, 1/4" USS
12	10	YNNY08005	HEX NUT, NYLON LOCKNUT, 1/4"-20
13	1	0226RU02	UPPER HOPPER SEAL
14	1	BBS68	DOOR RUBBER
15	2	0226MS01	1-1/4" BRUSH HOLDER
16	2	0226MS04	2" BRUSH LONG
17	2	YBHH12130	BOLT, 3/8" X 3/4" GR. 2
18	4	YNHX12005	HEX NUT, 3/8"-16
19	1	GH8	FOLDING CRANK
20	1	0226WE04	REAR DOOR DRIVE
21	1	GH11	DRAG BLOCK TIGHTENER
22	1	0226WE02	SIDE EXTENSION RIGHT
23	1	0226WE03	SIDE EXTENSION LEFT
24	4	YBHH12200	BOLT, 3/8" X 5" GR. 5
25	1	GH4	REAR HOPPER DOOR
26	2	HGV162	1/2" RUBBER WIRE HOLDER

**FIGURE 16**  
**FLOW CONTROL KIT**

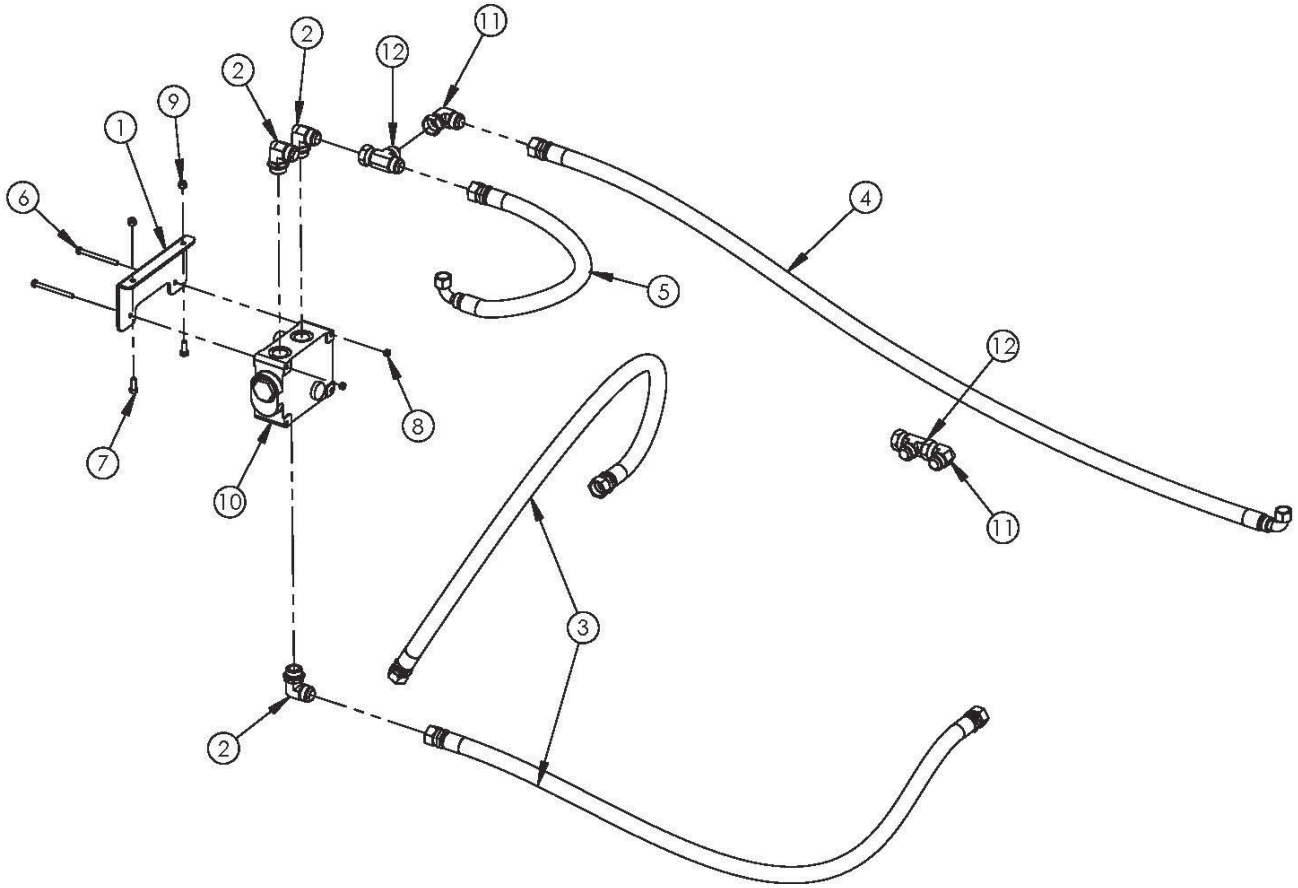

## FIGURE 16

### FLOW CONTROL KIT

<u>ITEM</u>	<u>QTY</u>	<u>PART #</u>	<u>DESCRIPTION</u>
1	1	02266G02	FLOW CONTROL MOUNT
2	3	BBS52	STRAIGHT THREAD ELBOW
3	2	BBSTMS24	PSI TO FLOW
4	1	BBSTMS25	HOSE, FLOW TO MOTOR, LONG
5	1	BBSTMS26	HOSE, FLOW TO MOTOR, SHORT
6	2	YBHH10112	BOLT, 5/16"-18 X 3-3/4" GR. 5
7	2	YBHH12010	BOLT, 3/8" X 1" GR. 5
8	2	YNHX10005	HEX NUT, 5/16"
9	2	YNNY12005	HEX NUT, NYLON LOCKNUT, 3/8"-16
10	1	BBS51	FLOW CONTROL
11	2	8021	SWIVEL NUT ELBOW
12	2	CHM182	SWIVEL NUT RUN TEE

**FIGURE 17**  
**AIR VALVE FOR GATE DELAY**

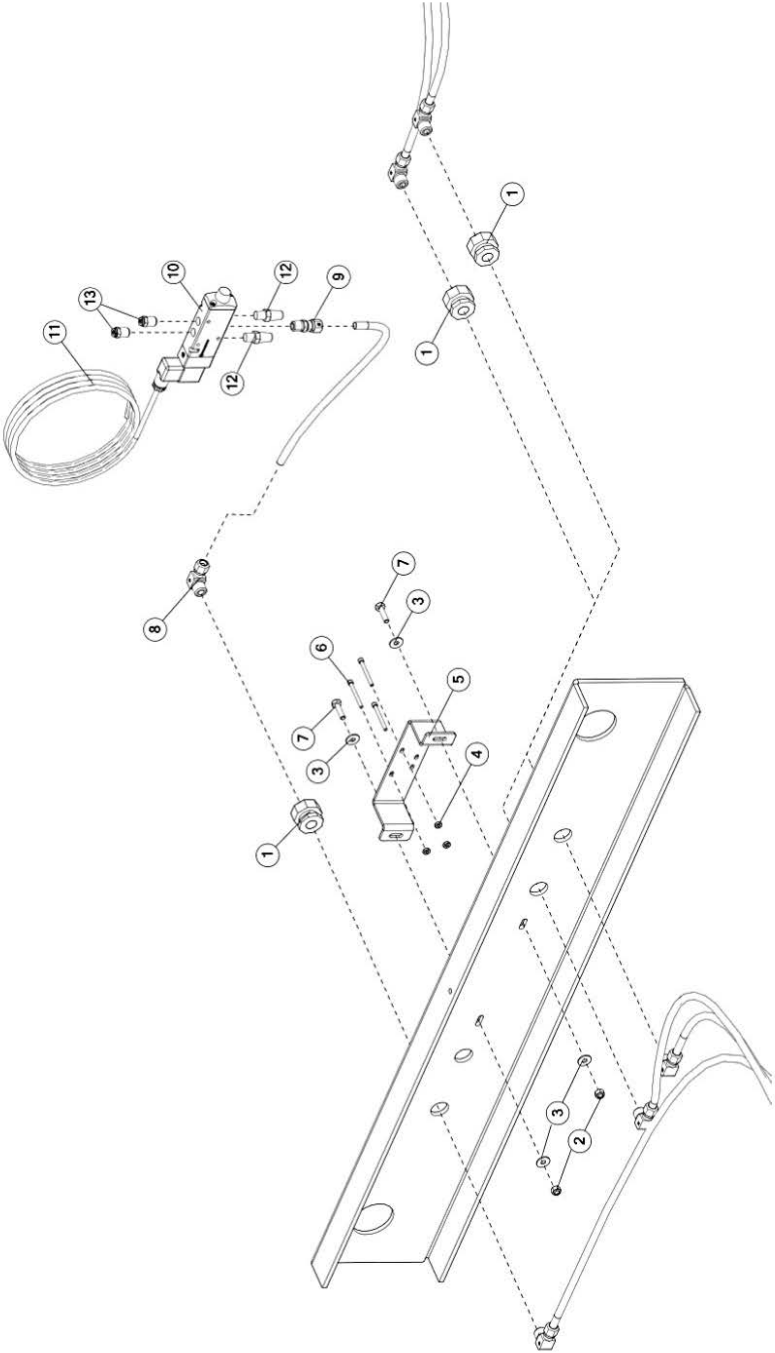

## **FIGURE 17**

### **AIR VALVE FOR GATE DELAY**

<b><u>ITEM</u></b>	<b><u>QTY</u></b>	<b><u>PART #</u></b>	<b><u>DESCRIPTION</u></b>
1	3	1114	3/8" x 3/8" BULKHEAD NIPPLE
2	2	YNNY08005	HEX NUT, NYLON LOCKNUT, 1/4-20
3	4	YWFL08005	WASHER, FLAT, 1/4 USS
4	3	YNHX62005	#8-32 ZINC PLATED NUT
5	1	54510	AIR VALVE MOUNTING BRACKET
6	3	YSHS62005	SOCKET HEAD CAP SCREW, #8-32 X 1-3/4 X 1.00
7	2	YBHH08010	BOLT, 1/4 X 1 GR 5
8	1	55798	MALE ELBOW, 3/8 NPT TO 3/8 COMP
9	1	58651	1/4" to 3/8" DOT FITTING
10	1	8031	GATE DELAY AIR VALVE (4 WAY)
11	2	1093	DIN CORD
12	2	GD7	1/4" VENT PLUG (CONE SHAPED)
13	2	GD6	MALE COUPLER





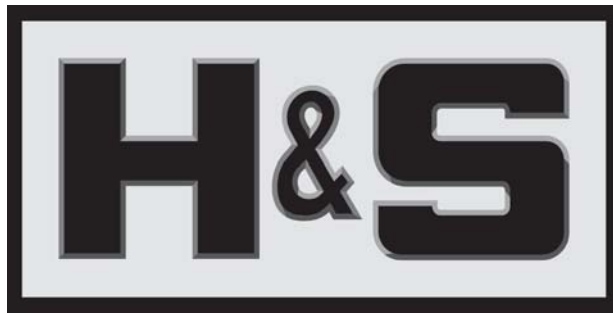

**H&S Manufacturing products are approved for the  
FEMA SEAL OF QUALITY**

**P.O. BOX 768, MARSHFIELD, WI 54449  
(715) 387-3414 FAX (715) 384-5463  
[www.hsmfgco.com](http://www.hsmfgco.com)**