



**5114/5116**

# **OPERATOR'S MANUAL**



## **WARNING**

**READ AND UNDERSTAND THIS MANUAL BEFORE OPERATING THIS EQUIPMENT. UNSAFE OPERATION OR MAINTENANCE OF THIS EQUIPMENT CAN RESULT IN SERIOUS INJURY OR DEATH.**

Revision #00  
5114 Starting Ser. # 612485

HSMFG0216

Part #72907

**Manufactured By**  
**H&S MANUFACTURING CO., INC.**

**P.O. BOX 768 (715) 387-3414 FAX (715) 384-5463**  
**MARSHFIELD, WISCONSIN 54449**

# **CONTENTS**

|   |                   |
|---|-------------------|
| Warranty & Warranty Registration Card .....                         | 1-2               |
| Manufacturers Statement .....                                       | 2                 |
| Dealer Pre-Delivery Checklist .....                                 | 3                 |
| Dealer Delivery Checklist .....                                     | 5                 |
| Safety Information - Be Alert Symbol .....                          | 7                 |
| Safety Information - Explanation of Safety Signs .....              | 8                 |
| Safety Decals .....   | 9                 |
| Safety Information - Warning - Owner Must Read and Understand ..... | 10                |
| Cap Screw Torque Values .....                                       | 11                |
| Set-up & Assembly .....   | 12                |
| Transporting .....  | 13                |
| Preparing for Operation .....                                       | 14                |
| Operation & Adjustments .....                                       | 15-16             |
| Optional Equipment .....  | 17                |
| Lubrication Guide .....   | 18                |
| Decal Location .....  | 19-23             |
| Trouble Shooting .....  | 24                |
| Service Notes .....   | 25-26             |
| Specifications .....  | Inside Back Cover |

# WARRANTY

## H&S WARRANTY

H&S Manufacturing Co., Inc. ("H&S") warrants this product to be free from defect in material and workmanship. Except as noted below, this warranty term is twelve (12) months from the date of delivery of the product to the original purchaser by an authorized H&S dealer. Under this warranty, H&S will repair or replace, at its option, any covered part which is found to be defective in material or workmanship during the applicable warranty term. In no case will the covered repair cost of a part or parts exceed the replacement cost of that part. Warranty service must be performed by H&S or a dealer authorized by H&S to sell and/or service the product involved, which will use only new or remanufactured parts or components furnished by H&S. This warranty includes approved parts and labor to fix the product but does not include, and the purchaser is responsible for, any service call and/or transportation of the product to and from the dealer's place of business, for any premium charged for overtime labor requested by the purchaser, and for any service work not directly related to any defect covered under this warranty. This warranty includes only those components of the product manufactured by H&S. Warranty for any component not manufactured by H&S including, but not limited to, engines, batteries, tires, rims, hydraulic motors, pumps, etc. are covered by the warranty, if any, provided separately by their respective manufacturers.

This warranty in all its parts, is extended solely to the original purchaser of the product, is terminated upon any subsequent transfer or sale from or by the original purchaser and extends no third party benefits or rights whatsoever.

The warranty term for any product used in any commercial, custom, for hire or rental application, is limited to six (6) months from the date of delivery of the product to the original purchaser or the first day of service, whichever comes first, by an authorized H&S dealer.

Floor and side panels utilized in H&S Manure Spreaders are warranted, to the original purchaser, to not wear through or delaminate for 10 years when used to spread normal agricultural manure. The frame, sides, end, floor and roof of forage boxes are warranted to not wear or rust through for 10 years when the forage box is used to transport freshly chopped forage. These specific warranties include only replacement of any defective panel part without any allowance for labor beyond the terms of the standard H&S 12 month warranty.

For commercial, custom for hire, or rental application, warranty is limited to 6 months from the date of delivery to the original purchaser, or the first day in service, whichever is earlier.

This warranty does not include: (1) Any product that has been altered or modified in ways not approved by H&S; (2) Depreciation or damage caused by normal wear, misuse, improper or insufficient maintenance, improper operation, accident or failure to follow the product Operator's Manual recommendations and product decal recommendations; (3) Normal maintenance parts and service; (4) Repairs made with parts other than those available from H&S or performed by anyone other than H&S or a dealer authorized by H&S to sell and/or service the product involved.

To secure warranty service the purchaser must report the product defect to a dealer authorized by H&S to sell and/or service the product involved within the applicable warranty term together with evidence of the warranty start date and make the product available to that dealer within a reasonable period of time.

**HERE ARE NO WARRANTIES WHICH EXTEND BEYOND THE DESCRIPTION ON THE FACE OF THIS WARRANTY.** H&S and the companies affiliated with it makes no warranties, representations, or promises, express or implied, as to the performance or freedom from defect of its products other than those set forth above and **NO IMPLIED WARRANTY OF MERCHANTABILITY, FITNESS OR FITNESS FOR A PARTICULAR PURPOSE IS MADE. IN NO EVENT WILL THE DEALER, H&S OR ANY COMPANY AFFILIATED WITH H&S BE LIABLE FOR INCIDENTAL OR CONSEQUENTIAL DAMAGES.** The **ONLY REMEDY** the purchaser has in connection with the breach of performance of any warranty on H&S products are those set forth above.

The selling dealer has no authority to make any representation or promise on behalf of H&S, or to modify the terms or limitations of this warranty in any way.

12/13

**FILL OUT  
AND MAIL  
IMMEDIATELY  
TO MAKE  
WARRANTY  
EFFECTIVE**



### WARRANTY REGISTRATION

Date of Purchase \_\_\_\_\_

Purchaser \_\_\_\_\_ Address \_\_\_\_\_

City \_\_\_\_\_ State \_\_\_\_\_ Zip \_\_\_\_\_

Product \_\_\_\_\_ Model# \_\_\_\_\_ Serial# \_\_\_\_\_

Dealer \_\_\_\_\_ Address \_\_\_\_\_

City \_\_\_\_\_ State \_\_\_\_\_ Zip \_\_\_\_\_

\_\_\_\_\_  
Signature of Original Buyer

# **MANUFACTURER'S STATEMENT**

Your New H&S Product has been manufactured of the finest quality materials and components. The performance you get from your machine is largely dependent upon how well you read and understand this manual and apply this knowledge. There is a right and a wrong way to do everything. Please do not assume that you know how to operate and maintain your Machine before reading this manual carefully. Keep this manual available for ready reference.

## **IMPORTANT!**

Tear on the dotted line, provide the information requested on the card. The H&S Warranty is valid **“only”** after this card is received and recorded at H&S Manufacturing Co., Inc. Mail at once. No postage is required in the U.S.A.



NO POSTAGE  
NECESSARY  
IF MAILED  
IN THE  
UNITED STATES

### **BUSINESS REPLY MAIL**

FIRST CLASS MAIL Permit No.195 Marshfield, WI 54449

POSTAGE WILL BE PAID BY ADDRESSEE

**H&S Manufacturing Co., Inc.**  
PO Box 768  
Marshfield, WI 54449-9963



# DEALER PRE-DELIVERY CHECK LIST

## **AFTER COMPLETION, DEALER SHOULD REMOVE AND RETAIN FOR RECORDS**

After the rake has been completely set-up, check to be certain it is in correct operating order before delivering to the customer. The following is a list of points to inspect. Check off each item as you have made the proper adjustments and found the item operating satisfactorily.

- Rake was not damaged in shipment. Check for dents and loose or missing parts. Report damage immediately to H&S Manufacturing Co., Inc.
- Rake has been correctly assembled according to instructions in this manual. Wheel nuts and all other fasteners are tightly secured.
- All bolts and fasteners are tight.
- All grease fittings have been lubricated. See Lubrication Chapter of this manual for details.
- Hoses and fittings are properly attached and there are no visible leaks.
- All mechanisms are operating trouble free.
- Rake wheels touch ground in unison when lowered into position. (Rake setting level)
- Wheels are properly mounted.
- Tires are inflated to correct pressure.
- Decals are in place and legible.

Model Number \_\_\_\_\_

Serial Number \_\_\_\_\_

Dealer's Name \_\_\_\_\_

Inspection Date \_\_\_\_\_

Signature of Pre-Delivery Inspector \_\_\_\_\_

(Remove Dealers File Copy At Perforation)

**Intentionally Left Blank**

# DEALER DELIVERY CHECK LIST

## **AFTER COMPLETION, DEALER SHOULD REMOVE AND RETAIN FOR RECORDS**

This check list that follows is an important reminder of valuable information that should be passed on to the customer at the time this Rake is delivered.

Check off each item as you explain it to the customer.

This delivery check list, when properly filled out and signed assures the customer that the Pre-delivery service was satisfactorily performed.

- Explain to the customer that the pre-delivery inspection was made.
- Explain to the customer all the safety precautions they must exercise when operating this unit.
- Explain raking and windrow width adjustments.
- Explain to customer that regular lubrication is required for proper operation and long life of machine.
- Show customer the lubrication section of Owner's Manual.
- Give the customer Owner's Manual and make sure they read and understand all operating and service instructions.
- Have the customer sign a completed "Warranty Registration", and mail it.

Date Delivered \_\_\_\_\_

Dealer's Name \_\_\_\_\_

By \_\_\_\_\_

Signature of Original Buyer \_\_\_\_\_

Note: Warranty is not valid until warranty card is completed and returned to H&S Mfg. Co., Inc.

**Intentionally Left Blank**



## SAFETY INFORMATION



**BE  
ALERT!**

**YOUR SAFETY  
IS INVOLVED.**

THIS SYMBOL IS USED THROUGHOUT THIS BOOK WHENEVER YOUR PERSONAL SAFETY IS INVOLVED. TAKE TIME TO BE CAREFUL. REMEMBER: THE CAREFUL OPERATOR IS THE BEST OPERATOR. MOST ACCIDENTS ARE CAUSED BY HUMAN ERROR. CERTAIN PRECAUTIONS MUST BE OBSERVED TO PREVENT THE POSSIBILITY OF INJURY OR DAMAGE.

**H&S MANUFACTURING CO., INC.**

# SAFETY INFORMATION

## RECOGNIZE SAFETY INFORMATION

This is the safety-alert symbol. When you see this symbol on your machine or in this manual, be alert to the potential for personal injury.

Follow recommended precautions and safe operating practices.



## UNDERSTAND SIGNAL WORDS

A signal word; DANGER, WARNING, or CAUTION - is used with the safety-alert symbol. DANGER identifies the most serious hazards.

Safety signs with signal word DANGER or WARNING are typically near specific hazards.

General precautions are listed on CAUTION safety signs.



**WARNING**



**CAUTION**



## FOLLOW SAFETY INSTRUCTIONS

Carefully read all safety messages in this manual, and all safety signs on your machine. Follow all recommended precautions and safe operating procedures.

Keep signs in good condition. Immediately replace any missing or damaged signs.

## OBSERVE MAXIMUM TRANSPORT SPEED

**The maximum transport speed for this implement is 32 km/h (20 m.p.h.).**

Some tractors are capable of operating at speeds that exceed the maximum transport speed of this implement. Regardless of the maximum speed capability of the tractor being used to tow this implement, do not exceed the implement's maximum transport speed.

Exceeding the implements maximum transport speed can result in:

- \* Loss of control of the tractor/implement combination
- \* Reduced or no ability to stop during braking
- \* Implement tire failure
- \* Damage to the implement structure or its components

Use additional caution and reduce speed when towing under adverse surface conditions, when turning, and when on inclines.

Do not attempt transport if the fully loaded implement weighs more than 1.5 times the weight of the tractor.



# SAFETY INFORMATION

**! WARNING**

## HELP AVOID INJURY

- READ & UNDERSTAND THE OPERATORS MANUAL PROVIDED WITH THIS MACHINE. IF MISPLACED CALL H & S MANUFACTURING AT 715-387-3414 WITH MODEL AND SERIAL NUMBER.
- UNDERSTAND ALL SAFETY WARNINGS AND FUNCTION OF CONTROLS.
- KEEP SAFETY DEVICES IN PLACE AND WORKING.
- KEEP YOURSELF AND OTHERS WELL CLEAR OF MOVING PARTS.
- DISCONNECT ALL POWER BEFORE SERVICING OR CLEANING THIS MACHINE.
- DO NOT EXCEED 20 MPH

72203A



**! DANGER**

**STAY CLEAR OF RAKE WHEN OPENING OR CLOSING.**

**FAILURE TO HEED THIS WARNING MAY RESULT IN PERSONAL INJURY OR DEATH**

**KEEP CLOTHING, YOURSELF AND OTHERS WELL CLEAR.**

11694A



**! WARNING**

**STAY CLEAR OF RAKE WHEN RAISING OR LOWERING RAKE WHEELS.**

**FAILURE TO HEED THIS WARNING MAY RESULT IN PERSONAL INJURY OR DEATH.**

**KEEP CLOTHING, YOURSELF AND OTHERS WELL CLEAR.**

2195



**! WARNING**

**DO NOT GO NEAR LEAKS**

- High pressure oil easily punctures skin causing serious injury, gangrene or death.
- If injured, seek emergency medical help. Immediate surgery is required to remove oil.
- Do not use finger or skin to check for leaks.
- Lower load or relieve hydraulic pressure before loosening fittings.

11599

## TRACTOR:

This operators manual uses the term “Tractor” when identifying the power source.



# WARNING

## TO PREVENT SERIOUS INJURY OR DEATH

BEFORE YOU ATTEMPT TO OPERATE THIS EQUIPMENT, READ AND STUDY THE FOLLOWING INFORMATION. IN ADDITION, MAKE SURE THAT EVERY INDIVIDUAL WHO OPERATES OR WORKS WITH THIS EQUIPMENT, WHETHER FAMILY MEMBER OR EMPLOYEE, IS FAMILIAR WITH THESE SAFETY PRECAUTIONS.

### **DO NOT ALLOW PERSONNEL OTHER THAN THE QUALIFIED OPERATOR NEAR THE MACHINE.**

Stop the tractor engine, remove ignition key, and allow all mechanisms to stop before cleaning, working, or adjusting on machine.

**DO NOT** attempt to perform maintenance or repair with tractor running.

**DO NOT** step up on machine at any time.

**DO NOT** allow minors to operate or be near the machine.

Loose or floppy clothing should not be worn by the operator.

Stay clear of hydraulic lines, they may be under extreme pressure or heat.

Stay clear of rake when opening or closing main rake arm beams, or raising or lowering rake wheels.

For transport, always make sure that the hair pin at the rear of the lift pipes, and the transport lock bars with safety clip pins for main rake beam, are securely locked in place.

To reduce stress on rake arms, lift pipe, springs and spring brackets, reduce oil flow from tractor to lift cylinders whenever possible.

Be sure to raise rake wheels before opening or closing main rake beams.

H&S Manufacturing Co. always takes the operator and their safety into consideration and guards exposed moving parts for their protection. However, some areas cannot be guarded or shielded in order to assure proper operation. In addition, the operators manual and decals on the machine itself warn you of further danger and should be read and observed closely.

**Study The Above Safety Rules**  
**ATTENTION - BE ALERT - YOUR SAFETY IS INVOLVED**

# CAP SCREW TORQUE VALUES

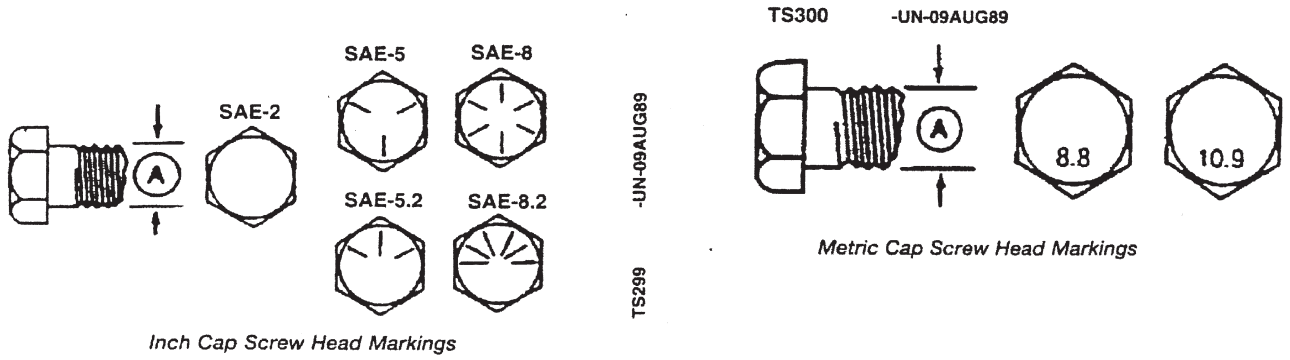

*Inch Cap Screw Head Markings*

*Metric Cap Screw Head Markings*

## INCH CAP SCREW TORQUE VALUES

| Bolt Diameter<br>(A) | Wrench Size | Cap Screw Grade |        |       |        |       |        |
|----------------------|-------------|-----------------|--------|-------|--------|-------|--------|
|                      |             | SAE 2           |        | SAE 5 |        | SAE 8 |        |
|                      |             | N-m             | lb.-ft | N-m   | lb.-ft | N-m   | lb.-ft |
| 1/4"                 | 7/16"       | 7               | (5)    | 11    | (8)    | 16    | (12)   |
| 5/16"                | 1/2"        | 14              | (10)   | 23    | (17)   | 33    | (24)   |
| 3/8"                 | 9/16"       | 24              | (18)   | 41    | (30)   | 54    | (40)   |
| 7/16"                | 5/8"        | 41              | (30)   | 68    | (50)   | 95    | (70)   |
| 1/2"                 | 3/4"        | 61              | (45)   | 102   | (75)   | 142   | (105)  |
| 9/16"                | 13/16"      | 88              | (65)   | 142   | (105)  | 203   | (150)  |
| 5/8"                 | 15/16"      | 122             | (90)   | 197   | (145)  | 278   | (205)  |
| 3/4"                 | 1-1/8"      | 217             | (160)  | 353   | (260)  | 495   | (365)  |
| 7/8"                 | 1-5/16"     | 224             | (165)  | 563   | (415)  | 800   | (590)  |
| 1"                   | 1-1/2"      | 332             | (245)  | 848   | (625)  | 1193  | (880)  |
| 1-1/4"               | 1-7/8"      | 665             | (490)  | 1492  | (1100) | 2393  | (1765) |

## METRIC CAP SCREW TORQUE VALUES

| Bolt Diameter<br>(A) | Wrench Size | Markings on Cap Screw Heads |        |      |        |
|----------------------|-------------|-----------------------------|--------|------|--------|
|                      |             | 8.8                         |        | 10.9 |        |
|                      |             | N-m                         | lb.-ft | N-m  | lb.-ft |
| 5 mm                 | 8 mm        | 6                           | (4.5)  | 9    | (6.5)  |
| 6 mm                 | 10 mm       | 10                          | (7.5)  | 15   | (11)   |
| 8 mm                 | 13 mm       | 25                          | (18)   | 35   | (26)   |
| 10 mm                | 16 mm       | 50                          | (37)   | 75   | (55)   |
| 12 mm                | 18 mm       | 85                          | (63)   | 130  | (97)   |
| 16 mm                | 24 mm       | 215                         | (159)  | 315  | (232)  |
| 20 mm                | 30 mm       | 435                         | (321)  | 620  | (457)  |
| 24 mm                | 36 mm       | 750                         | (553)  | 1070 | (789)  |
| 30 mm                | 46 mm       | 1495                        | (1103) | 2130 | (1571) |



**CAUTION:** Use only metric tools on metric hardware. Other tools may not fit properly. They may slip and cause injury.

DO NOT use these values if a different torque value tightening procedure is listed for a specific application. Torque values listed are for general use only. Check tightness of cap screws periodically.

Shear bolts are designed to fail under predetermined loads. Always replace shear bolts with identical grade. Fasteners should be replaced with the same or higher grade. If higher grade fasteners are used, these should only be tightened to the strength of the original.

Make sure fastener threads are clean and you properly start thread engagement. This will prevent them from failing when tightening.

Tighten plastic insert or crimped steel-type lock nuts to approximately 50 percent of amount shown in chart. Tighten toothed or serrated-type lock nuts to full torque value.

## **SET-UP & ASSEMBLY**

**NOTE:** Determine right or left side of the wheel rake by viewing it from the rear. If instructions or parts lists call for hardened bolts, refer to bolt torque chart.

1. Assemble the rake or check the rake for proper assembly and adjustment. Make sure that all bolts are tightened.
2. Attach the wheels with tires, using the lug nuts furnished and torque the mounting hardware to 95 ft./lbs. of torque. Check wheel bolts periodically thereafter.
3. Check tires and inflate to the recommended pressure. (6.70 x 15 to 36 pounds)
4. Lubricate the rake completely (See Lubrication Chapter in This Manual).
5. Tooth bolts must be torqued to 40 ft./lbs. to help prevent excessive tooth breakage.  
**Re-torque rake tooth bolts after the first 100 acres. Check periodically thereafter.**

# TRANSPORTING

## TRANSPORT LOCKS

### Rake Beam Locks

Transport locks are mounted to the front of the pole. (A) Shows the rake locked into transport position. (B) Shows the transport locks in the convenient storage position, to be used when in the raking mode.

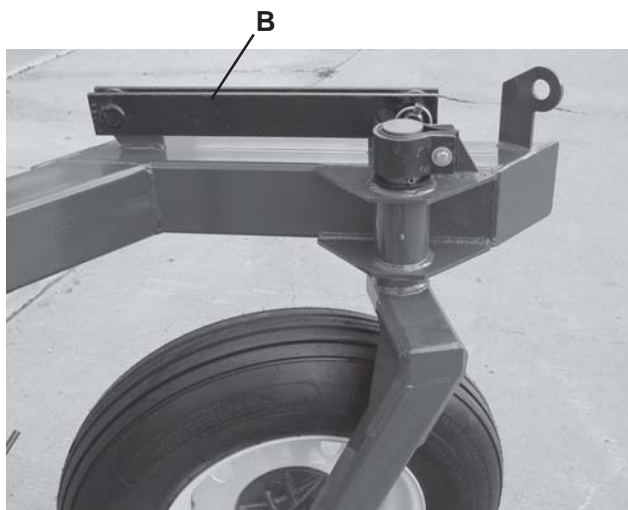
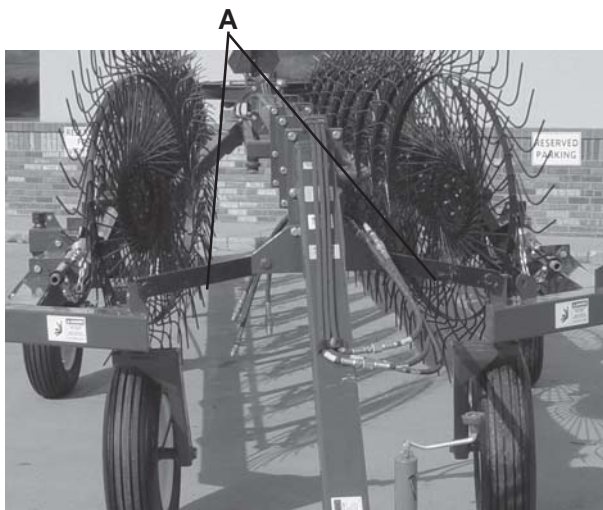

### Rake Wheel Locks

Located at the rear of the lift pipe, is a hair pin which is used to secure the rake wheels in the up position for transport (C). When in the down, or raking position, place the locking hair pin in the convenient storage position as shown (D).

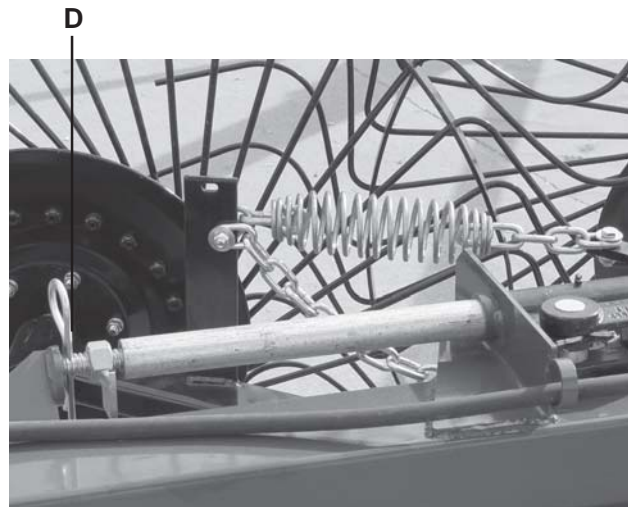
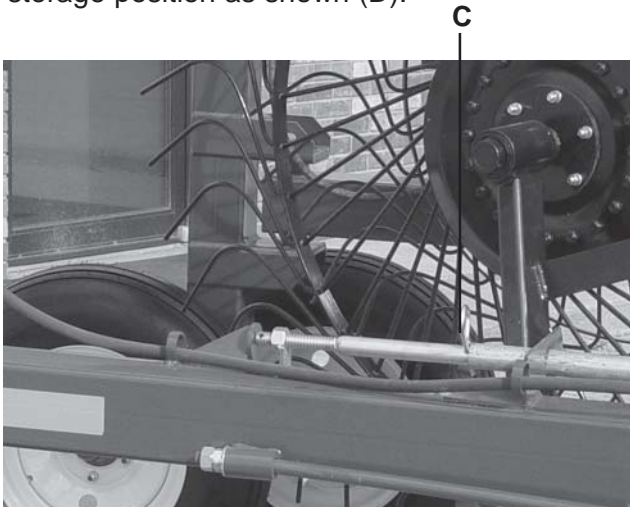

## TOWING ON HIGHWAY

Follow state and local regulations when towing farm equipment on public highways. Never tow the rake on a public highway at a speed greater than 20 m.p.h. (32 kph).

## REFLECTORS

Red and Amber reflective safety decals are on the rake for safety. Refer to the Decal Placement Chapter for location.

## PREPARING FOR OPERATION

1. Adjust the tractor hitch (13 to 17 inches above ground) and attach rake to tractor with a **hitch pin with a safety locking device**.

2. There are ten different positions to adjust the hitch on your new Hi-Capacity Rake. Hitch should be adjusted so main frame of the rake is level or parallel to the ground.



3. Remove weight from lift jack. Remove jack from pipe and place on convenient storage mount located on the front top of pole.

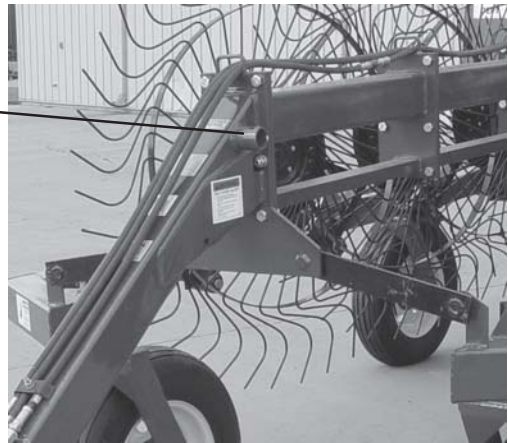

4. Connect hydraulic hose for raising and lowering rake wheels from rake to a double acting valve on the tractor.

5. Connect hydraulic hoses for opening and closing the rake to a double acting valve on the tractor.

6. Connect 7-pin electrical connector to tractor (If equipped with optional lighting).



# OPERATION & ADJUSTMENTS

## EMERGENCY SHUTDOWN

Stop the tractor engine, remove ignition key, and allow all mechanisms to stop before cleaning or working on the machine.

## RAKING WIDTH

Raking width is determined by setting the spring loaded stop, located above the rear pole section as shown.

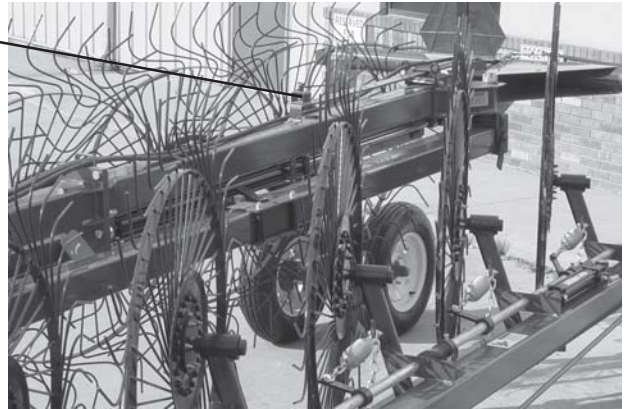
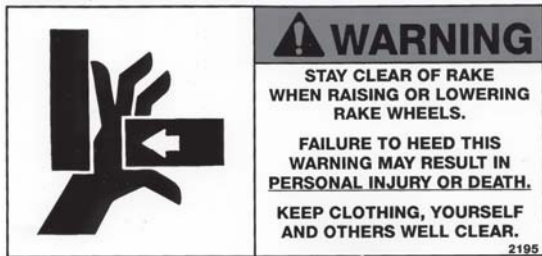

## GROUND PRESSURE

Rake wheel to ground pressure is adjusted by turning the threaded rod while the rake wheels are in the raised position. This allows the tab nut to stay stationary while the threaded rod rotates, thus decreasing pressure, or increasing pressure. The further forward that the nut is on the threaded rod, the lesser the amount of rake wheel ground pressure.

The further back that the nut is on the threaded rod, the greater the amount of rake wheel ground pressure.

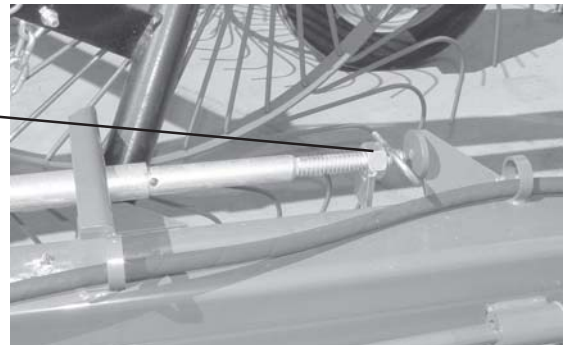

## WINDROW WIDTH

Windrow width is adjustable from 38" to 58". Adjustment is made by turning the crank, located on the left of the rear of the rake as shown.



# OPERATION & ADJUSTMENTS

## GAUGE WHEELS

Outboard gauge wheels are located on the forward section of each rake beam. These gauge wheels support the rake beams to allow the rake wheels to better follow the contour of the ground. Located on the gauge wheel pivot spindle is an adjustable brake assembly. Adjust brake by tightening bolt. The brake should have enough tension to prevent zig-zag motion, but still allow the wheel to pivot when making corners.



Adjustable  
Brake  
Assembly

## ONE SIDED RAKING

Raking with one side only can be accomplished by first locking the left side of the rake into transport position utilizing both the front and rear transport locks. Next, remove Pin (E) attaching front linkage arm to main linkage arm, and place in storage hole (F). Also remove Pin (G) at the rear of the main linkage arm and place in the storage position (H) located in hitch attachment gusset at the rear of the rake (Lowering of rake wheels will aid in removal/installation of pins. Be sure rear transport lock is in transport position prior to raking with one side.) The right side can now be opened, and used to rake.

**NOTE:** Only the right side of your Hi-Capacity Rake can be used in this manner.

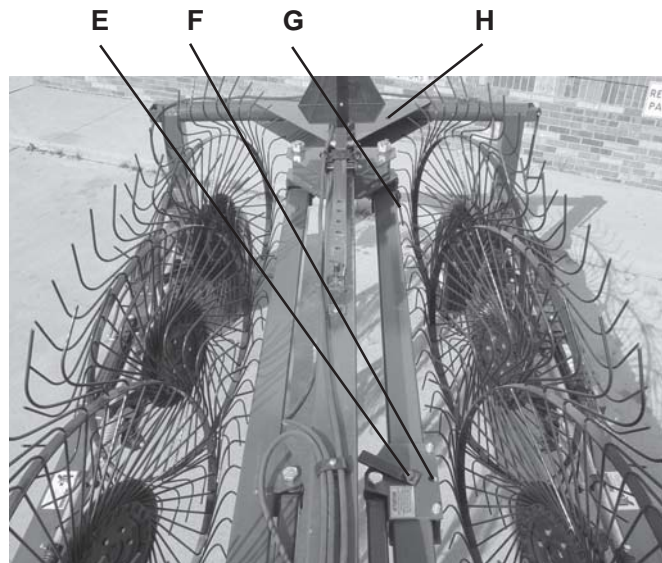

# OPTIONAL EQUIPMENT

## OPTIONAL CENTER KICKER WHEEL

There are two optional center kicker wheel assemblies available for the 5114/5116 Hi-Capacity Rakes. If the hay is laying out flat, these extra wheels allow you to raise the hay laying in the center of the rake out of the stubble for faster drying, and easier pick-up. A separate cylinder controls the kicker wheel assembly. It raises and lowers with the rake wheels.

### 2-Wheel Center Kicker Wheel

To engage center kicker wheels, hydraulically open rake to desired raking width. Remove Locking Pin (C), swivel kicker wheel assembly to the desired raking angle. Re-insert the locking pin. Next, remove Locking Pin (A) from transport lock position, and insert into convenient Storage Position (B). Lower rake wheels to begin raking.

To return to transport position, PRIOR TO CLOSING RAKE, raise rake wheels. (This will also raise the center kicker wheel assembly). Remove Locking Pin (C), Swivel kicker wheel assembly so that it is in line with the hitch pole. Re-insert Pin (C). Remove locking pin from Storage Position (B), and insert to lock the unit into the up, or Transport Position (A). Rake beams may now be closed for transport.

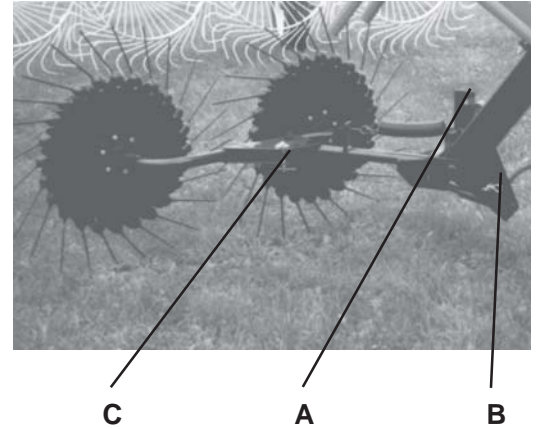

### 3-Wheel Center Kicker Wheel

To engage center kicker wheels, hydraulically open rake to desired raking width. Remove Locking Pin (A), swivel kicker wheel assembly to the desired raking angle. Re-insert the Locking Pin. Next, remove Locking Pin (B) from the oscillation lock position, and insert into the convenient storage position (C). Next remove the transport lock pin (D) and insert into the convenient storage position (E). Lower rake wheels to begin raking.

To return to transport position, PRIOR TO CLOSING RAKE, raise rake wheels. (This will also raise the center kicker wheel assembly). Remove Locking Pin (A), Swivel kicker wheel assembly so that it is in line with the hitch pole. Re-insert Pin (A). Remove locking pin from Storage Position (C), and re-insert pin (B) into the oscillation lock position. Next remove lock pin (D) from storage position (E) and insert to lock the unit into the up, or Transport Position. Rake beams may now be closed for transport.

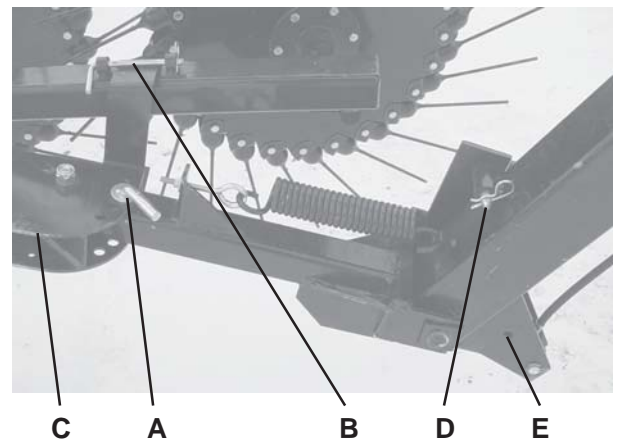

# LUBRICATION GUIDE

## GREASE FITTINGS

There are numerous grease fittings on the 5114 and 5116 Hi-Capacity Rakes. If equipped with a center kicker wheel, there will be one more on the pivot point. If lubricated properly and often enough, it will prolong the life of your Hi-Capacity Rake. Grease daily during normal use and **before and after storage and after power washing**. Use a good grade of high quality grease. Make sure that grease comes out around the shaft on sleeve type bearings. Wipe off excessive grease to prevent accumulation of chaff or grit around the bearing.

## LOCATION

Listed and shown are the description of location and number of grease fittings.

- A. (2) Top Opening Arm Front Pivot
- B. (4) One on Each Gauge Wheel
- C. (2) One on Each Lift Cylinder Mounting Bracket
- D. (2) One on Each Rake Beam Pivot
- E. (6) Top Rear Windrow Width Adjustment
- F. (5) Top Opening Arm Rear Pivot
- G. (1) Center Kicker Wheel Pivots (If Equipped)
- (8) One on Each Transport Wheel Hub

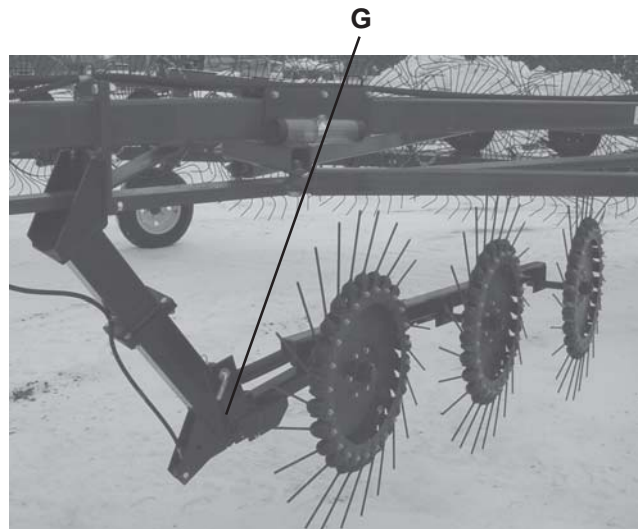
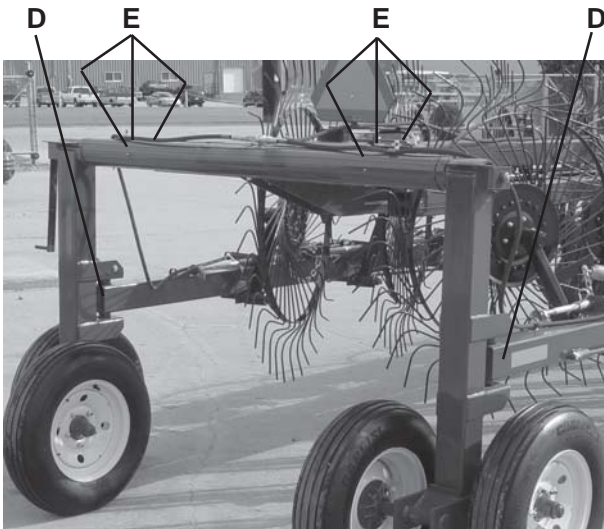
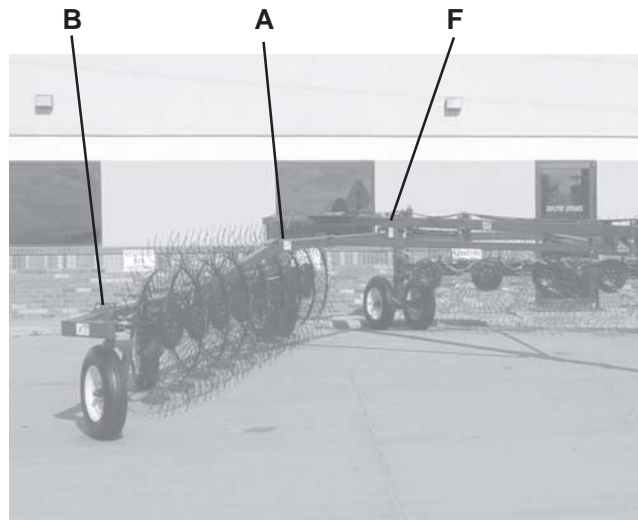
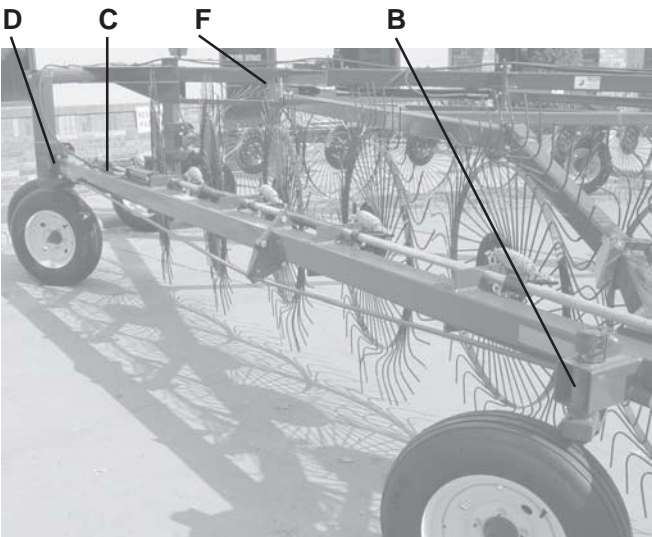

# DECAL LOCATION

Your Rake was manufactured with operator safety in mind. Located on the Hi-Capacity Rake are various decals to aid in operation, and warn of danger or caution areas. Pay close attention to all the decals.



**DO NOT REMOVE ANY OF THESE DECALS. IF DECALS ARE LOST, DAMAGED, OR IF THE HI-CAPACITY RAKE IS REPAINTED, REPLACE DECALS. REMEMBER: DECALS ARE FOR YOUR PROTECTION AND INFORMATION.**

Listed below are the decals on your H&S Hi-Capacity Rake. These decals may be ordered individually by part number or by ordering complete set.

| <u>PART</u> | <u>QUANTITY</u> | <u>DESCRIPTION</u>                                   |
|-------------|-----------------|--|
| 311         | 1               | Patent Numbers                                       |
| 2195        | 4               | WARNING - Stay Clear of Rake                         |
| 71273       | 2               | Model Decal 5114                                     |
| 71275       | 2               | H&S Hi-Capacity Rake Decal Left & Rear 5114          |
| 71277       | 1               | H&S Hi-Capacity Rake Decal Right 5114                |
| 093020      | 19              | Grease Zerk  |
| 11501B      | 2               | ATTENTION: Remove Both Pins                          |
| 11599       | 3               | WARNING - Do Not Go Near Leaks                       |
| 11694A      | 8               | DANGER - Stay Clear of Rake                          |
| 12197A      | 1               | Attention: Raise Rake Wheels                         |
| 54033       | 1               | Made in the USA                                      |
| 71188B      | 1               | Jack Storage Position                                |
| 72203A      | 1               | WARNING - Help Avoid Injury                          |
| BFR723      | 1               | SMV Sign Kit   |
| DCAMB       | 4               | Amber Reflector - 2" x 9" (2 On Each Main Rake Beam) |
| DCAMB1      | 1               | Amber Reflector - 3-1/4" x 5-5/8"                    |
| DCRED       | 2               | Red Reflectors                                       |

# DECAL LOCATION

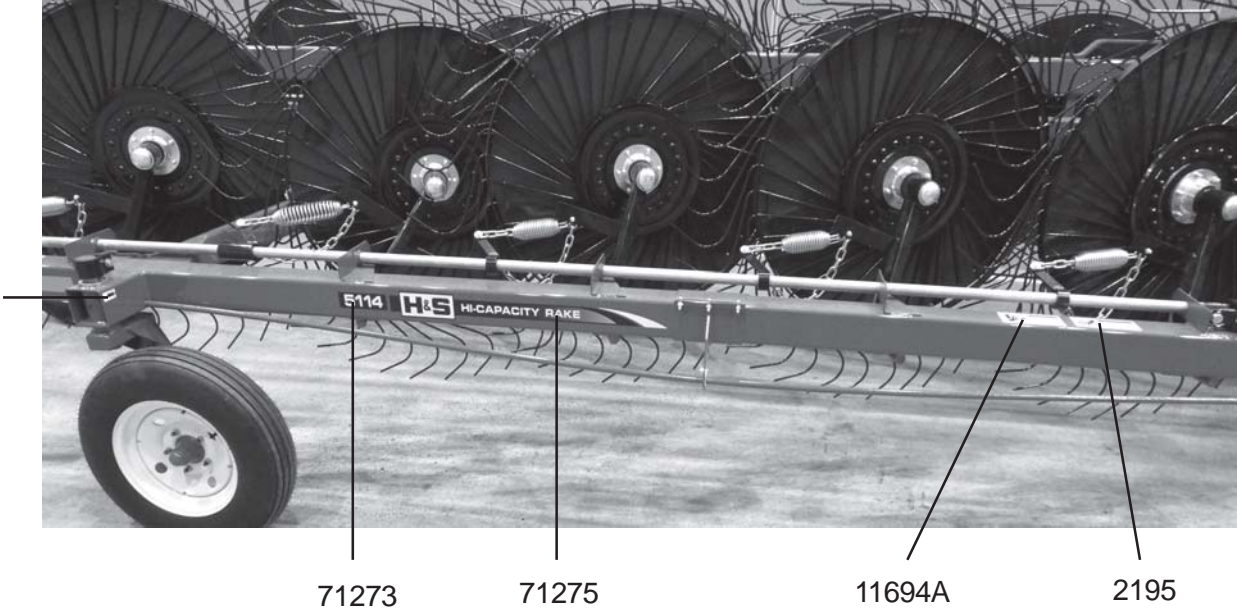
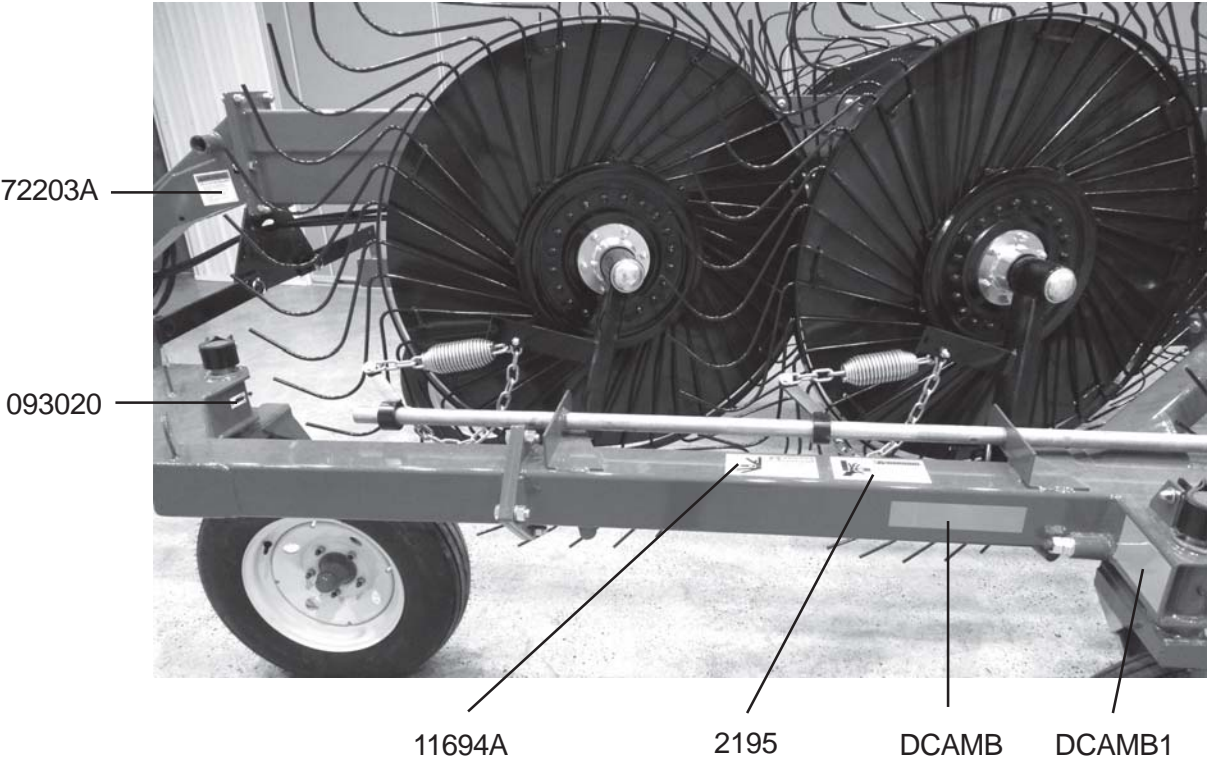

# DECAL LOCATION

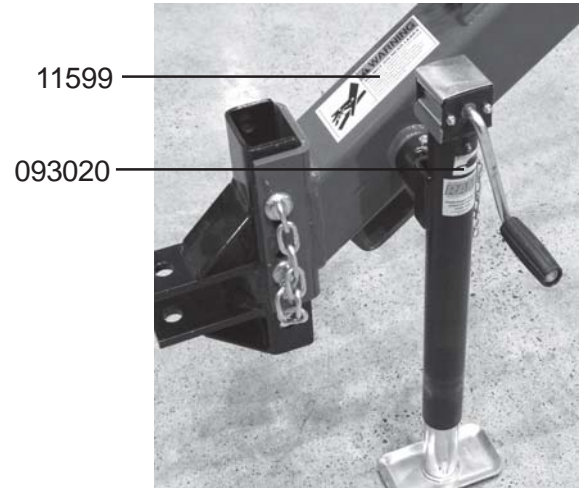
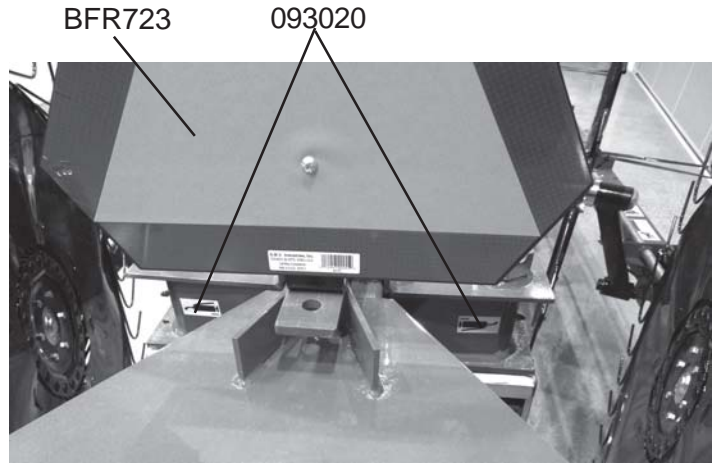
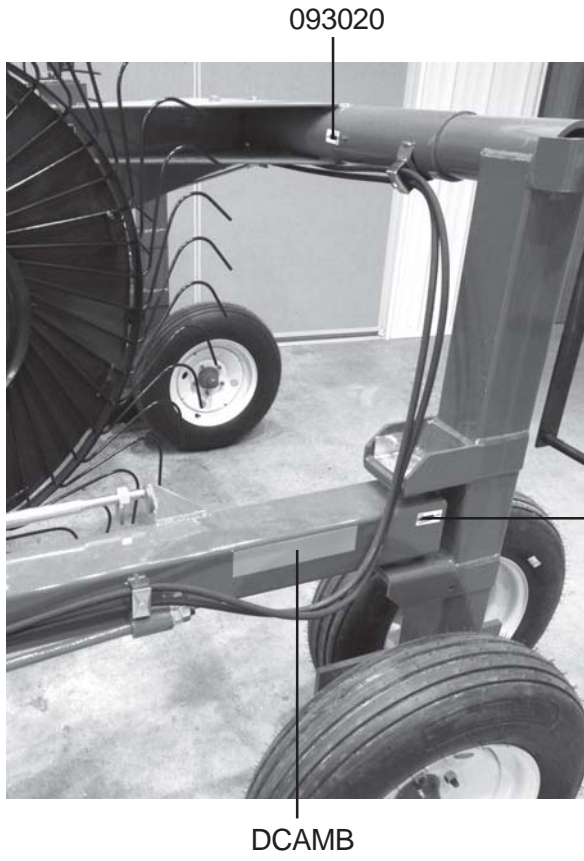

# DECAL LOCATION



093020

093020

DCAMB

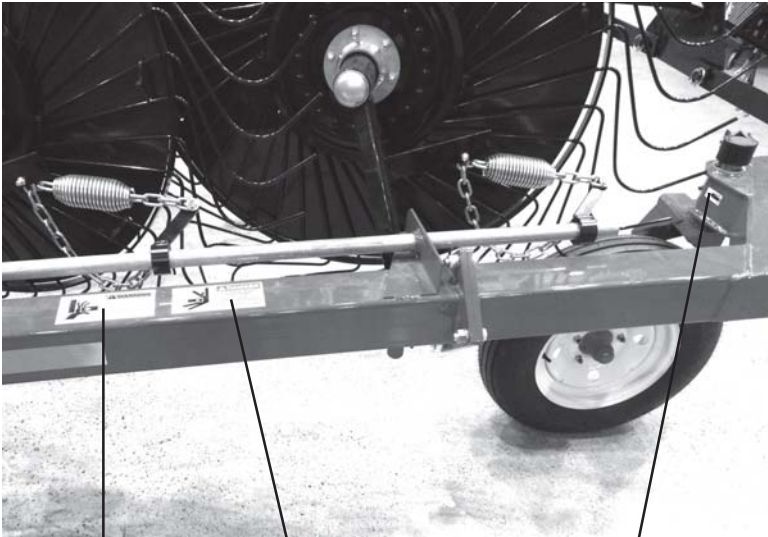

2195

11694A

093020

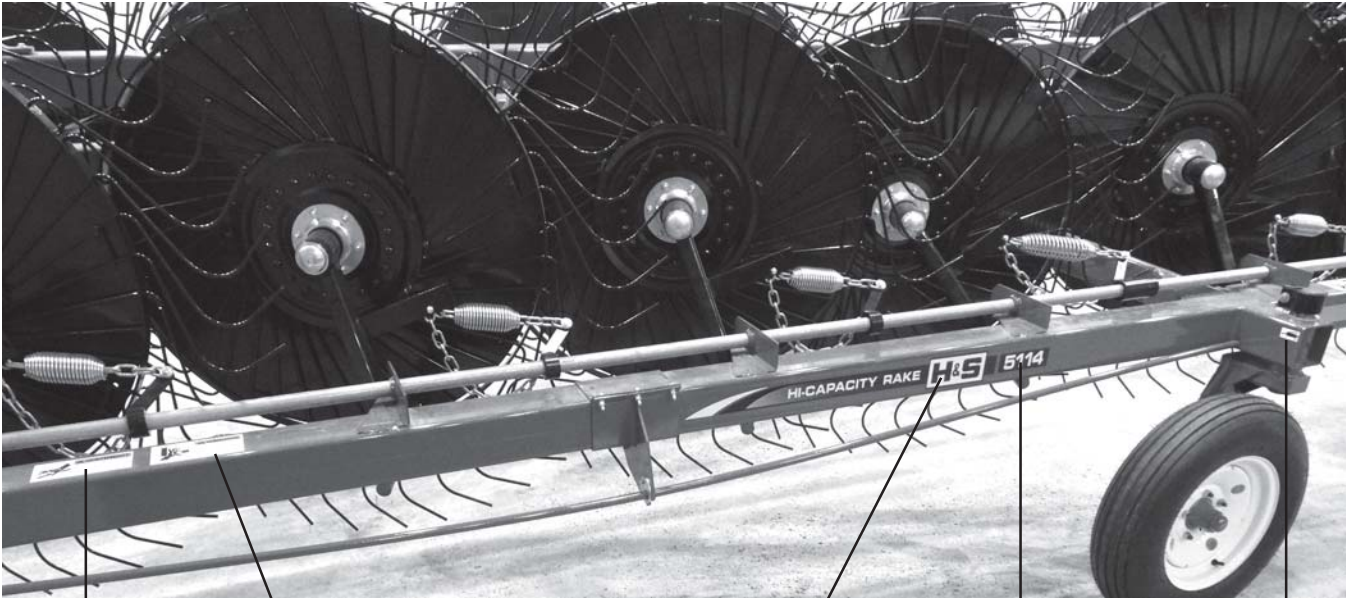

11599

2195

71277

71273

093020



# DECAL LOCATION

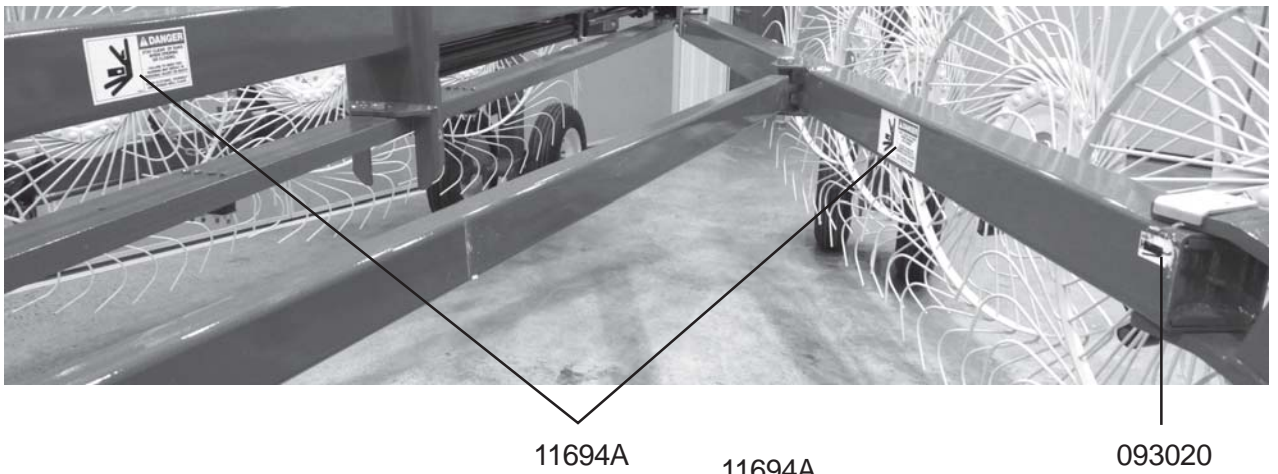
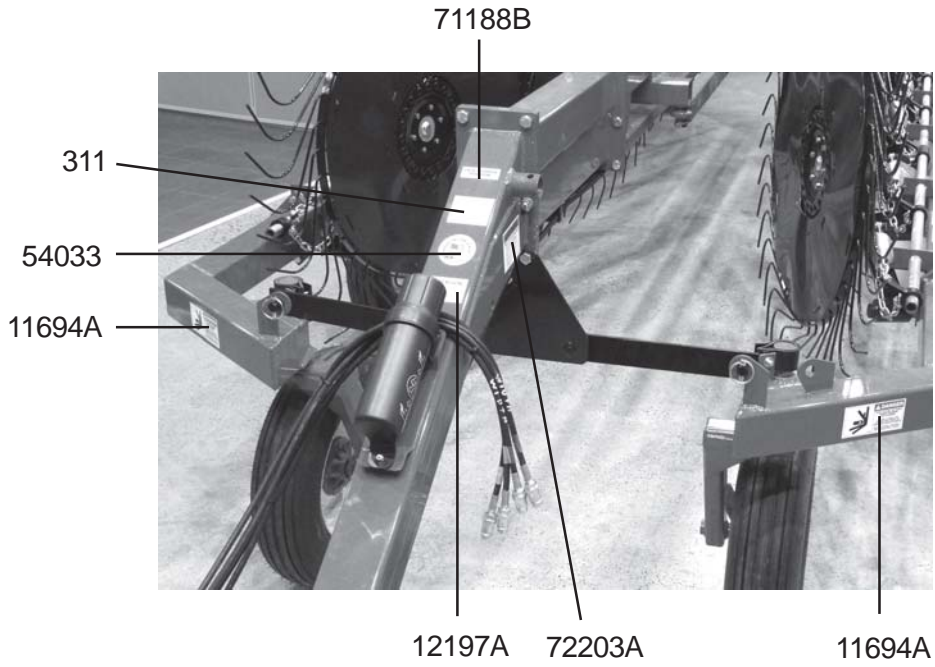

# TROUBLE SHOOTING



**WARNING:**

**MAKE SURE THAT THE TRACTOR IS SHUT OFF AND THE RAKE CAN NOT MOVE BEFORE SERVICING THE 1460-1660 HI-CAPACITY RAKE. MAINTENANCE AND REPAIR SERVICE WORK TO BE PERFORMED BY A QUALIFIED SERVICE PERSON ONLY.**

| <u>TROUBLE</u>             | <u>POSSIBLE CAUSE</u>   | <u>POSSIBLE REMEDY</u>  |
|----------------------------|---|---|
| Rake Will Not Open         | Rake Locked In Transport                                      | Remove Transport Locks And Return To Storage Position   |
|                            | Hydraulic Couplers Not Coupled To Tractor Properly            | Couple Hydraulic Hoses To Tractor   |
|                            | Hydraulic Hoses Mixed Up With Rake Wheel Lift Hose            | Sort Hoses Correctly And Re-couple To Tractor   |
|                            | Tractor Hydraulics Do Not Have Sufficient Pressure            | Tractor Should Have At Least 1500 PSI To Operate Rake<br>NOTE: Always Drive Forward Slowly And Open Rake At The Same Time |
| Rake Will Not Close        | Tractor Hydraulics Do Not Have Sufficient Pressure            | Tractor Should Have At Least 1500 PSI To Operate Rake<br>NOTE: Always Drive Forward Slowly And Open Rake At The Same Time |
| Rake Wheels Will Not Lower | Rake Wheels Locked In Transport                               | Remove Hair Pin From Adjuster, Place In Storage Position  |
|                            | Lift Pipe Binding   | Check Lift Pipe Make Sure It Is Free Moving   |
|                            | Tractor Hydraulics Not Able To Operate Single Acting Cylinder | Consult Your Tractor Dealer on How This Can Be Accomplished   |





## SPECIFICATIONS

|                               |                    |           |
|-------------------------------|--------------------|-----------|
| Number of Wheels.....         | 14.....            | 16        |
| Wheel Diameter.....           | 60".....           | 60"       |
| Teeth per Wheel.....          | 40.....            | 40        |
| Tooth Diameter.....           | 7mm.....           | 7mm       |
| Transport Width.....          | 8'8".....          | 8'8"      |
| Transport Length.....         | 27'3".....         | 30'3"     |
| Maximum Raking Width.....     | 28'.....           | 32'       |
| Windrow Width Adjustment..... | 38"-58".....       | 38"-58"   |
| Weight.....                   | 4200 lbs.....      | 4600 lbs. |
| Rake Wheel Hubs.....          | Ball Bearings..... |           |
| Hitch Jack.....               | Standard.....      |           |
| Tail Lights.....              | Optional.....      |           |
| Center Kicker Wheel.....      | Optional.....      |           |
| Tires.....                    | 8 - 6.70 x 15..... |           |

**H&S MFG. CO.**

products approved

for the

**FEMA**

**SEAL OF QUALITY**

