



HPV4255

MANURE SPREADER

PARTS BOOK

Part #91692

HSMFG102522

Rev. #03

Starting Ser. #322VP55001

STRONG HERITAGE - STRONG PEOPLE - STRONGER FUTURE



TABLE OF CONTENTS

FIGURE #	CONTENTS	PAGE #
*	INSTRUCTIONS FOR ORDER PARTS	1
1	HITCH & COMPONENTS	2-3
2	FLOOR & SIDE COMPONENTS	4-5
3	PTO SHIELD & COMPONENTS	6-7
4	PUSHER & COMPONENTS	8-9
5	PUSHER EXTENSION & COMPONENTS	10-11
6	PUSHER SPACERS & COMPONENTS	12-13
7	GEARBOX DRIVE & COMPONENTS	14-15-
8	HYDRAULICS	16-19
9	TANDEM AXLE & WHEEL COMPONENTS	20-21
10	ENDGATE & COMPONENTS	22-23
11	BEATER PANELS & COMPONENTS	24-25
12	BEATERS & COMPONENTS	26-27
13	LIGHTS	28-29
14	BEATER GEARBOX ASSEMBLY	30-31
15	OPTIONAL FLOW CONTROL (HPOVSC)	32-33
16	OPTIONAL VARIABLE SPEED CONTROL (HPOVSEC)	34-35
17	OPTIONAL SCREEN EXTENSION (HPOFASE)	36-37
18	HPO1034CV PTO	38-39
19	HPO1038CV PTO	40-41
20	1000 RPM PTO	42-43
21	OPTIONAL TWP600S (HPOHTA550)	44-45
*	PARTS NOTES	46



INSTRUCTIONS FOR ORDERING PARTS

All service parts should be ordered through your authorized H&S dealer. Your Dealership will be able to give you faster service if you will provide them with the following:

1. All references to left or right apply to the machine as viewed from the rear.
2. Parts should not be ordered from illustration only. Please order complete part number.
3. If your dealer has to order parts - give shipping instructions:

VIA truck - large pieces (please specify local truck lines)

VIA United Parcel Service (include full address)

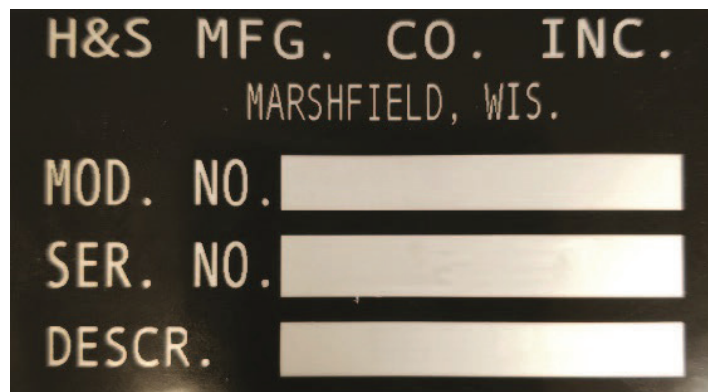

MODEL & SERIAL NUMBER LOCATED ON
FRONT, LEFT SIDE OF PTO BEARING SUPPORT MOUNT

PLEASE RECORD NUMBERS FOR YOUR UNIT FOR QUICK REFERENCE

H&S IS CONTINUALLY STRIVING TO IMPROVE ITS PRODUCTS

We must, therefore, reserve the right to make improvements or changes whenever it becomes practical to do so, without incurring any obligation to make changes or additions to the equipment previously sold.





FIGURE 1
HITCH & COMPONENTS

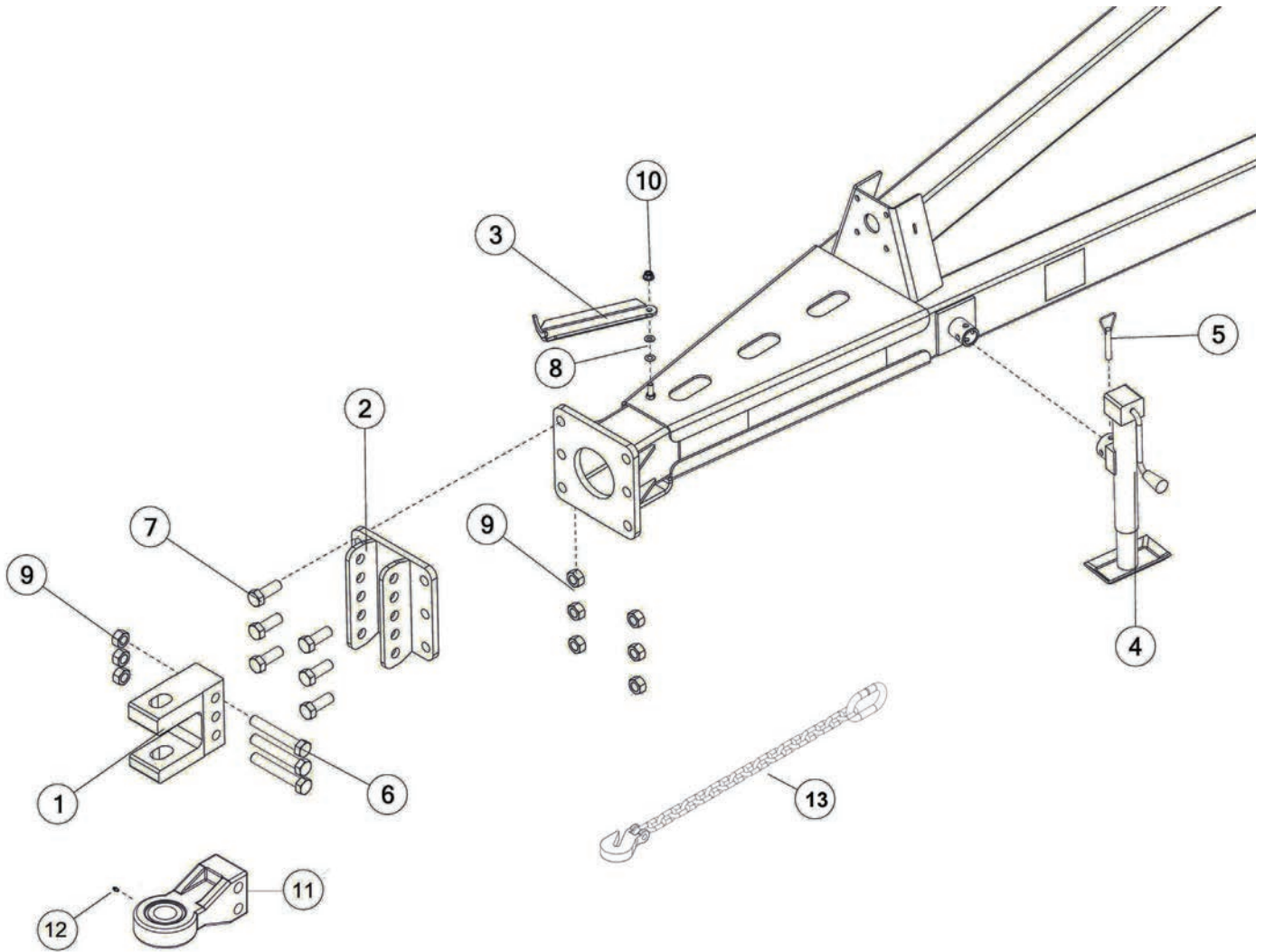



FIGURE 1 HITCH & COMPONENTS

REF #	PART #	DESCRIPTION	QTY
1	56310	HEAVY CLEVIS OPTION	1
2	89538	HITCH MOUNT	1
3	42N2	PTO HOLDER	1
4	TS306	SIDE WIND JACK, 7000#	1
5	12N117	PIN, 0.56, 5.19, JACK	1
6	YBHH32028	BOLT HEX, 1-8 X 6-1/2 G8 ZY	3
7	YBHH32006	BOLT HEX, 1-8 X 2-3/4 G5	6
8	42N3	SPRING	2
9	YN TL32005	NUT HEX, 1-8 LKTL C ZC	9
10	YNFG16003	NUT FLANGE, 1/2 GF	1
11	58290	ARTICULATING HITCH OPTION	1
12	G89	STRAIGHT ZERK, 1/4	1
13	SC40500	SAFETY CHAIN, 40,500 LB RATING, OPTIONAL	1





FIGURE 2 FLOOR & SIDE COMPONENTS

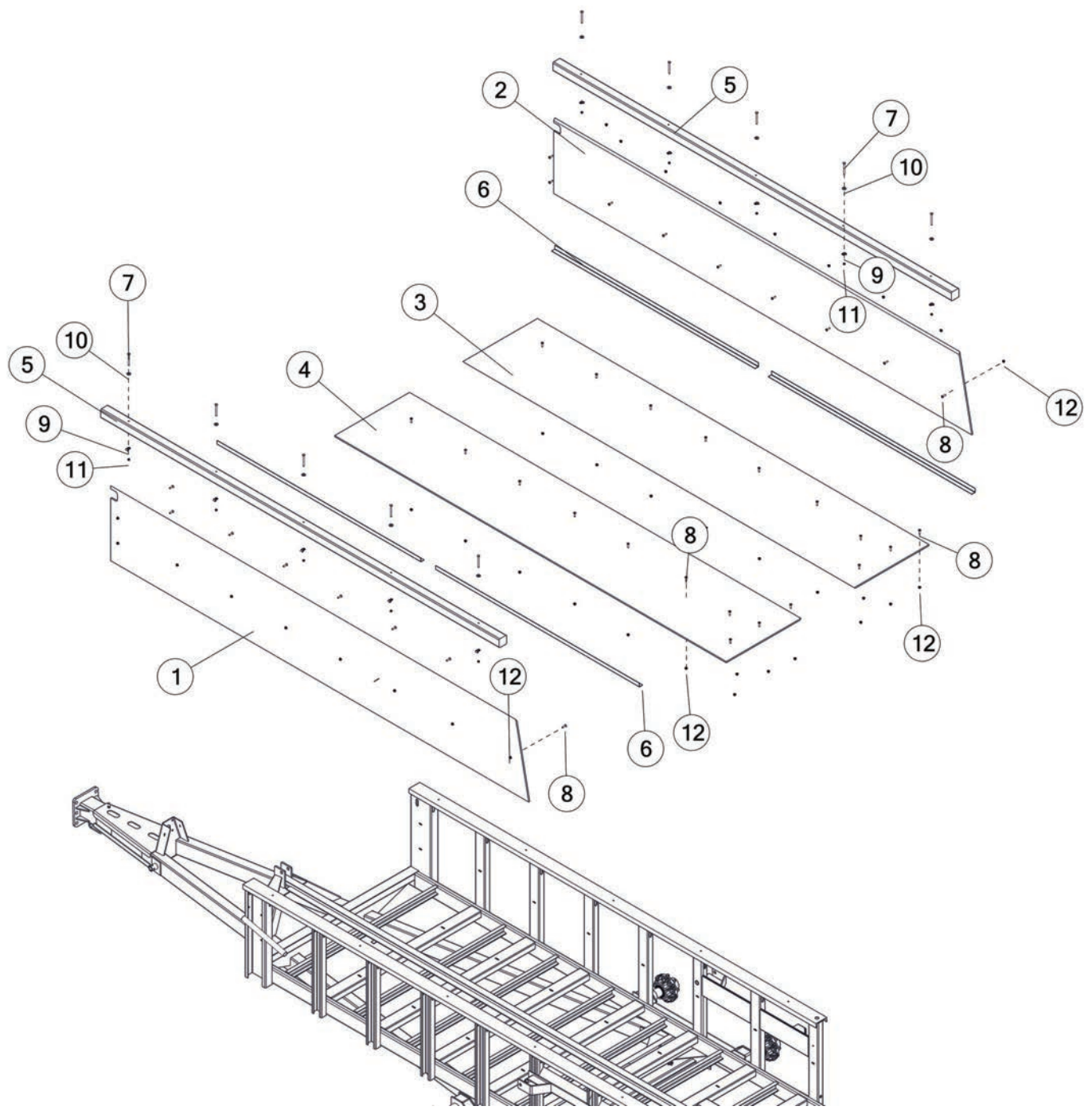



FIGURE 3 PTO SHIELD & COMPONENTS

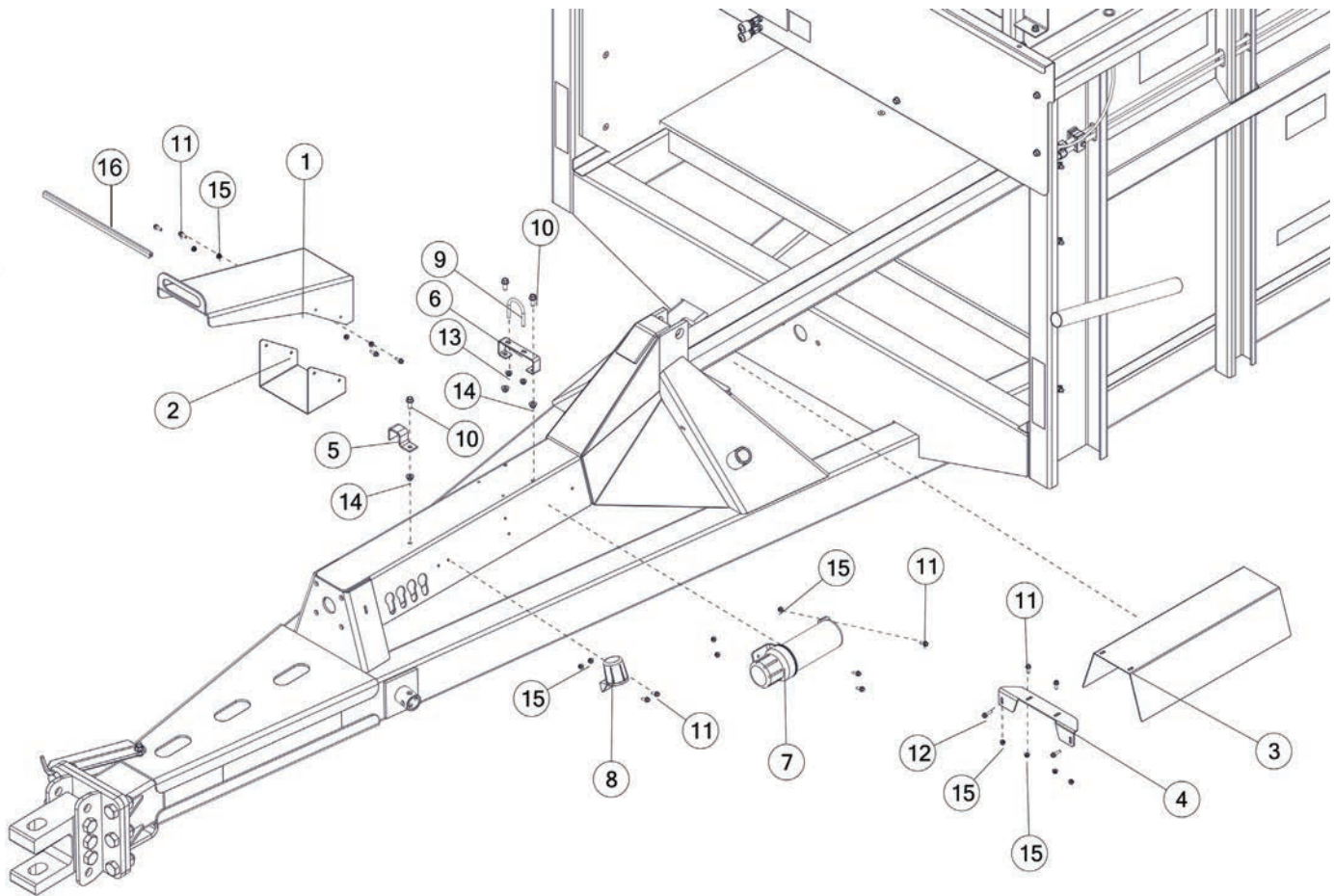



FIGURE 3

PTO SHIELD & COMPONENTS

REF #	PART #	DESCRIPTION	QTY
1	90164B	PTO SHIELD W/DECALS	1
2	90168	LOWER PTO SHIELD	1
3	89564	INPUT SHIELD	1
4	88927	INPUT SHIELD ANGLE	1
5	HE14	SMALL PIPE BRACKET	1
6	89639	HOSE HOLDER	1
7	S522	MANUAL HOLDER	1
8	CHM38	PLUG STORAGE	1
9	YBPU10007	PIPE U BOLT, 5/16 X 1-1/2	1
10	YBFB12003	BOLT FLANGE, 3/8 X 1 G5	3
11	YBFB08075	BOLT FLANGE, 1/4 X 3/4 G5	11
12	YBFB08100	BOLT FLANGE, 1/4 X 1 G5	12
13	YNFG10005	NUT FLANGE, 5/16 GF	2
14	YNFG12006	NUT FLANGE, 3/8 GF	3
15	YNFG08010	NUT FLANGE, 1/4 GF	13
16	96213	EDGE TRIM, 1/4 X 14	1





FIGURE 4 PUSHER COMPONENTS

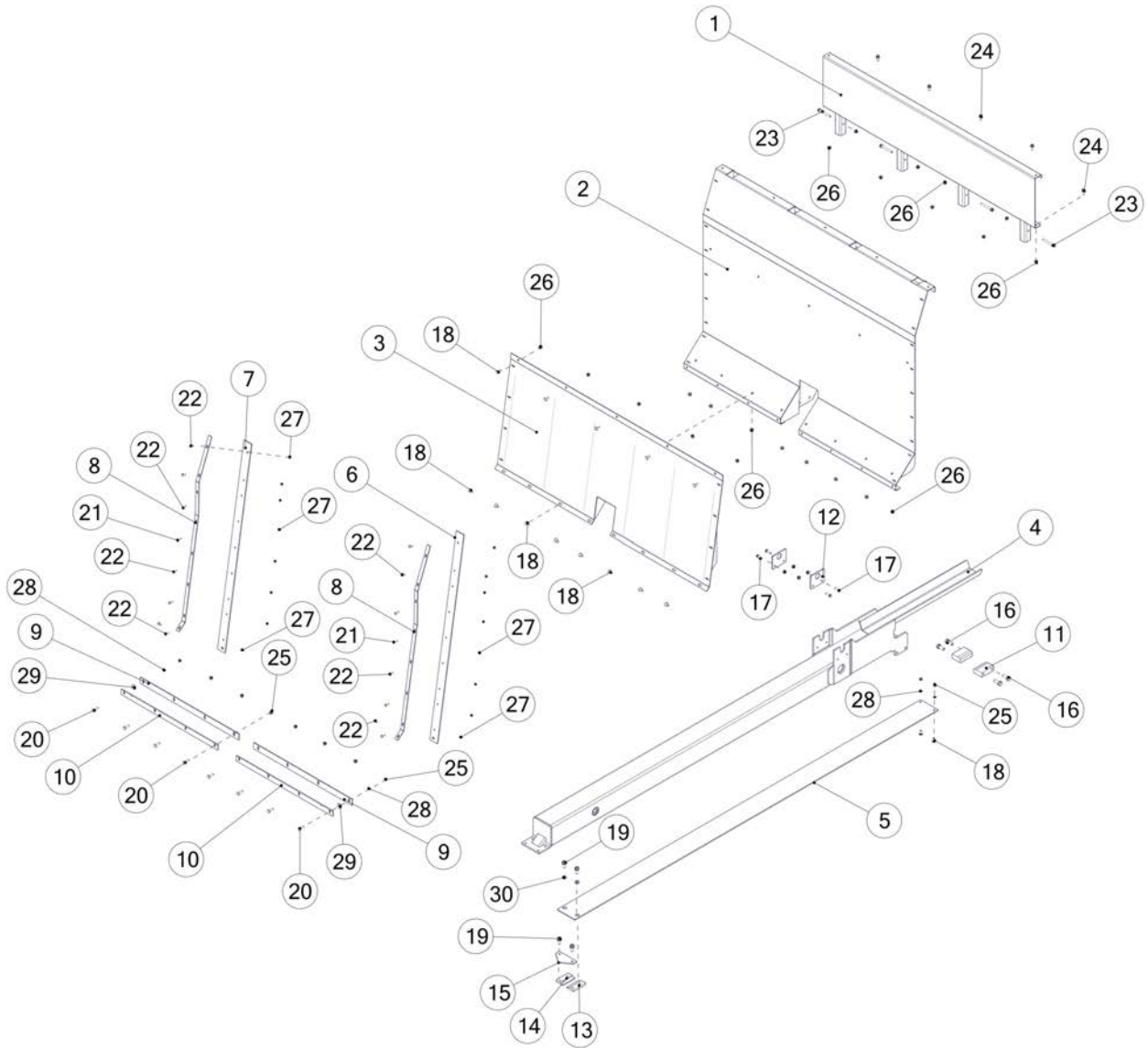



FIGURE 4 PUSHER COMPONENTS

REF #	PART #	DESCRIPTION	QTY
1	90065	PUSHER EXTENSION	1
2	90095	PUSHER FRAME	1
3	HGV113	FLAT PUSHER FACE	1
4	55N44	MOVEABLE FLOOR	1
5	55N85	PUSHER TUBING SLIDE	1
6	55N28	PUSHER RUBBER RH	1
7	55N27	PUSHER RUBBER LH	1
8	HGV114	FLAT PUSHER SEAL STRAP	2
9	55N83	PUSHER BOTTOM RUBBER	2
10	55N81	PUSHER WIPER	2
11	55N46	PUSHER FRONT GUIDE	2
12	55N47	CYLINDER RETAINER	2
13	55N48	END CAP CLAMP RH	1
14	55N49	END CAP CLAMP LH	1
15	55N86	SCRAPER	1
16	YBHH20010	BOLT HEX, 5/8-11 X 1-1/2 G5	4
17	YBHH12035	BOLT HEX, 3/8-16 X 1-1/4 G5	4
18	YBCR12010	BOLT CARRIAGE, 3/8-16 X 1 G5 ZC	15
19	YBFB16125	BOLT FLANGE, 1/2 X 1-1/4 G5	4
20	YBCR12015	BOLT CARRIAGE, 3/8-16 X 1-1/2 G5 ZC	8
21	YBCR08015	BOLT CARRIAGE, 1/4-20 X 1-1/4 G5 ZC	2
22	YBCR08005	BOLT CARRIAGE, 1/4-20 X 1 G5 ZC	14
23	YBFB12350	BOLT FLANGE, 3/8 X 3-1/2 G5	4
24	YBFB12003	BOLT FLANGE, 3/8 X 1 G5	5
25	YNHX12005	NUT HEX, 3/8-16, NA A ZC	4
26	YNFG12006	NUT FLANGE, 3/8 GF	28
27	YNFG08010	NUT FLANGE, 1/4 GF	16
28	YWLO12005	WASHER, LOCK, 3/8	4
29	YWFL14005	WASHER, FLAT, 7/16 ZC	2
30	42N150	POLY SPACER	2





FIGURE 5 PUSHER EXTENSION & COMPONENTS

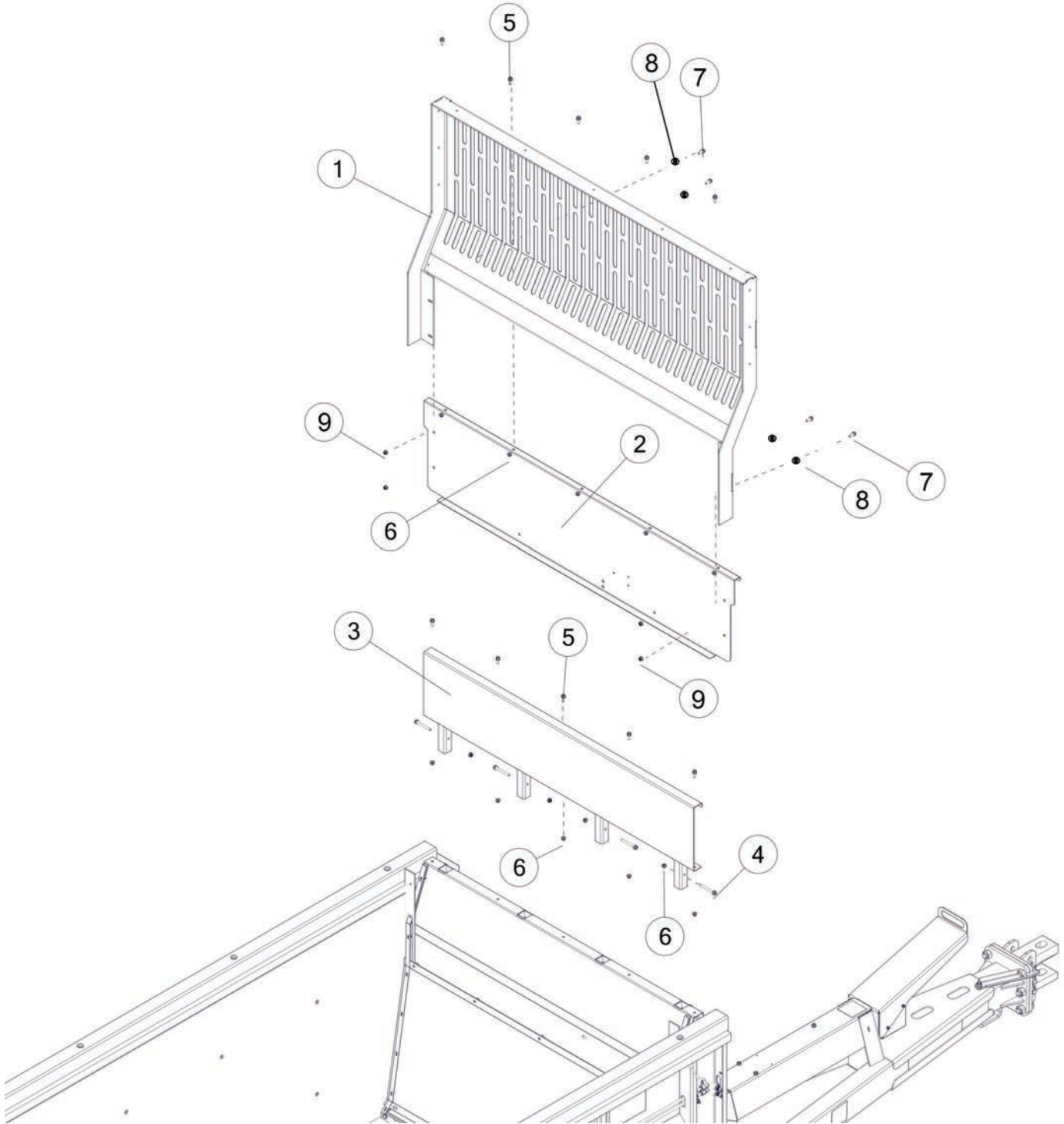
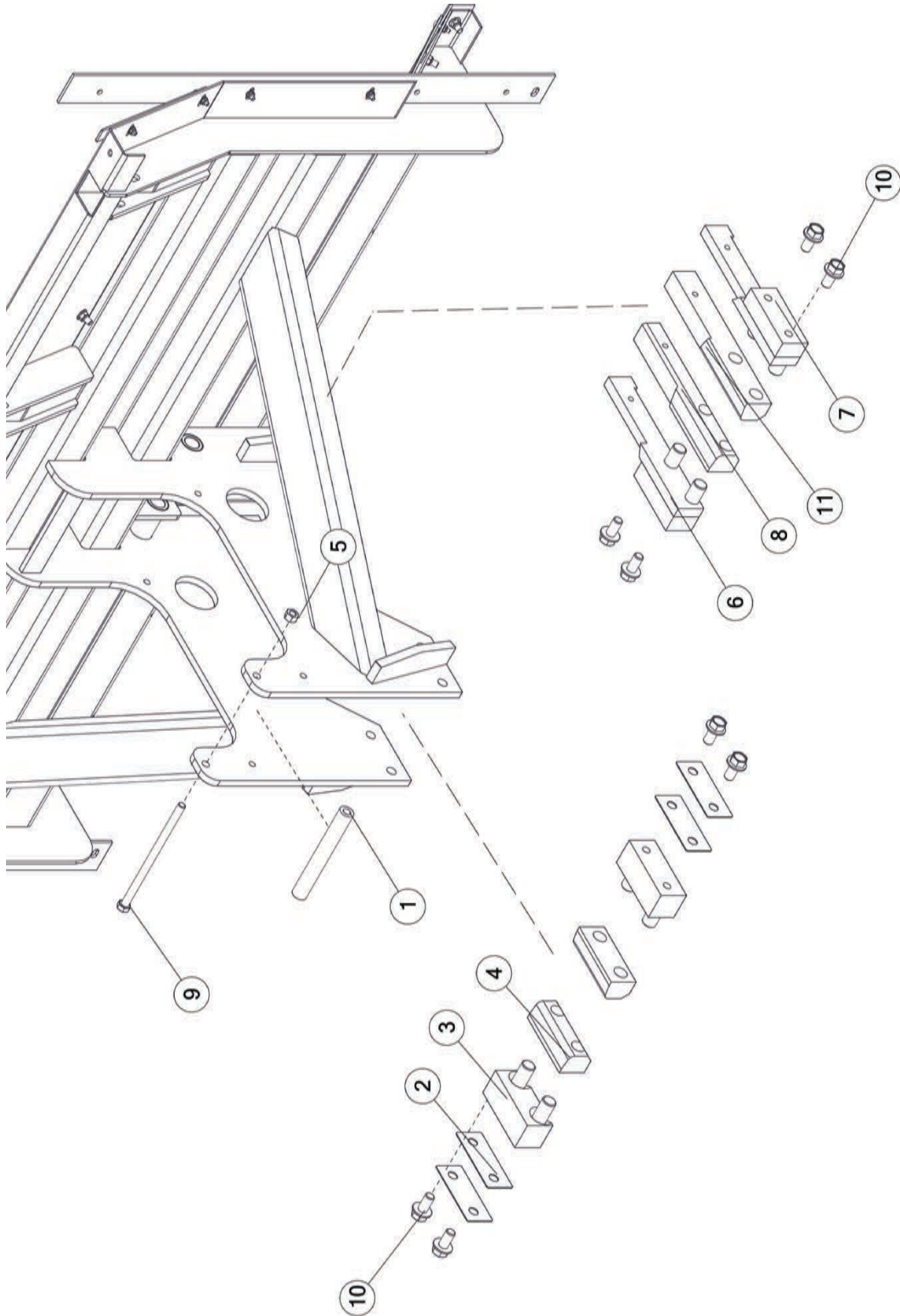



FIGURE 5 PUSHER EXTENSION & COMPONENTS

REF #	PART #	DESCRIPTION	QTY
1	88863	STONE GUARD	1
2	89640B	FRONT PANEL	1
3	90065	PUSHER EXTENSION	1
4	YBFB12350	BOLT FLANGE, 3/8 X 3-1/2 G5	4
5	YBFB12003	BOLT FLANGE, 3/8 X 1 G5	10
6	YNFG12006	NUT FLANGE, 3/8 GF	14
7	YBFB16150	BOLT FLANGE, 1/2 X 1-1/2 G5	4
8	YWFL18005	WASHER FLAT, 9/16	4
9	YNFG16003	NUT FLANGE, 1/2 GF	4





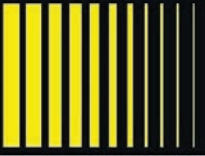

FIGURE 6 PUSHER SPACERS & COMPONENTS

REF #	PART #	DESCRIPTION	QTY
1	55N59	PUSHER SPACER	1
2	42N114	PUSHER SHIM	4
3	55N52	POLY BLOCK SPACER FRONT	2
4	55N53	PUSHER POLY SLIDE	2
5	YN16005	NUT HEX, TOP LOCK, 1/2 G5	1
6	55N54	POLY BLOCK EXTENSION RH	1
7	55N57	POLY BLOCK EXTENSION LH	1
8	55N55	PUSHER POLY SLIDE RH	1
9	YBHH16200	BOLT HEX, 1/2-13 X 10 G5 ZC	1
10	YBHH20015	BOLT HEX, 5/8 X 1-1/4 G5	8
11	55N56	PUSHER POLY SLIDE LH	1





FIGURE 7

GEARBOX DRIVE & COMPONENTS

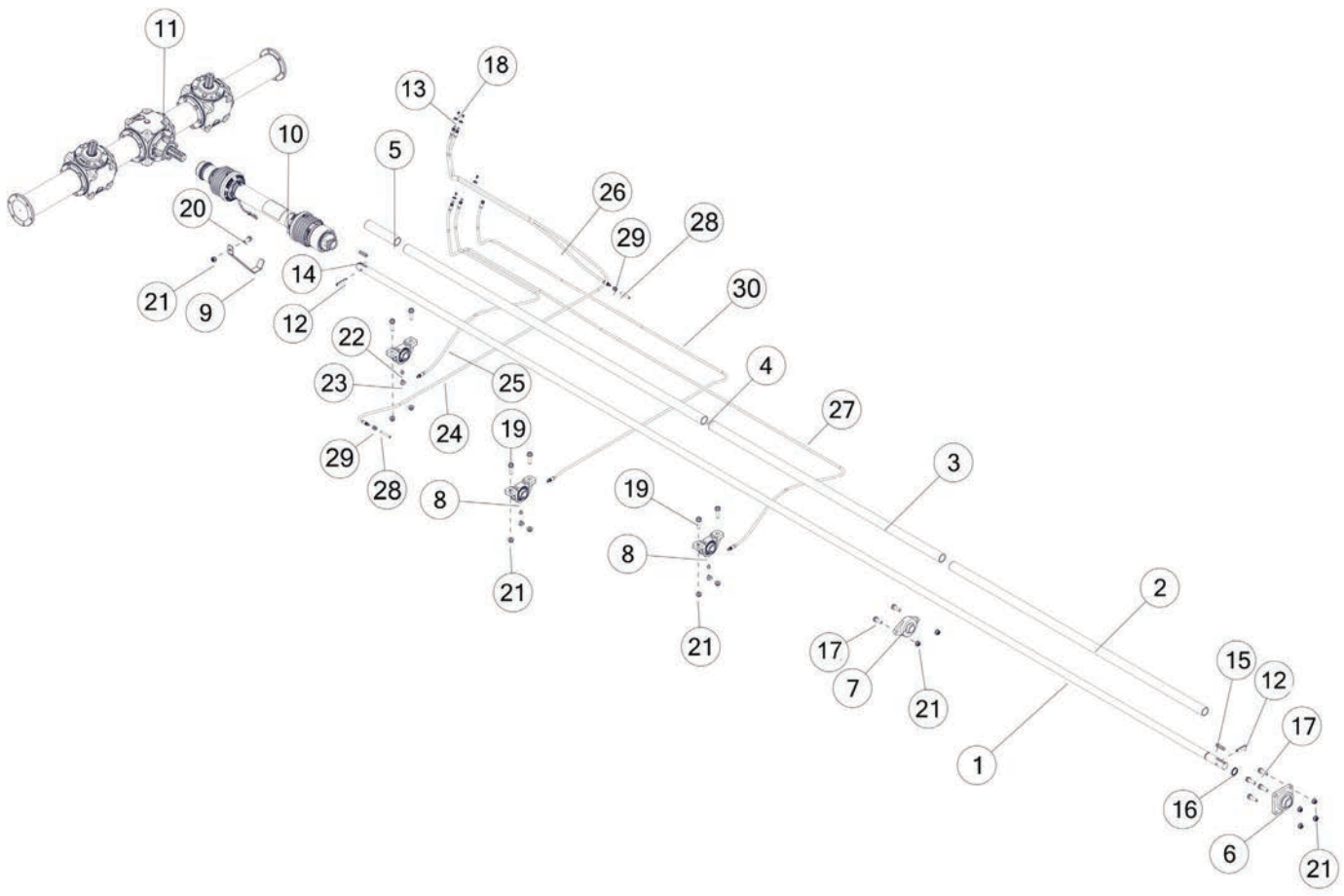
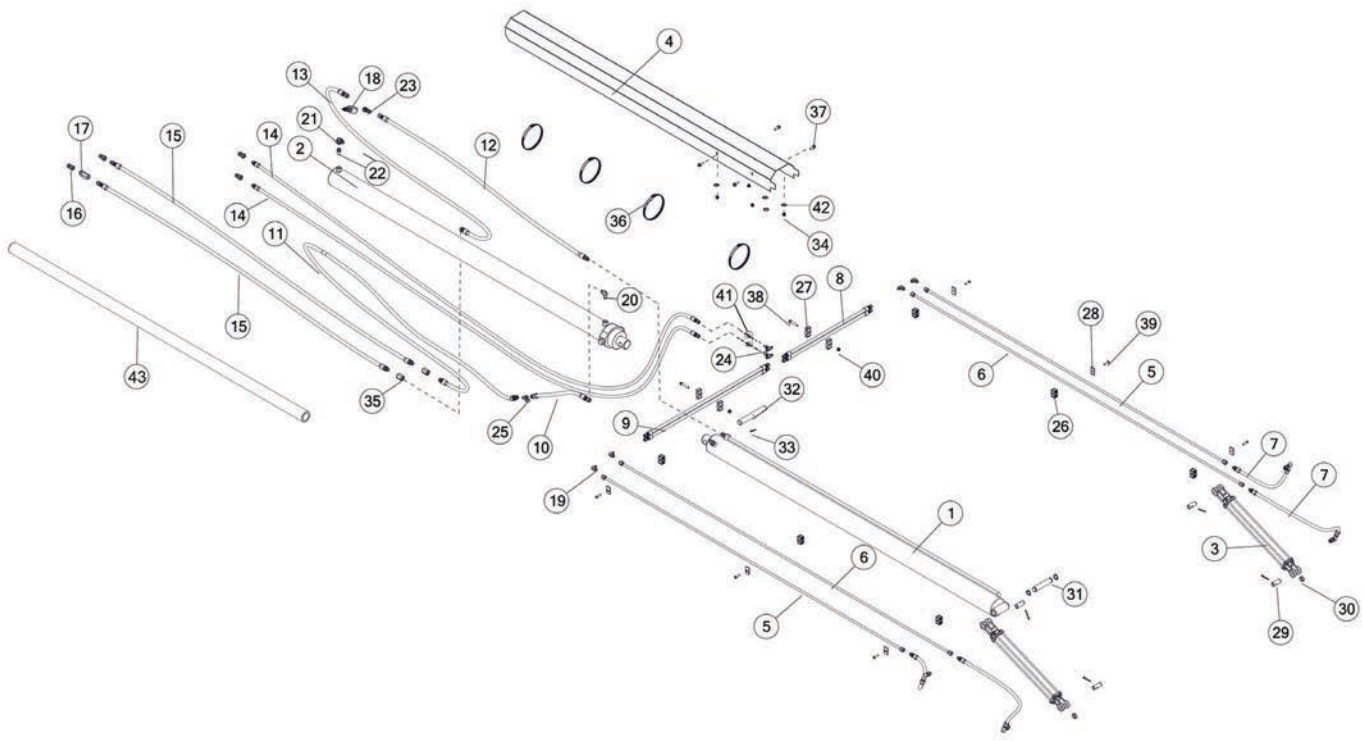



FIGURE 8 HYDRAULICS





REF #	PART #	DESCRIPTION	QTY
1	55N33	HYDRAULIC CYLINDER, TRUNNION 4.5 X 90	1
2	55N32	HYDRAULIC CYLINDER, GIMBAL 4.5 X 90	1
3	90970	HYDRAULIC CYLINDER, 2 X 20	2
4	88870B	CYLINDER SHIELD W/DECALS	1
5	90973	HYDRAULIC TUBE, 1/2 X 108	2
6	89070	HYD TUBE, 1/2 X 10 FT	2
7	90972	HYDRAULIC HOSE, 6, 36	4
8	89635	HYDRAULIC HOSE, 6, 32	2
9	89632	HYDRAULIC HOSE, 6, 45	2
10	89654	HYDRAULIC HOSE, 8, 21	1
11	89665	HYDRAULIC HOSE, 8, 166	1
12	89652	HYDRAULIC HOSE, 8, 76	1
13	89659	HYDRAULIC HOSE, 8, 90	1
14	89629	HYDRAULIC HOSE, 6, 182	2
15	89662	HYDRAULIC HOSE, 8, 110	2
16	67148	FTG, ST, 8ORB, QUICK COUPLER TIP	4
17	89576	HYDRAULIC VALVE, CHECK	1
18	89573	HYDRAULIC VALVE, SEQUENCE	1
19	58187	FITTING 8-6 ETX-S	4
20	58189	FITTING, 90, 8JIC X 1/2NPT	1
21	1056	-8ORB TO -8ORB 90 DEG	1
22	TFM89	FITTING, STRAIGHT, 8ORB X 1/2NPT	1
23	89643	FITTING T, 8JIC, 8JIC, 8ORB	1
24	8005	FITTING TEE, 8JIC X 8JIC X 8JIC, BULKHEAD	1
25	TS139	FITT T, 8JIC, 8JIC, 8JIC	1
26	TS118	LINE CLAMP BLOCK (PART OF T2008S)	6
27	86567	DOUBLE CLAMP, UNIVERSAL	4
28	56563	CLAMP TOP PLATE	6
29	56N141	CYLINDER PIN	4
30	K132	SPACER, 3/8 LONG	2
31	55N50	REAR CYLINDER PIN	1
32	55N34	CYLINDER PIN	1
33	YPCT05025	COTTER PIN, 5/32 X 2	6
34	YNHX12005	NUT HEX, 3/8 G2	4
35	90154	FITTING STRAIGHT, 10ORB, 10ORB	2
36	55N66	HOSE CLAMP SAE #104	1
37	YBFB12125	BOLT FLANGE, 3/8 X 1-1/4 G5	4
38	YBFB12250	BOLT FLANGE, 3/8 X 2-1/2 G5	2
39	56568	CLAMP BOLT 5/16-18 x 1-3/8	6





FIGURE 8 HYDRAULICS

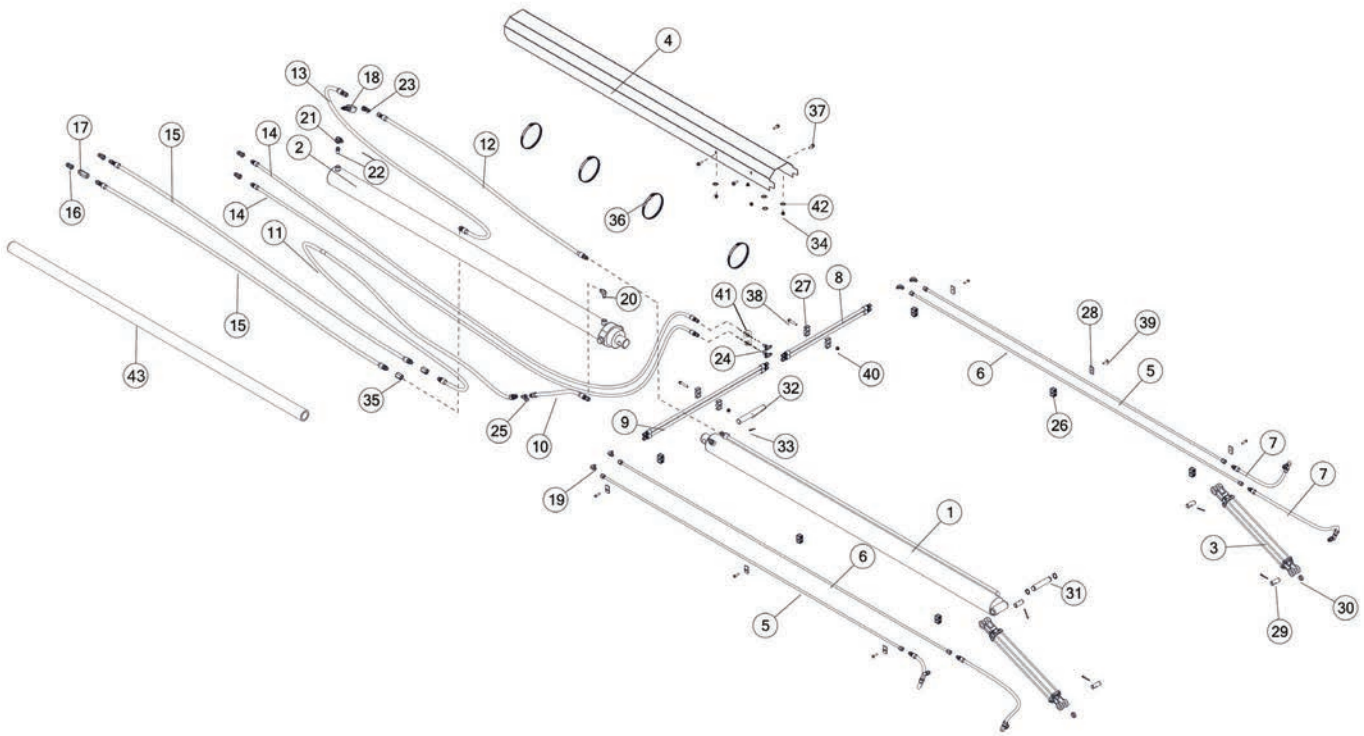



FIGURE 9 TANDEM AXLE AND WHEEL COMPONENTS

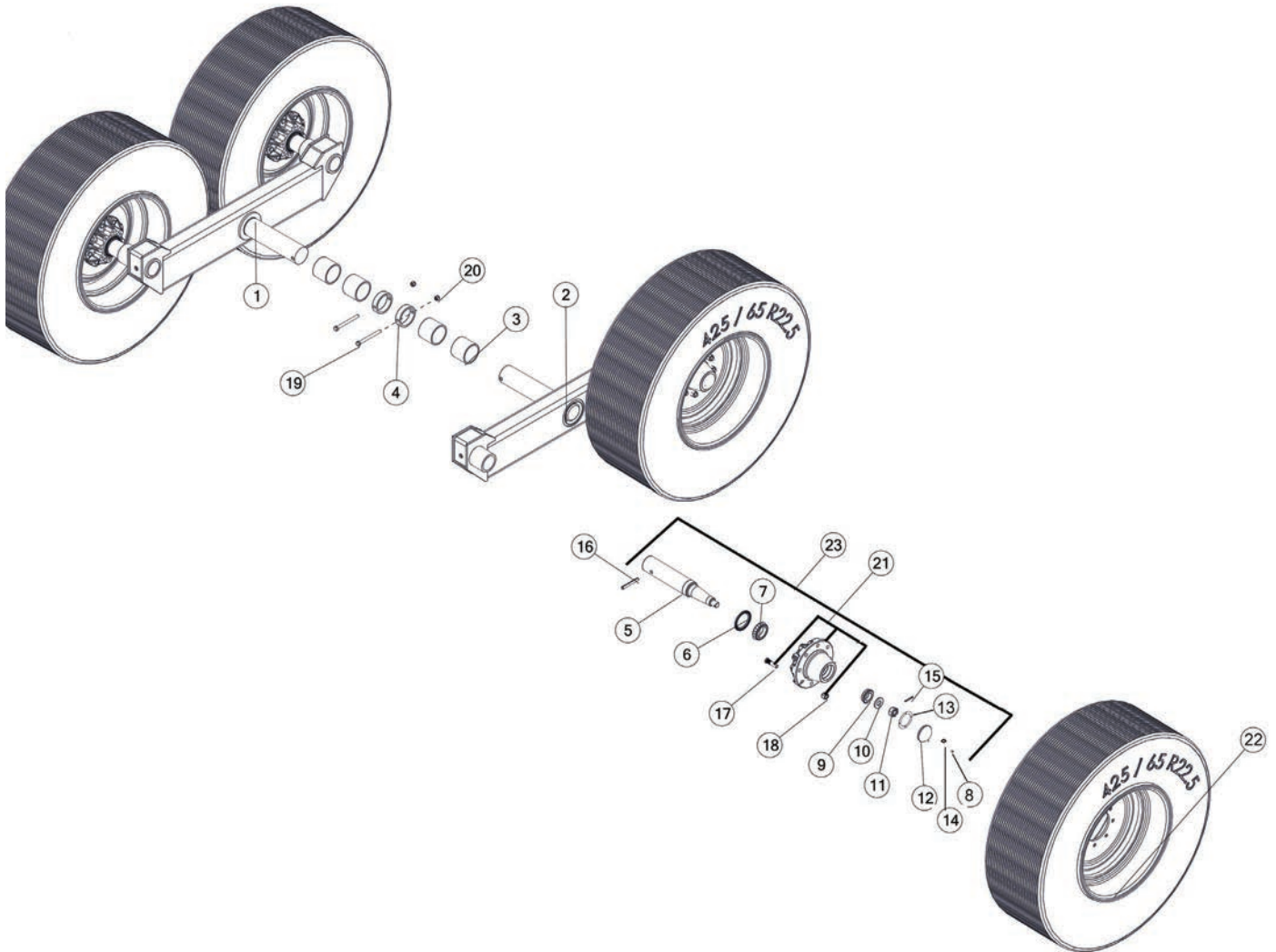



FIGURE 9 TANDEM AXLE AND WHEEL COMPONENTS

REF #	PART #	DESCRIPTION	QTY
1	55N3	TANDEM AXLE RH	1
2	55N2	TANDEM AXLE LH	1
3	70157	BUSHING, NYLATRON, 4-1/2 OD X 4 ID X 3-1/4	4
4	16SV214	AXLE MOUNT COLLAR	2
5	93127	SPINDLE, 3 X 19-1/4	4
6	93128	SEAL	4
7	54505	INNER BEARING	4
8	YBHH10105	BOLT HEX, 5/16 X 3/4 G5	16
9	54506	OUTER BEARING	4
10	93129	WASHER	4
11	YNSL36010	NUT SLOT, 1-1/4-12 NA G5	4
12	93131	HUB CAP	4
13	93130	GASKET	4
14	YWLO10005	WASHER LOCK, 5/16	16
15	YPCT08007	COTTER PIN, 1/4 X 2	4
16	YPEX16020	EXPANSION PIN, 1/2 X 4	4
17	YBSD24010	BOLT STUD, 3/4 UNF X 2-3/4	40
18	60N14	NUT HEX, FLANGE, 3/4 UNF-28 G8	40
19	YBHH16165	BOLT HEX, 1/2 X 6 G5	2
20	YNNY16005	NUT HEX, NYLON LOCKNUT, 1/2	2
21	93123	HUB	4
22	TWP42510S	(4) 425 X 22.5 USED TRUCK TIRE W/SLVR 10B RIMS	1
23	93132	HUB & SPINDLE ASSEMBLY	4
*	90195	ASSEMBLY, WHEEL AND TIRE	4
*	90188	WHEEL, 22.5 X 13.0 10 BOLT SILVER	4
*	16SV88	TIRE, 425 X 22.5	4
*	72438	VALVE STEM, 1-1/2	4





FIGURE 10 ENDGATE & COMPONENTS

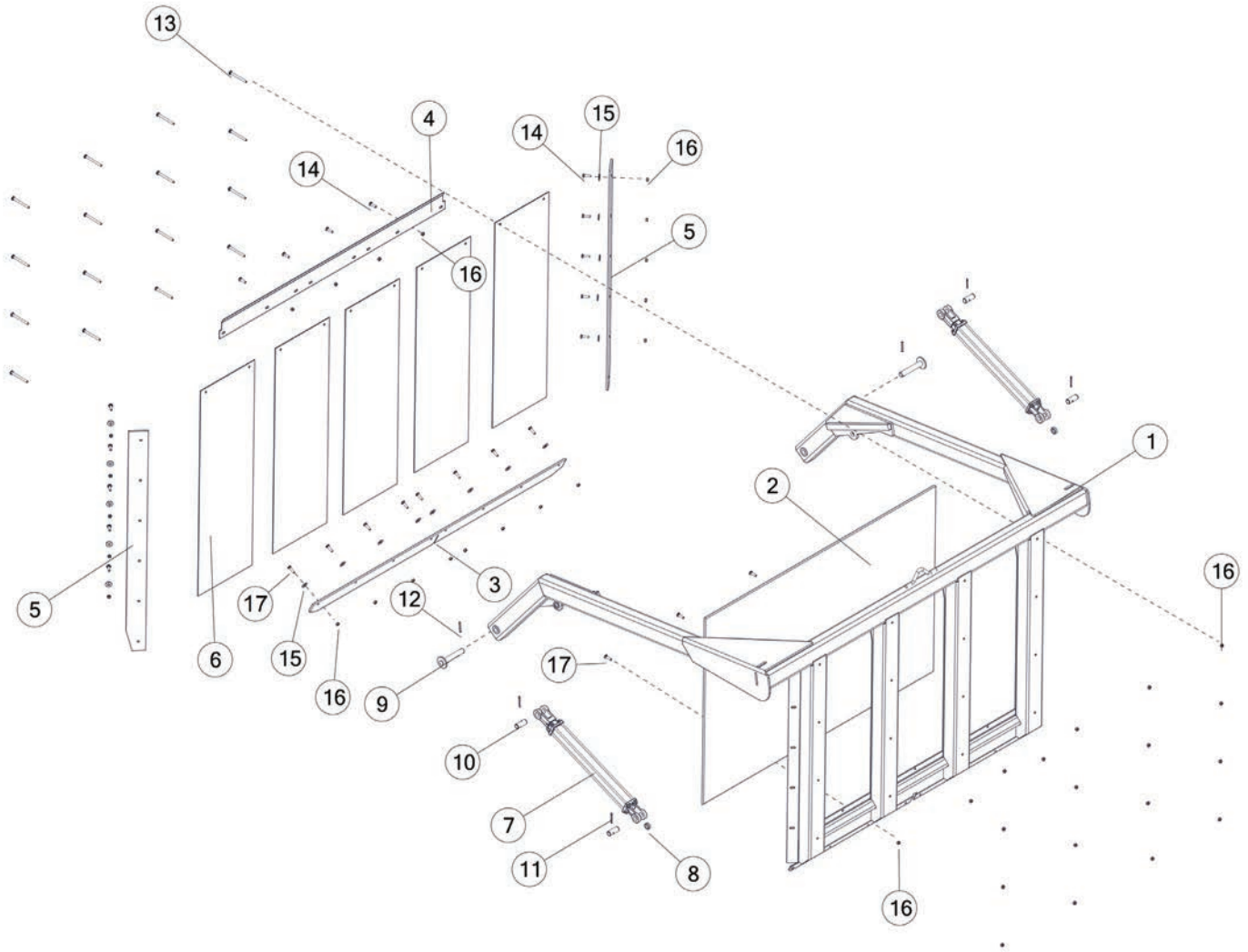



FIGURE 10

ENDGATE & COMPONENTS

REF #	PART #	DESCRIPTION	QTY
1	55N9B	ENDGATE W/DECALS	1
2	55N15	ENDGATE POLY	1
3	55N14	ENDGATE RUBBER	5
4	89823	ENDGATE POLY HOLD DOWN	1
5	55N13	ENDGATE RUBBER, LH	1
6	55N88	ENDGATE CURTAIN BELTING	1
7	90970	HYDRAULIC CYLINDER, 2 X 20	1
*	23N142A	CLEVIS CAP	1
*	56174	ROD CAP	1
*	45N43	CYLINDER TUBE	1
*	23N149	PLUG	2
*	45N44	TIE ROD	4
*	56180	PISTON	1
*	45N42	CYLINDER ROD	1
*	23N150A	ROD CLEVIS	1
*	YSSO12015	SET SCREW SOCKET, 3/8 X 3/8	1
*	23N148	PISTON NUT	1
*	56187	SEAL KIT	1
*	YNHX12006	NUT HEX, 3/8 G2	8
8	K132	SPACER, 3/8 LONG	2
9	55N10	ENDGATE PIVOT PIN	2
10	56N141	SHAFT, RND, 1 X 2-1/2, PIN, CYLINDER	1
11	YPCT05025	COTTER PIN, 5/32 X 2	2
12	YPEX12020	EXPANSION PIN, 3/8 X 2	4
13	YBCR12105	BOLT CARRIAGE, FT, 3/8-16 X 4-1/2 G5 ZC	16
14	YBCR12015	BOLT CARRIAGE, 3/8-16 X 1-1/2 G5 ZC	16
15	YWFL14005	WASHER, FLAT, 7/16	49
16	YNHX12005	NUT HEX, 3/8-16 NA A ZC	41
17	YBCR12020	BOLT CARRIAGE, 3/8 X 1-1/4 G5	16





FIGURE 11 BEATER PANELS & COMPONENTS

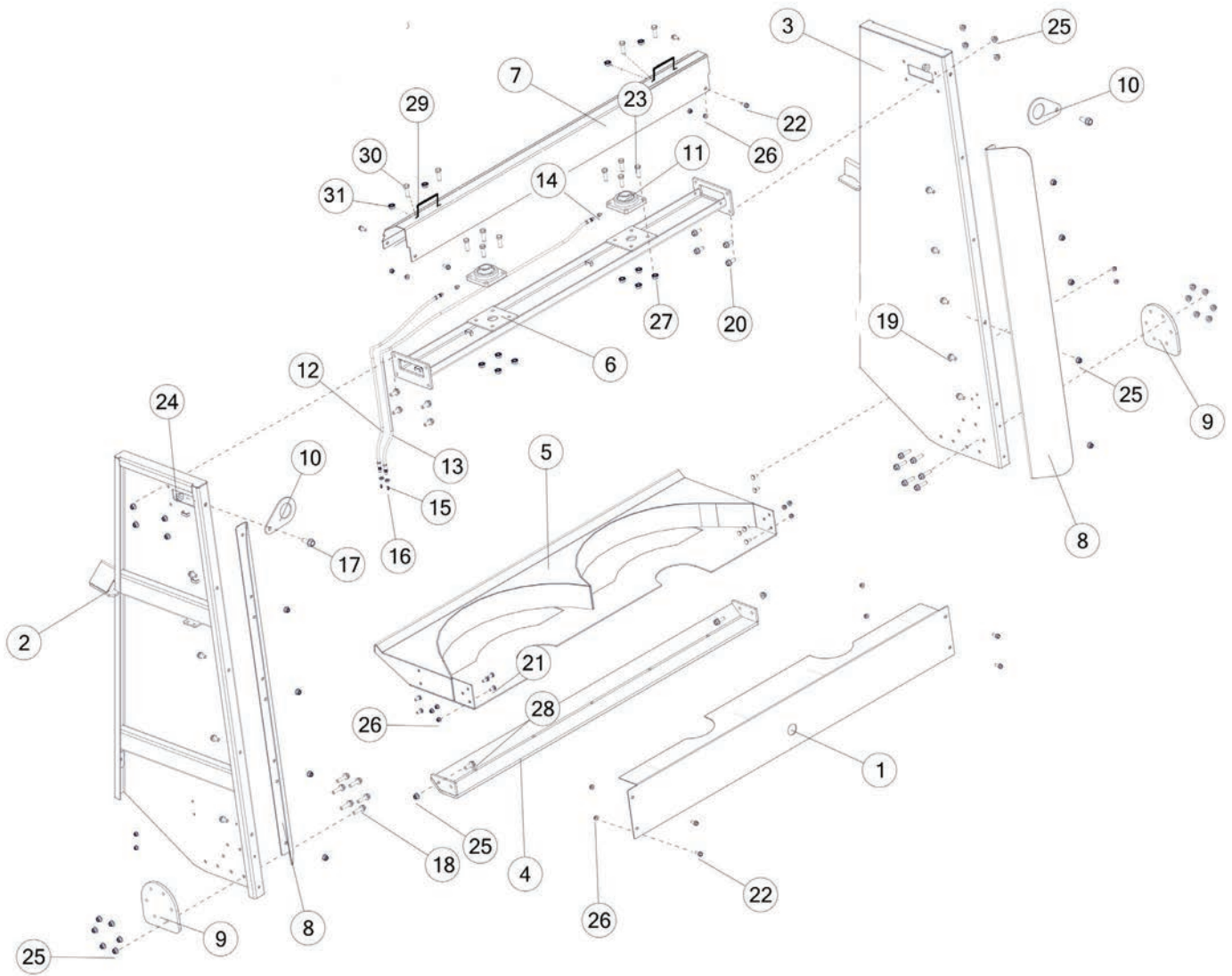



FIGURE 11

BEATER PANELS & COMPONENTS

REF #	PART #	DESCRIPTION	QTY
1	87691	GEARBOX COVER	1
2	88878B	BEATER PANEL W/DECALS LH	1
3	88883B	BEATER PANEL W/DECALS RH	1
4	90870	BEATER SKID PLATE	1
5	87622	BEATER PAN	1
6	87578B	UPPER BEARING MOUNT W/DECALS	1
7	87579B	BEARING SHIELD W/DECALS	1
8	90248	BEATER DEFLECTOR	2
9	87568	BEATER SUPPORT LEG	2
10	HGV50	LIFTING EYE	2
11	12V99	BEARING, 5.13 X 1.50 X 2.02, FLANGE	2
12	89747	GREASE HOSE, 3, 100	1
13	88909	GREASE HOSE, 3, 66	1
14	TS323	FITTING STRAIGHT, 1/4-28, 1/8-27NPT	2
15	YNJM04005	NUT, JAM, 1/8 A	2
16	G89	STRAIGHT ZERK, 1/4-28	2
17	YBFB20175	BOLT FLANGE, 5/8 X 1-3/4 G5	2
18	YBHH16065	BOLT HEX, 1/2-13 X 2 G5 ZC	12
19	YBFB16100	BOLT FLANGE, 1/2 X 1 G5	10
20	YBFB16125	BOLT FLANGE, 1/2 X 1-1/4 G5	8
21	YBCR12010	BOLT CARRIAGE, 3/8-16 X 1 G5 ZC	6
22	YBFB12003	BOLT FLANGE, 3/8 X 1 G5	8
23	YBHH18010	BOLT HEX, 9/16 X 1-3/4 G5 ZINC	8
24	YNFG20005	NUT FLANGE, 5/8-11 LKTL F ZC	2
25	YNFG16003	NUT FLANGE, 1/2 GF	24
26	YNFG12006	NUT FLANGE, 3/8 GF	8
27	YNSF18005	NUT FLANGE, 9/16-12 LKSF CH ZC	8
28	YBFB16150	BOLT FLANGE, 1/2 X 1-1/2 G5	2
29	TS96	SHIELD HANDLE	2
30	YBHH08100	BOLT HEX, 1/4 X 3/4 G5	4
31	YNFG08010	NUT FLANGE, 1/4 GF	4





FIGURE 12 BEATERS & COMPONENTS

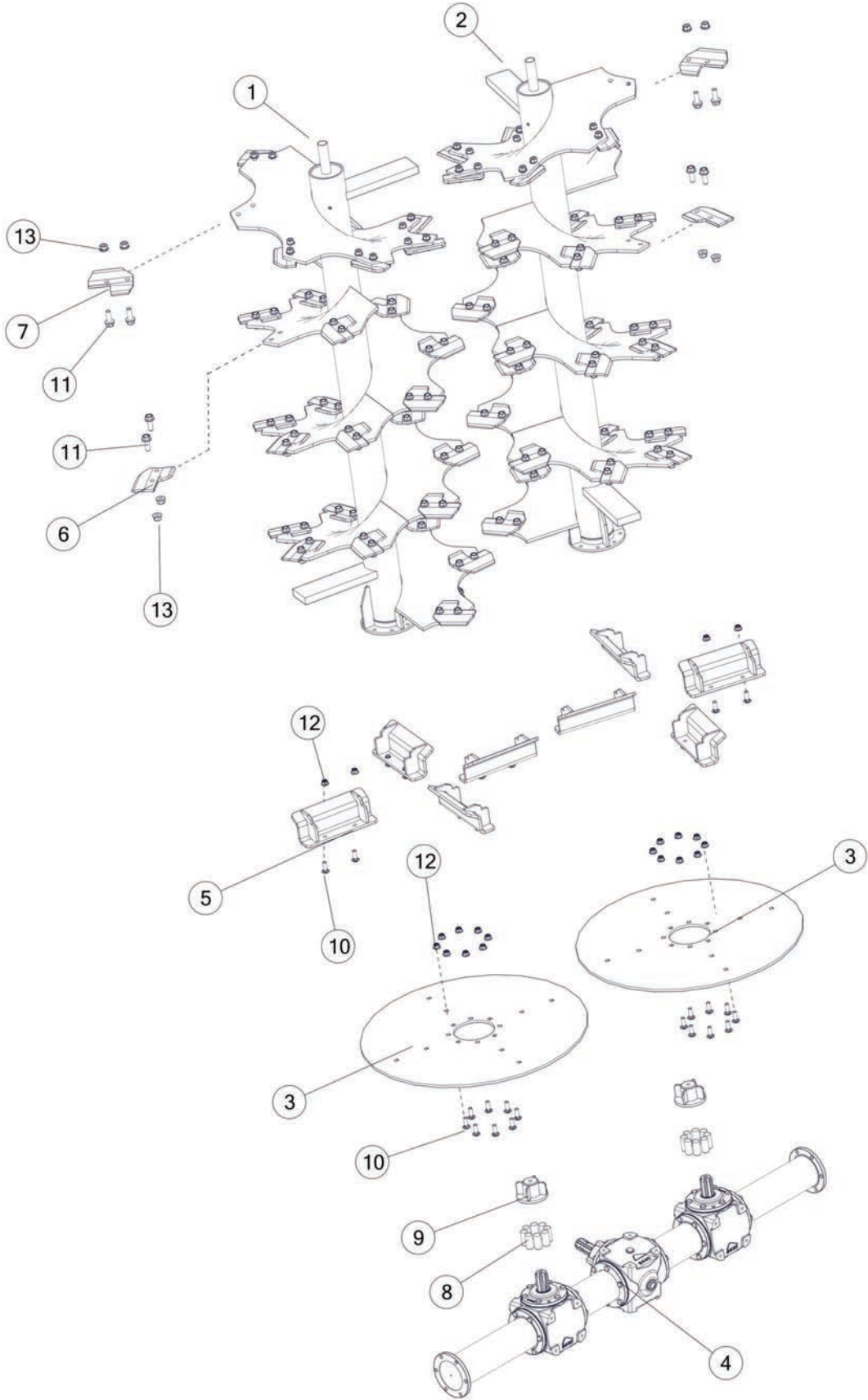



FIGURE 13

LIGHTS

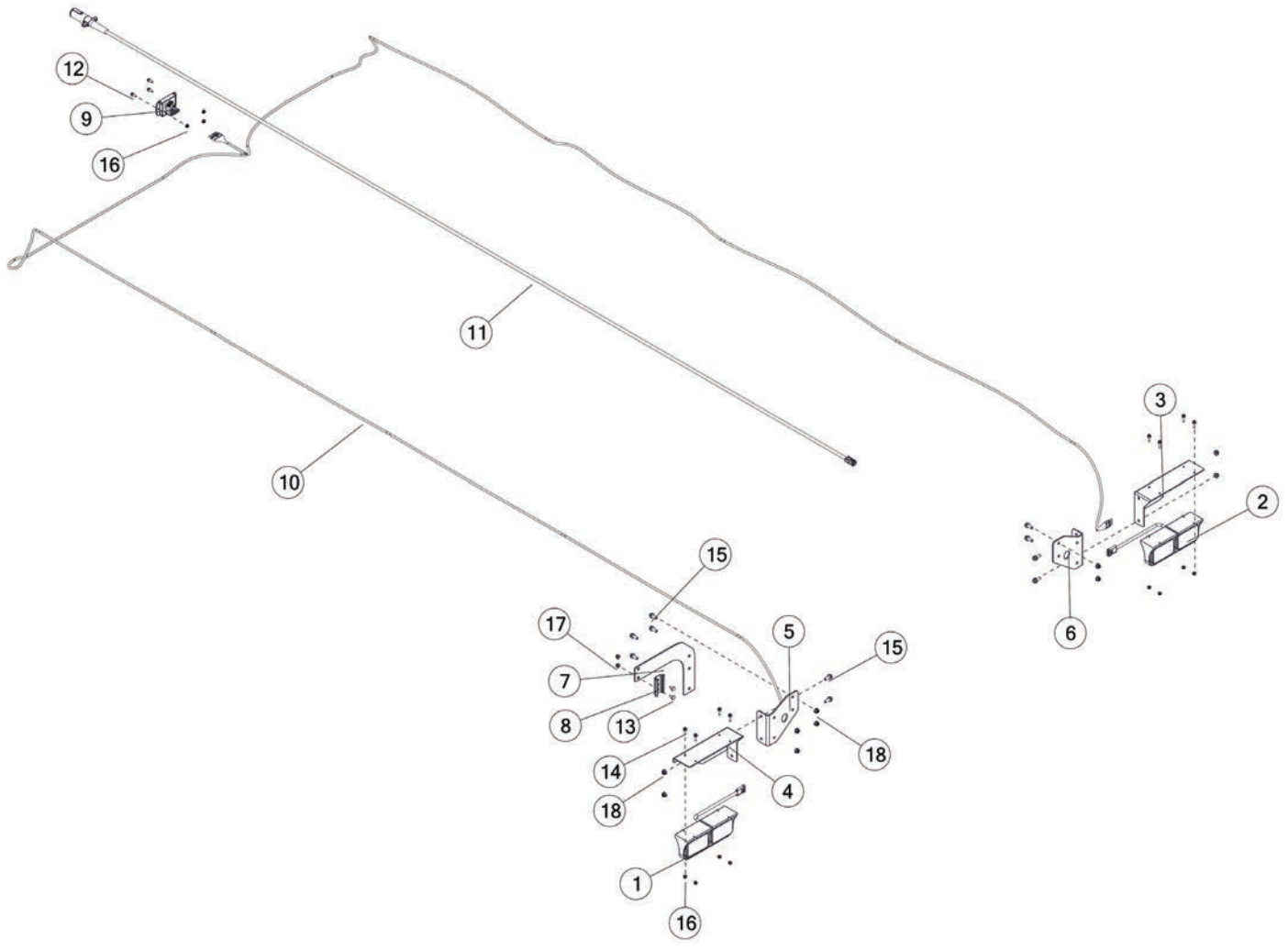



FIGURE 13
LIGHTS

REF #	PART #	DESCRIPTION	QTY
1	TFM71	TAIL LIGHT, LH	1
2	TFM72	LED TAIL LIGHT ASSY, RH	1
3	90915B	LIGHT BRACKET W/DECALS, RH	1
4	90914B	LIGHT BRACKET W/DECALS, LH	1
5	90917	LIGHT BRACKET MOUNT, LH	1
6	90918	LIGHT BRACKET MOUNT, RH	1
7	42N43	SMV BRACKET	1
8	F97	SMV HOLDER	1
9	69908	MODULE, CONTROL, BLINKER	1
10	90927	ELECTRICAL HARNESS, TAILLIGHTS	1
11	94018	WIRE HARNESS	1
12	YBFB08075	BOLT FLANGE, 1/4 X 3/4 G5	3
13	YBCR10030	BOLT CARRIAGE, 5/16-18 X 3/4 G5 ZC	2
14	YBFB08100	BOLT FLANGE, 1/4 X 1 G5	8
15	YBFB12003	BOLT FLANGE, 3/8 X 1 G5	10
16	YNFG08010	NUT FLANGE, 1/4 GF	11
17	YNFG10005	NUT FLANGE, 5/16 GF	2
18	YNFG12006	NUT FLANGE, 3/8 GF	10





FIGURE 14
BEATER GEARBOX ASSEMBLY

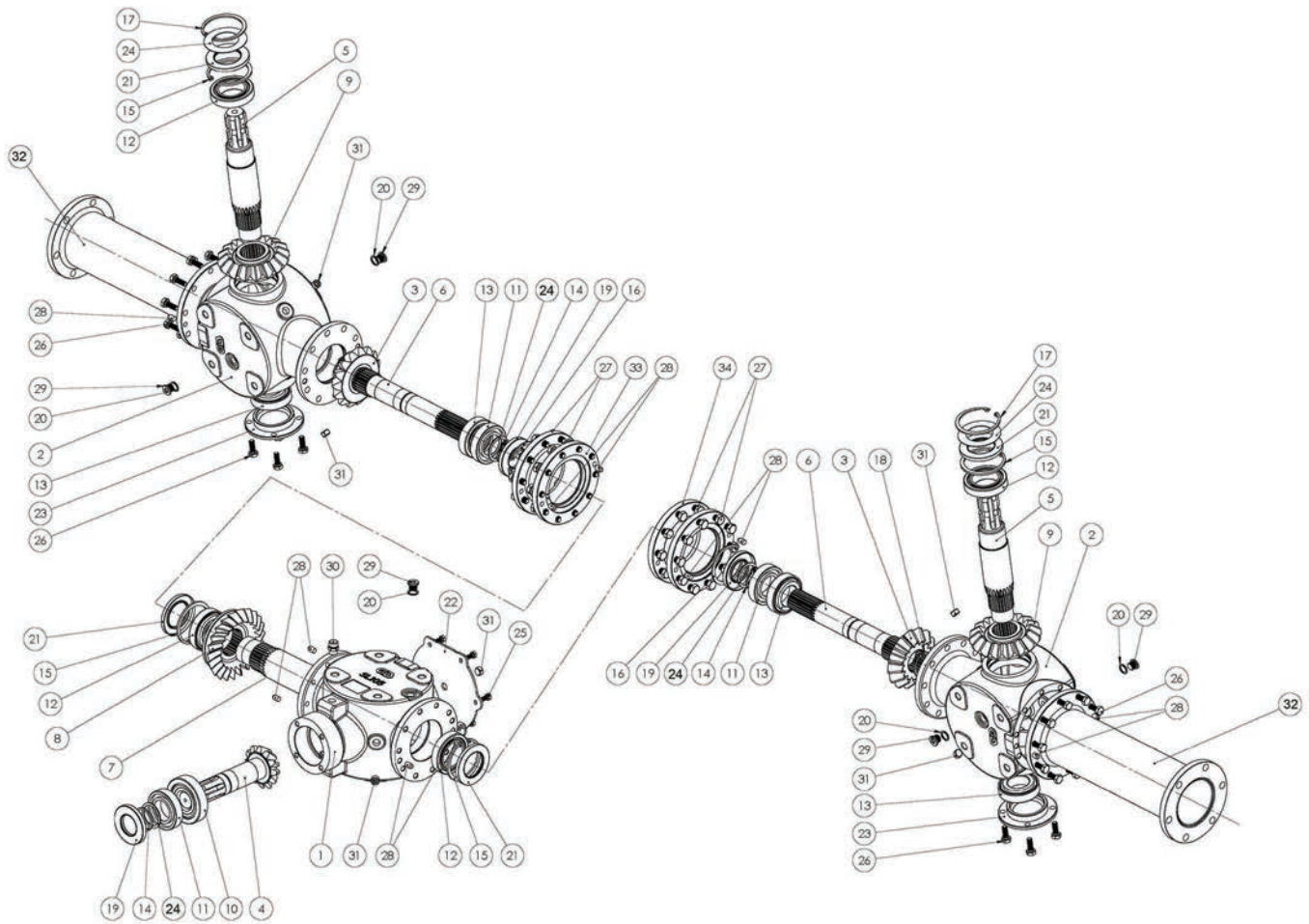



FIGURE 14

BEATER GEARBOXASSEMBLY

REF #	PART #	DESCRIPTION	QTY
1	92998	CENTER HOUSING	1
2	92999	OUTER HOUSING	2
3	93086	GEAR	2
4	93011	INPUT SHAFT	1
5	93012	OUTPUT SHAFT	2
6	93090	SHAFT	2
7	93080	CENTRAL SHAFT	1
8	93079	CROWN GEAR	1
9	93085	CROWN GEAR	2
10	93969	BEARING	1
11	93009	BEARING	3
12	93082	BEARING	4
13	93081	BEARING	4
14	93013	SNAP RING	3
15	93083	SNAP RING	4
16	93087	SNAP RING	2
17	93005	SNAP RING	2
18	93091	SNAP RING	2
19	93015	SEAL	3
20	93017	SEAL	6
21	93006	COVER	4
22	93010	COVER PLATE	1
23	93008	BASE PLATE	2
24	93007	SHIM KIT	3
25	YBHH74016	BOLT HEX, M8-1.25 X 16 8.8 ZC	6
26	YBHH76030	BOLT HEX, M10-1.5 X 30 8.8 ZC	28
27	YBHH78015	BOLT HEX, M12-1.75 X 30 8.8 ZC	40
28	93016	PIN	12
29	93003	OIL PLUG	6
30	93002	BREATHER	1
31	93004	OIL PLUG	8
32	93000	OUTER SUPPORT	2
33	93001	CENTER SUPPORT, RH	1
34	93976	CENTER SUPPORT, LH	1





FIGURE 15

OPTIONAL FLOW CONTROL (HPOVSC)

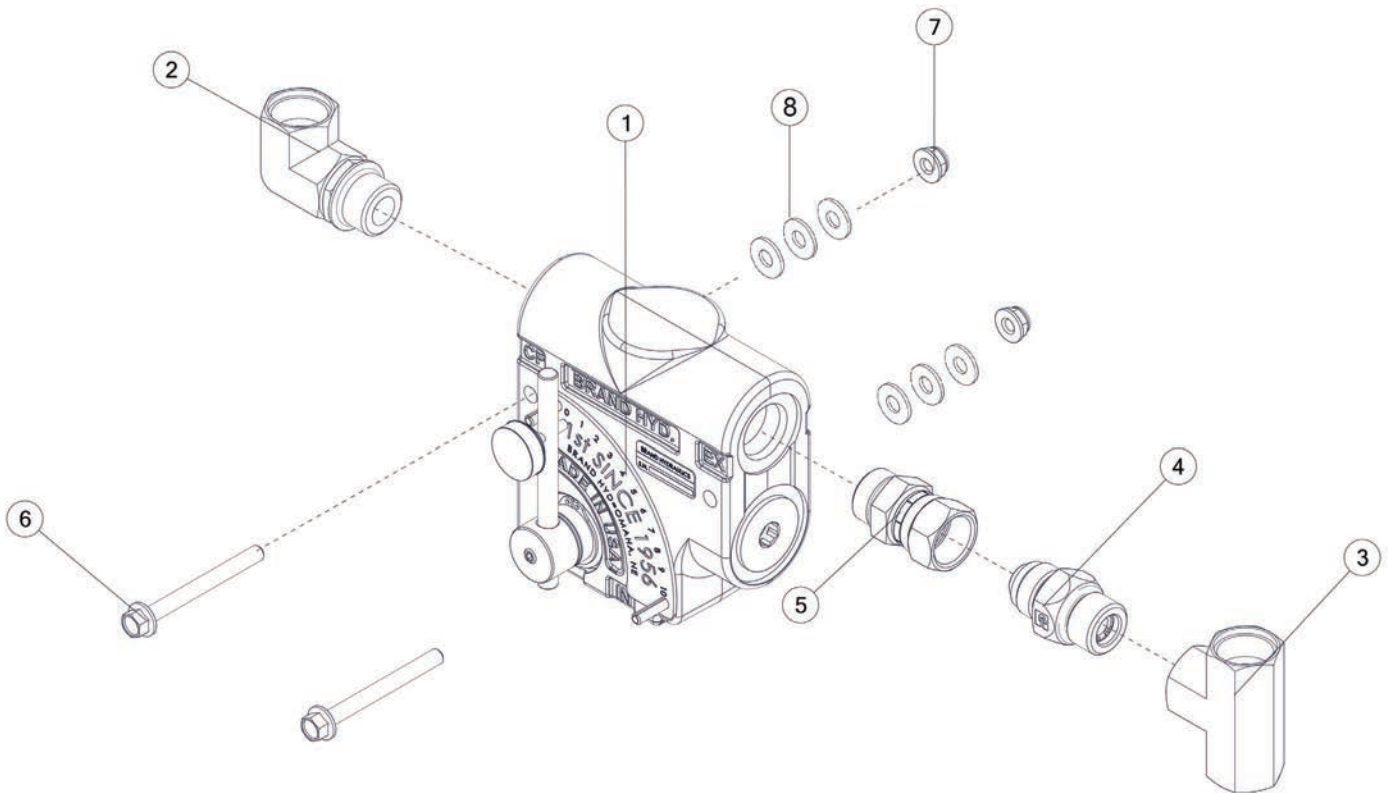



FIGURE 16

OPTIONAL VARIABLE SPEED CONTROL (HPOVSEC)

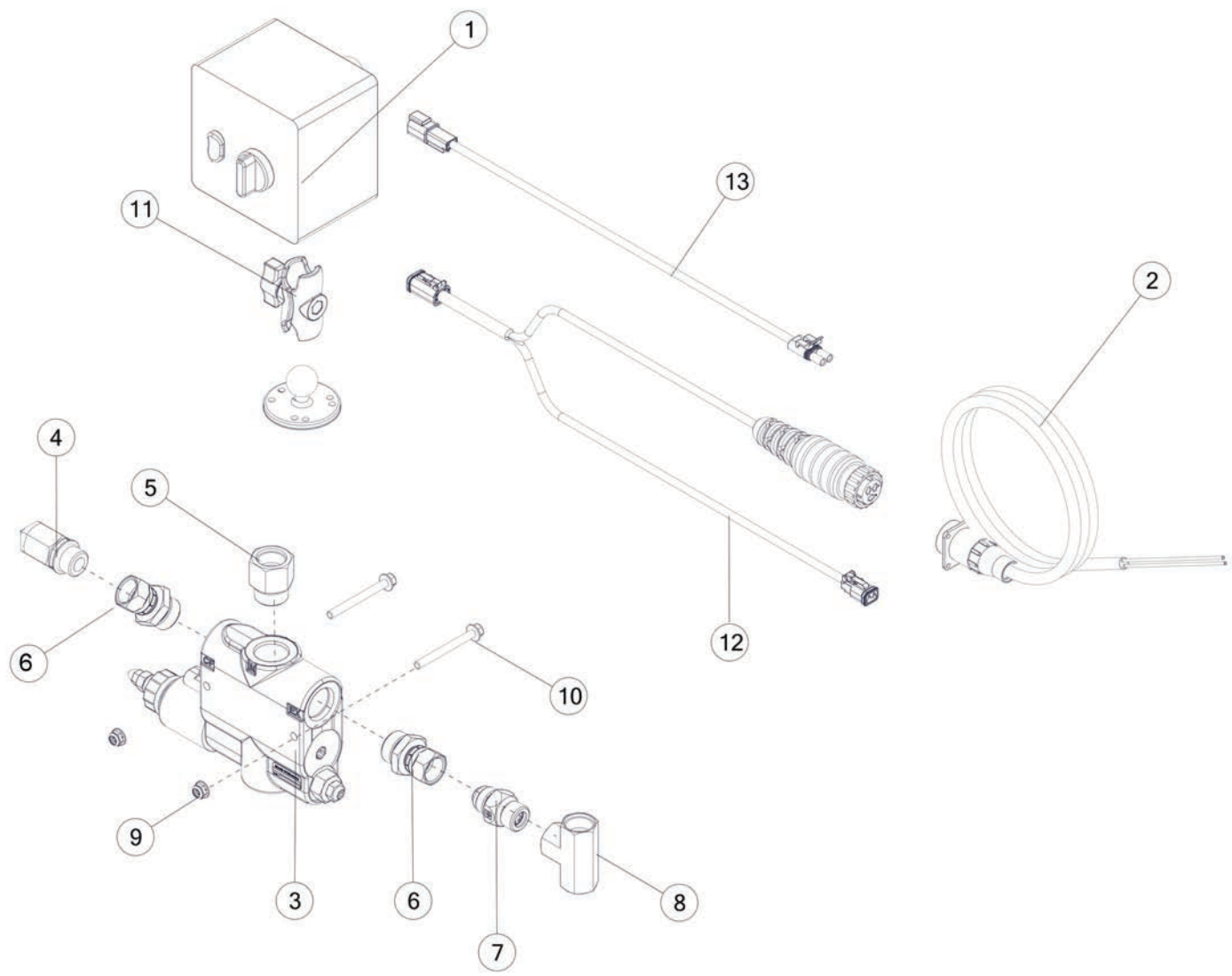



FIGURE 16

OPTIONAL VARIABLE SPEED CONTROL (HPOVSEC)

REF #	PART #	DESCRIPTION	QTY
1	91719	CONTROL BOX	1
2	16SV269	TRACTOR CONTROL CABLE	1
3	89668	ELECTRIC FLOW CONTROL	1
4	GM56	FITTING 90, 10JIC, 10ORB	1
5	69135	FITTING STRAIGHT, 12ORB, 10ORB	1
6	91704	FITTING STRAIGHT, 10JIC, 12ORB	2
7	91722	FITTING STRAIGHT, 10JIC, 10ORB, CHECK	1
8	91707	FITTING TEE, 10ORB, 10ORB, 10ORB	1
9	YNFG08010	NUT FLANGE, 1/4 GF	2
10	YBFB08250	BOLT FLANGE, 1/4 X 2-1/2 G5	2
11	85272	RAM DOUBLE SOCKET SHORT ARM	1
12	91713	CAB HARNESS	1
13	91712	IMPLEMENT HARNESS	1





FIGURE 17
OPTIONAL SCREEN EXTENSION
(HPOFASE)

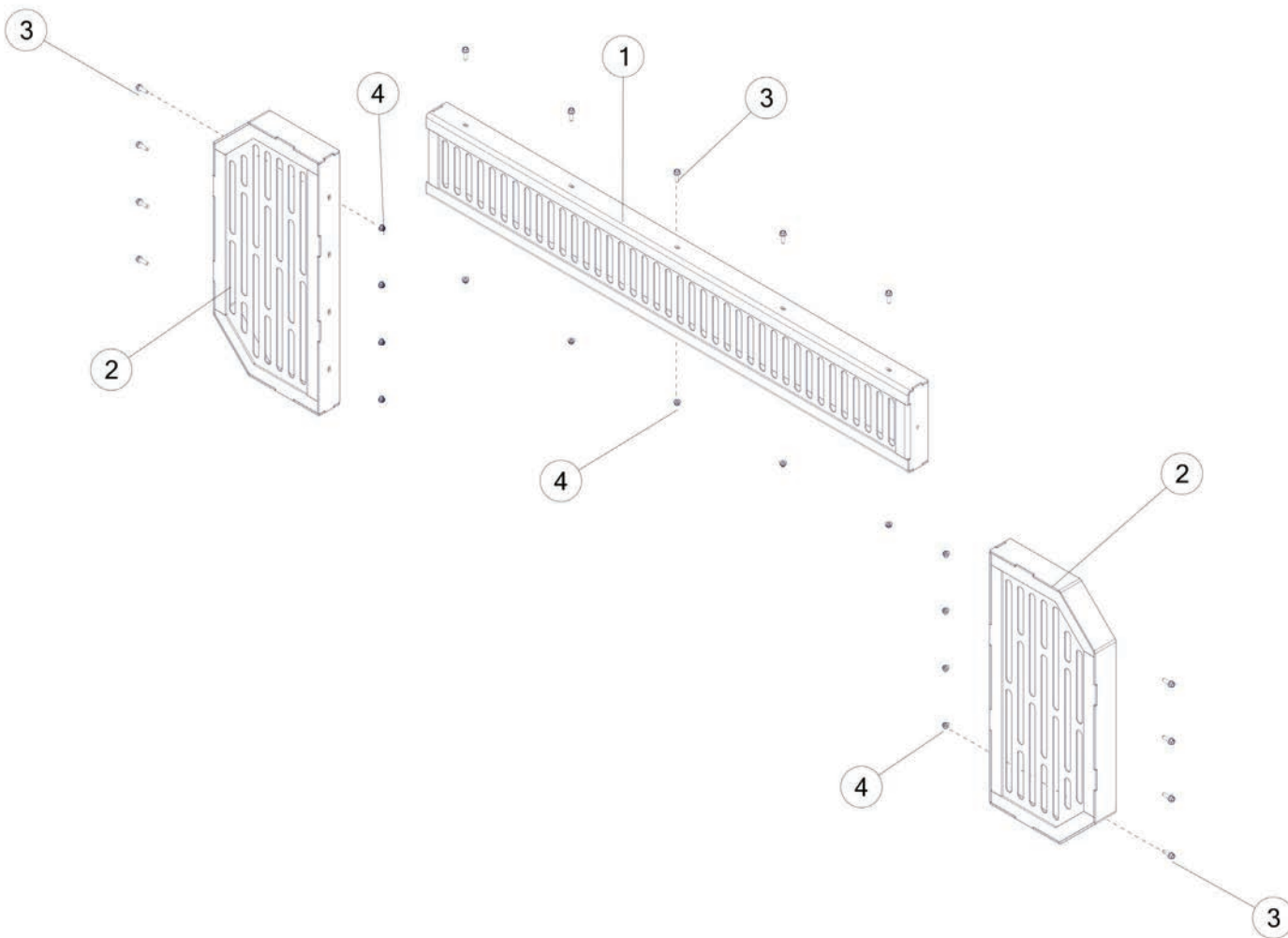



FIGURE 18
HPO1034CV PTO

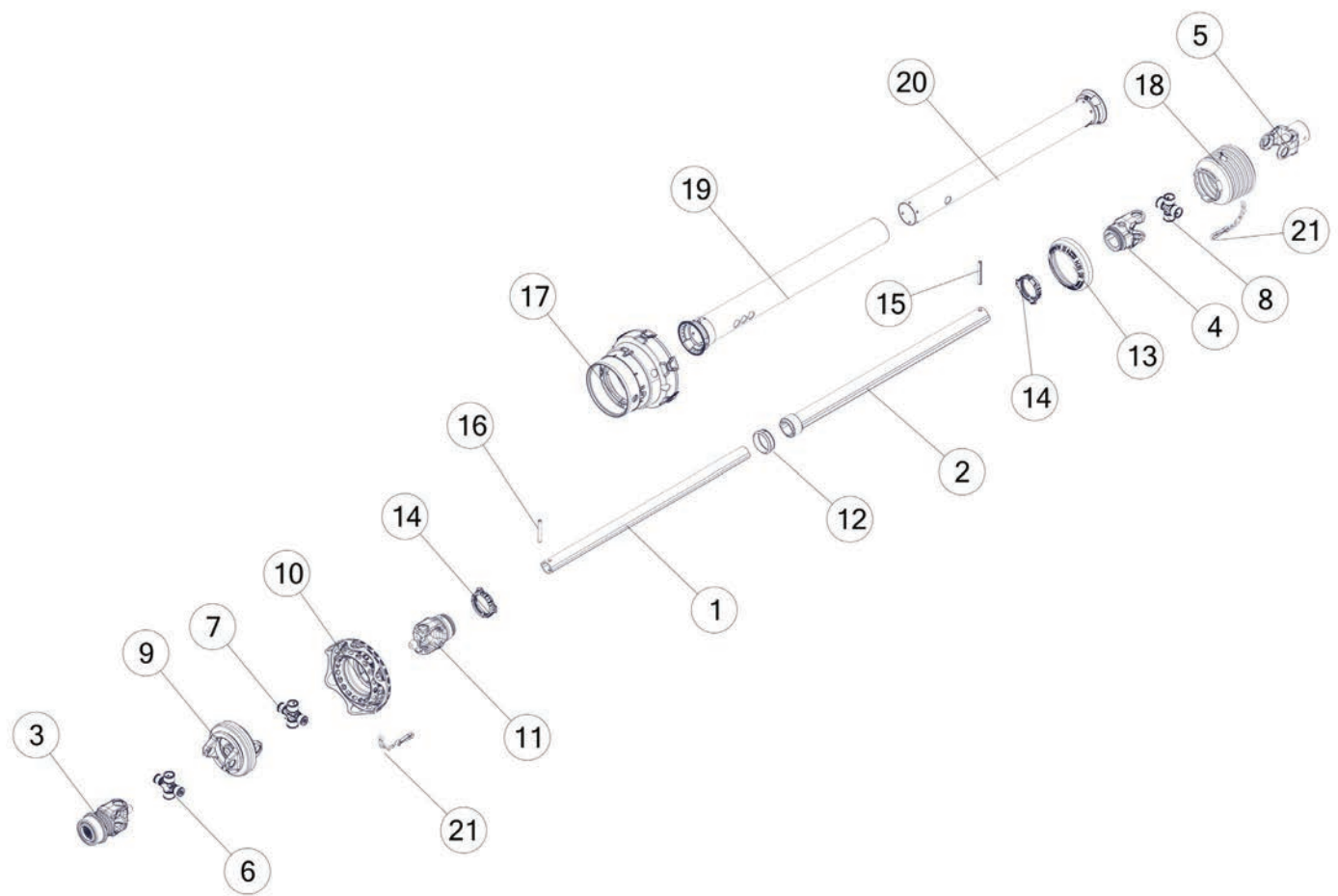



FIGURE 18

HPO1034CV PTO

REF #	PART #	DESCRIPTION	QTY
1	89772	INNER SHAFT	1
2	89790	OUTER SHAFT	1
3	89799	YOKE	1
4	89787	YOKE	1
5	89789	YOKE	1
6	89768	CROSS AND BEARING KIT	1
7	89770	CROSS AND BEARING KIT	1
8	89786	CROSS AND BEARING KIT	1
9	89769	DOUBLE YOKE	1
10	89776	NET GUARD	1
11	89771	INBOARD YOKE	1
12	89793	SUPPORT BEARING	1
13	89792	REINFORCING COLLAR	1
14	87919	BEARING RING	2
15	87920	SPRING PIN	1
16	89773	SPRING PIN	1
17	89784	CV GUARD	1
18	87926	GUARD CONE	1
19	89774	OUTER GUARD TUBE	1
20	89791	GUARD TUBE INNER	1
21	87916	RESTRAINT CHAIN	2
*	89800	COMPLETE PTO	1





FIGURE 19
HPO1038CV PTO

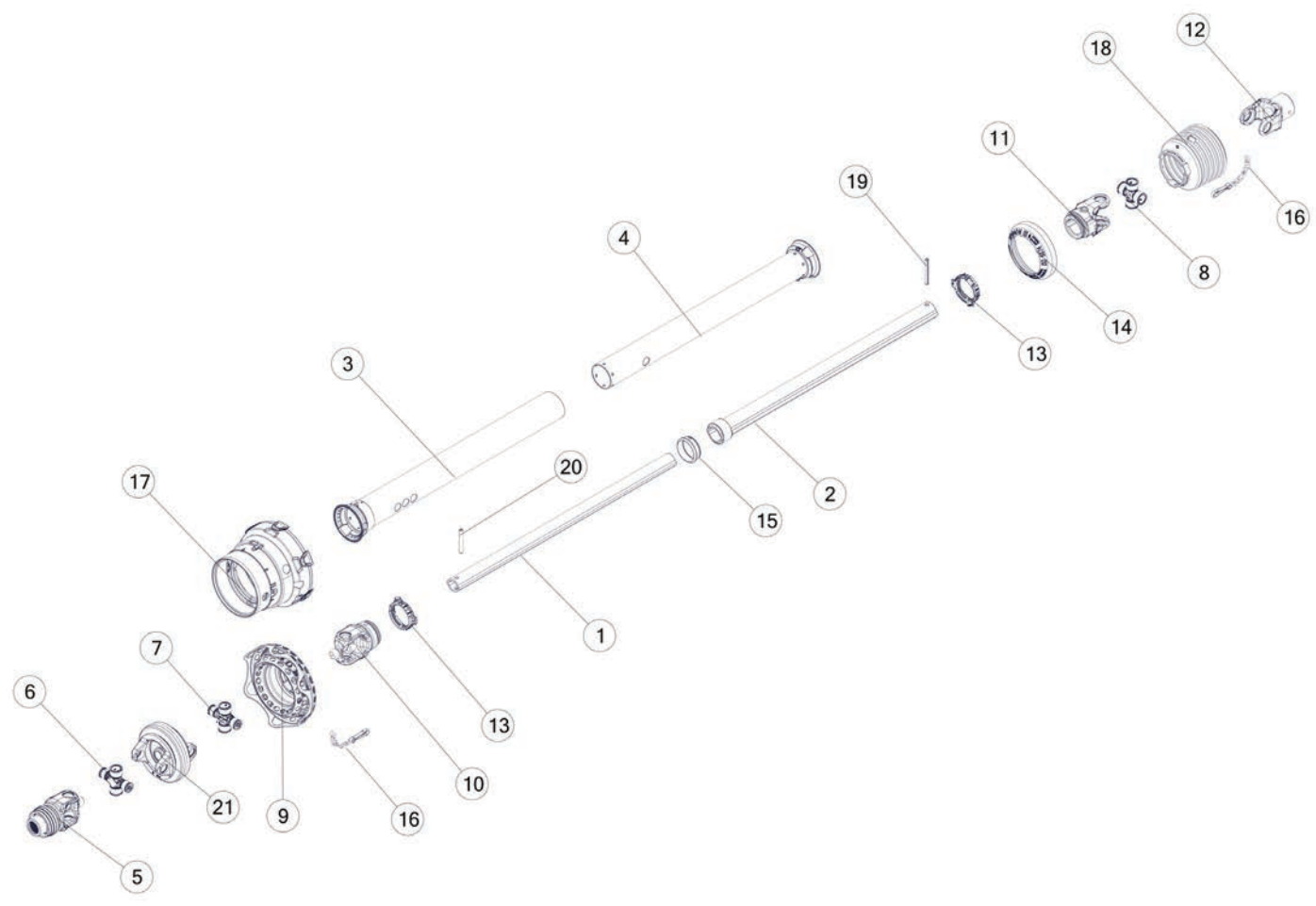



FIGURE 20

1000 RPM PTO

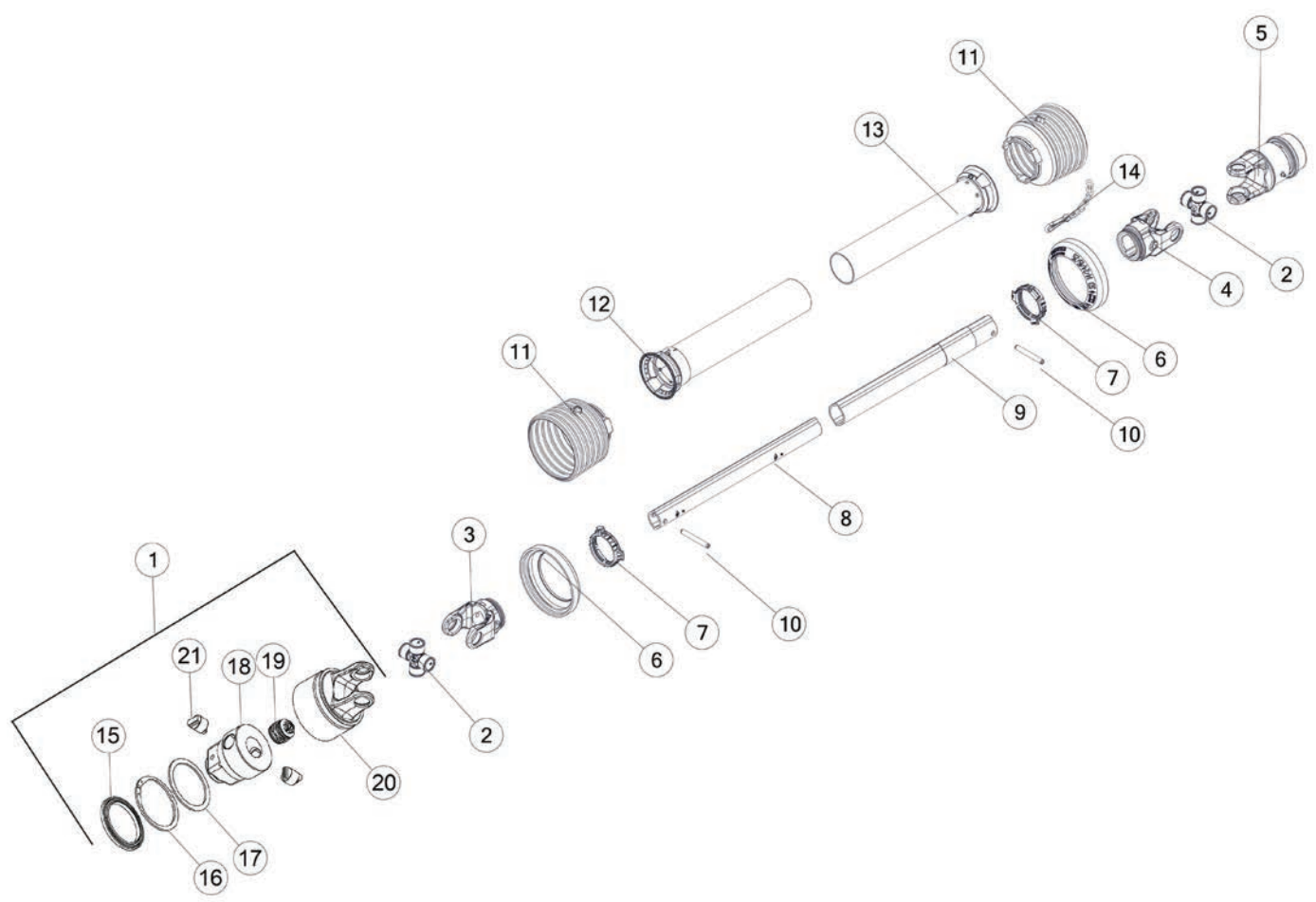



FIGURE 20
1000 RPM PTO

REF #	PART #	DESCRIPTION	QTY
1	87929	CUT OUT CLUTCH	1
2	87923	CROSS BEARING KIT	2
3	87922	YOKE	1
4	89787	YOKE	1
5	87928	OVERRUNNING CLUTCH	1
6	87918	REINFORCING COLLAR	2
7	87919	BEARING RING	2
8	87930	INNER SHAFT	1
9	87934	OUTER SHAFT	1
10	87920	SPRING PIN	2
11	87927	GUARD CONE	2
12	87931	OUTER GUARD TUBE	1
13	87936	INNER GUARD TUBE	1
14	87916	RESTRAINT CHAIN	1
15	95614	SEALING RING	1
16	95615	RETAINING RING	1
17	95616	WASHER	1
18	95617	HUB	1
19	95605	SPRING PACK, 1200NM	1
20	95618	CLUTCH HOUSING	1
21	95619	CLUTCH CAM	2
*	87914	COMPLETE PTO, 1-3/4 1000 RPM	1



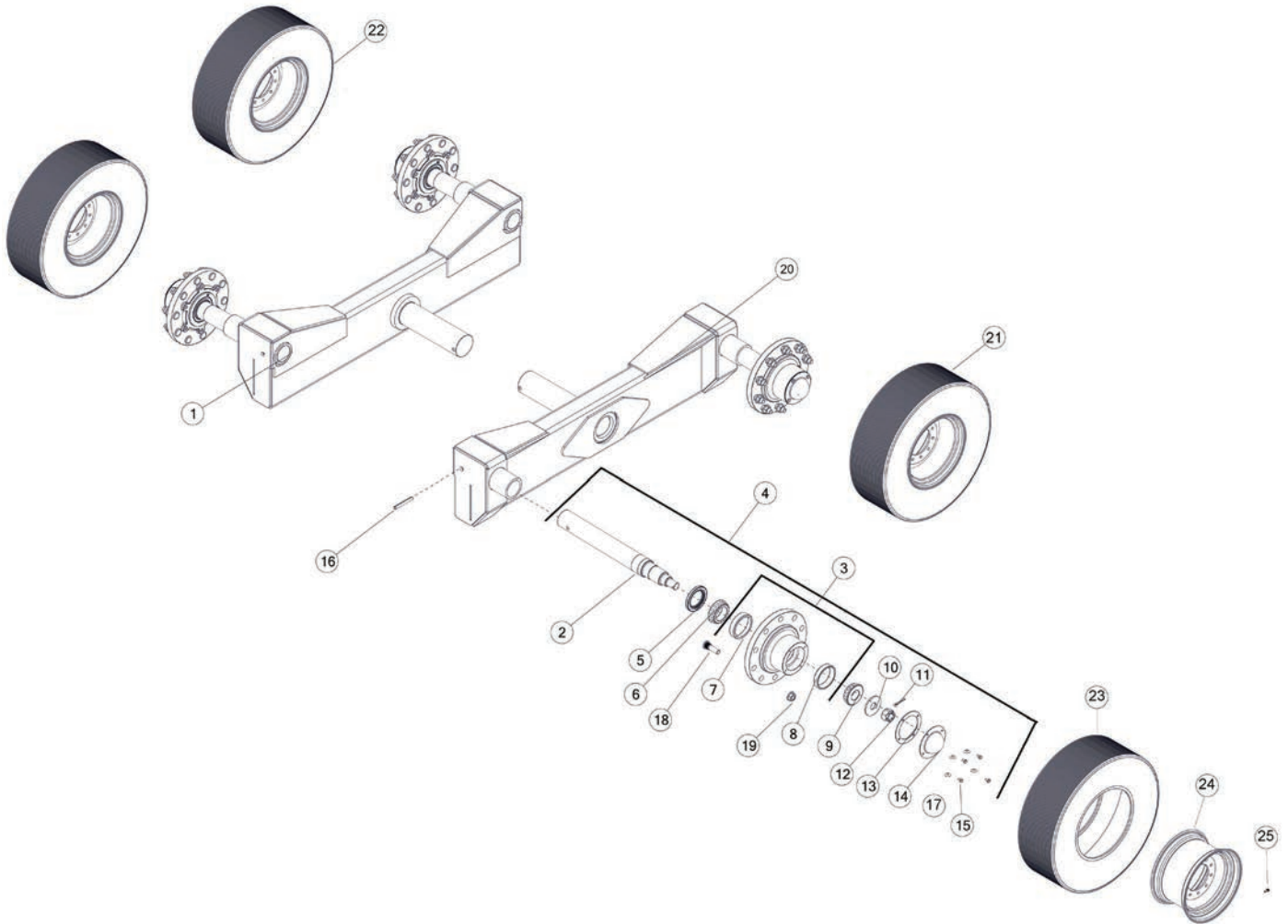



FIGURE 21

OPTIONAL TWP600S (HPOHTA550)

REF #	PART #	DESCRIPTION	QTY
1	59596	TANDEM AXLE, RH	1
2	93135	SPINDLE, 3 X 25-3/4	4
3	93123	HUB	4
4	93136	HUB AND SPINDLE ASSEMBLY	4
5	93128	SEAL	4
6	54505	TAPERED ROLLER BEARING, 2.495 BORE	4
7	54504	INNER RACE	4
8	54503	OUTER RACE	4
9	54506	TAPERED ROLLER BEARING, 1.75 BORE	4
10	93129	WASHER	4
11	YPCT08007	COTTER PIN, 1/4 X 2	4
12	YNSL36010	NUT SLOT, 1-1/4-12 NA G5	4
13	93130	GASKET	4
14	93131	HUB CAP	4
15	YBHH10105	BOLT HEX, 3/4 X 1/2 G5	16
16	YPEX16020	EXPANSION PIN, 1/2 X 4	4
17	YWLO10005	WASHER LOCK, 5/16	16
18	YBSD24010	BOLT STUD, 3/4 X 2-3/4	40
19	60N14	NUT HEX, FLANGE, 3/4 UNF-28 G8	40
20	59595	TANDEM AXLE, LH	1
21	90196	TIRE AND WHEEL ASSEMBLY, LH	2
22	90204	TIRE AND WHEEL ASSEMBLY, RH	2
23	FBC36	TIRE, 600/50 22.5 16PLY	1
24	90190	WHEEL, 22.5 X 20.0 10B	1
25	72437	VALVE STEM	1





H&S MFG. CO.

products approved

for the

FEMA

SEAL OF QUALITY



Manufactured by:

H&S MANUFACTURING CO., INC.

2608 S. HUME AVE. MARSHFIELD, WI 54449

(715) 387-3414 | hsmfgco.com

