

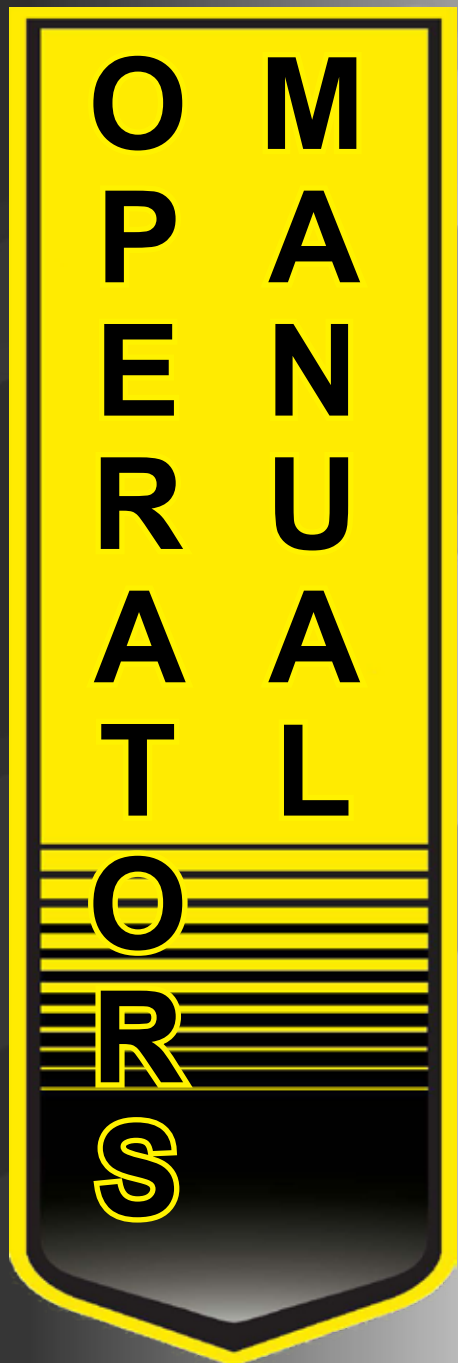

7223 / 7225 / 7227 FORAGE BOX



WARNING

READ AND UNDERSTAND THIS MANUAL BEFORE OPERATING THIS EQUIPMENT. UNSAFE OPERATION OR MAINTENANCE OF THIS EQUIPMENT CAN RESULT IN SERIOUS INJURY OR DEATH.

FB747223 Starting Serial #122SD23002

FB747225 Starting Serial #122SD25001

FB747227 Starting Serial #122SD27001 Part #86594

Rev. #01

HSMFG0421

STRONG HERITAGE - STRONG PEOPLE - STRONGER FUTURE

CONTENTS

Warranty	1
Manufacturer's Statement	2
Warranty Registration Form	3
Dealer Pre-Delivery Checklist	5
Dealer Delivery Checklist	7
Safety Information - Be Alert Symbol	9
Safety Information - Explanation of Safety Signs	10
Safety Decals	11-12
Safety Information - Warning - Owner Must Read and Understand	13
Safety Information - Warning - Emergency Stop	14
Cap Screw Torque Values	15
Set-Up & Assembly	16
Transporting	17
Preparing for Operation	18-19
Operation	20-22
Adjustments	23-25
Service	26-27
Optional Equipment	28
Lubrication Guide	29-31
Decal Location	32-37
Service Notes	38

H&S WARRANTY

H&S Manufacturing Co., Inc. ("H&S") warrants this product to be free from defect in material and workmanship. Except as noted below, this warranty term is twelve (12) months on labor, and twenty-four (24) months on parts from the date of delivery of the product to the original purchaser by an authorized H&S dealer. Under this warranty, H&S will repair or replace, at its option, any covered part which is found to be defective in material or workmanship during the applicable warranty term. In no case will the covered repair cost of a part or parts exceed the replacement cost of that part. Warranty service must be performed by H&S or a dealer authorized by H&S to sell and/or service the product involved, which will use only new or remanufactured parts or components furnished by H&S. This warranty includes approved parts and labor to fix the product but does not include, and the purchaser is responsible for, any service call and/or transportation of the product to and from the dealer's place of business, for any premium charged for overtime labor requested by the purchaser, and for any service work not directly related to any defect covered under this warranty. This warranty includes only those components of the product manufactured by H&S. Warranty for any component not manufactured by H&S including, but not limited to, engines, batteries, tires, rims, hydraulic motors, pumps, etc. are covered by the warranty, if any, provided separately by their respective manufacturers.

This warranty in all its parts, is extended solely to the original purchaser of the product, is terminated upon any subsequent transfer or sale from or by the original purchaser and extends no third party benefits or rights whatsoever.

The warranty term for any product used in any commercial, custom, for hire or rental application, is limited to six (6) months from the date of delivery of the product to the original purchaser or the first day of service, whichever comes first, by an authorized H&S dealer.

For commercial, custom for hire, or rental application, warranty is limited to 6 months from the date of delivery to the original purchaser, or the first day in service, whichever is earlier.

This warranty does not include: (1) Any product that has been altered or modified in ways not approved by H&S; (2) Depreciation or damage caused by normal wear, use for which the product was not designed, misuse, improper or insufficient maintenance, improper operation, accident or failure to follow the product Operator's Manual recommendations and product decal recommendations; (3) Normal maintenance parts and service; (4) Repairs made with parts other than those available from H&S or performed by anyone other than H&S or a dealer authorized by H&S to sell and/or service the product involved.

To secure warranty service the purchaser must report the product defect to a dealer authorized by H&S to sell and/or service the product involved within the applicable warranty term together with evidence of the warranty start date and make the product available to that dealer within a reasonable period of time.

THERE ARE NO WARRANTIES WHICH EXTEND BEYOND THE DESCRIPTION ON THE FACE OF THIS WARRANTY. H&S and the companies affiliated with it makes no warranties, representations, or promises, express or implied, as to the performance or freedom from defect of its products other than those set forth above and **NO IMPLIED WARRANTY OF MERCHANTABILITY, FITNESS OR FITNESS FOR A PARTICULAR PURPOSE IS MADE. IN NO EVENT WILL THE DEALER, H&S OR ANY COMPANY AFFILIATED WITH H&S BE LIABLE FOR INCIDENTAL OR CONSEQUENTIAL DAMAGES.** The **ONLY REMEDY** the purchaser has in connection with the breach of performance of any warranty on H&S products are those set forth above.

The selling dealer has no authority to make any representation or promise on behalf of H&S, or to modify the terms or limitations of this warranty in any way.

11/14/18

MANUFACTURER'S STATEMENT

Your New H&S Product has been manufactured of the finest quality materials and components. The performance you get from your machine is largely dependent upon how well you read and understand this manual and apply this knowledge. There is a right and a wrong way to do everything. Please do not assume that you know how to operate and maintain your Machine before reading this manual carefully. Keep this manual available for ready reference.

WARRANTY REGISTRATION

- ❖ Date of Purchase: _____
 - ❖ Purchaser Name: _____
 - ❖ Street Address: _____
 - ❖ City: _____
 - ❖ State: _____ Zip: _____
 - ❖ Phone Number: _____
 - E-mail Address: _____
 - ❖ Product: _____
 - ❖ Model Number: _____
 - ❖ Serial Number: _____
 - ❖ You have received the Operators Manual for this product. Yes _____ No _____
- Interested in receiving the H&S Newsletter? Yes _____ No _____
-

- ❖ Dealer Name: _____
- ❖ Street Address: _____
- ❖ City: _____
- ❖ State: _____ Zip: _____
- ❖ Signature: _____

❖ *All fields must be filled out to insure prompt notification of product and/or warranty updates.*

Please mail the completed WARRANTY REGISTRATION FORM to:
H&S Manufacturing Co., Inc.
2608 S. Hume Ave.
Marshfield, WI 54449

(Remove Copy At Perforation)

Intentionally Left Blank

DEALER PRE-DELIVERY CHECKLIST

AFTER COMPLETION, DEALER SHOULD REMOVE AND RETAIN FOR RECORDS

After the Forage Box has been completely set up, check to be certain it is in correct operating order before delivering to the customer. The following is a list of points to inspect. Check off each item as you have made the proper adjustments and found the item operating satisfactorily.

- Forage Box was not damaged in shipment. Check for dents and loose or missing parts. Report damage immediately to H&S Manufacturing Co., Inc.
- Forage Box has been correctly assembled according to instructions in this manual. Fasteners are tightly secured.
- All bolts and fasteners are tight.
- All shields and guards are in place and fastened.
- All grease fittings have been lubricated. Gearboxes are filled to proper levels if applicable. See Lubrication Chapter of this manual for details.
- Hoses and fittings if applicable, are properly attached and there are no visible leaks.
- All drive chains are adjusted to proper tension. See Adjustment Chapter of this manual.
- Decals are in place and legible.
- Connect the Forage Box to a tractor and attach the hydraulic hoses
- Connect the lights to the tractor. Lights and wiring functioning properly.
- Connect the control box to the electrical cord plug pigtail off of the 7-pin plug.
- Run the Forage Box and make sure all components operate properly.
- Hydraulic system does not leak under pressure.

Model Number _____

Serial Number _____

Dealer's Name _____

Inspection Date _____

Signature of Pre-Delivery Inspector _____

(Remove Dealer File Copy At Perforation)

Intentionally Left Blank

DEALER DELIVERY CHECKLIST

AFTER COMPLETION, DEALER SHOULD REMOVE AND RETAIN FOR RECORDS

This checklist that follows is an important reminder of valuable information that should be passed on to the customer at the time this Forage Box is delivered.

Check off each item as you explain it to the customer.

This delivery checklist, when properly filled out and signed assures the customer that the pre-delivery service was satisfactorily performed.

- Explain to the customer that the pre-delivery inspection was made.
- Explain to the customer all the safety precautions they must exercise when operating this unit.
- Explain recommended loads for different types of materials.
- Explain to customer that regular lubrication is required for proper operation and long life of machine.
- Show customer the lubrication section of Owner's Manual.
- Give the customer Owner's Manual and make sure they read and understand all operating and service instructions.
- Have customer sign a completed "Warranty Registration" and mail it promptly.

Date Delivered _____

Dealer's Name _____

By _____

Signature of Original Buyer _____

Note: Warranty is not valid until warranty card is completed and returned to H&S Mfg. Co., Inc.

Intentionally Left Blank

SAFETY INFORMATION



**BE
ALERT!**

**YOUR SAFETY
IS INVOLVED.**

THIS SYMBOL IS USED THROUGHOUT THIS BOOK WHENEVER YOUR PERSONAL SAFETY IS INVOLVED. TAKE TIME TO BE CAREFUL. REMEMBER: THE CAREFUL OPERATOR IS THE BEST OPERATOR. MOST ACCIDENTS ARE CAUSED BY HUMAN ERROR. CERTAIN PRECAUTIONS MUST BE OBSERVED TO PREVENT THE POSSIBILITY OF INJURY OR DAMAGE.

H&S MANUFACTURING CO., INC.

SAFETY INFORMATION

Keep signs in good condition. Immediately replace any missing or damaged signs.

RECOGNIZE SAFETY INFORMATION

This is the safety alert symbol. When you see this symbol on your machine or in this manual, be alert to the potential for personal injury.

Follow recommended precautions and safe operating practices.



UNDERSTAND SIGNAL WORDS

A signal word - DANGER, WARNING, or CAUTION - is used with the safety alert symbol. DANGER identifies the most serious hazards.

Safety signs with signal word DANGER or WARNING are typically near specific hazards.

General precautions are listed on CAUTION safety signs.



WARNING



CAUTION



FOLLOW SAFETY INSTRUCTIONS

Carefully read all safety messages in this manual, and all safety signs on your machine. Follow all recommended precautions and safe operating procedures.

OBSERVE MAXIMUM TRANSPORT SPEED

The maximum transport speed for this implement is 32 km/h (20 mph).

Some tractors are capable of operating at speeds that exceed the maximum transport speed of this implement. Regardless of the maximum speed capability of the tractor being used to tow this implement, do not exceed the implement's maximum transport speed.

Exceeding the implement's maximum transport speed can result in:

- * Loss of control of the tractor/implement combination
- * Reduced or no ability to stop during braking
- * Implement tire failure
- * Damage to the implement structure or its components

Use additional caution and reduce speed when towing under adverse surface conditions, when turning, and when on inclines.

Do not attempt transport if the fully loaded implement weighs more than 1.5 times the weight of the tractor.



SAFETY DECALS

⚠ WARNING

HELP AVOID INJURY

- READ & UNDERSTAND THE OPERATORS MANUAL PROVIDED WITH THIS MACHINE. IF MISPLACED CALL H & S MANUFACTURING AT 715-387-3414 WITH MODEL AND SERIAL NUMBER.
- UNDERSTAND ALL SAFETY WARNINGS AND FUNCTION OF CONTROLS.
- KEEP SAFETY DEVICES IN PLACE AND WORKING.
- KEEP YOURSELF AND OTHERS WELL CLEAR OF MOVING PARTS.
- DISCONNECT ALL POWER BEFORE SERVICING OR CLEANING THIS MACHINE.
- DO NOT EXCEED 20 MPH

72203A



⚠ WARNING

DO NOT GO NEAR LEAKS

- High pressure oil easily punctures skin causing serious injury, gangrene or death.
- If injured, seek emergency medical help. Immediate surgery is required to remove oil.
- Do not use finger or skin to check for leaks.
- Lower load or relieve hydraulic pressure before loosening fittings.

11599

⚠ WARNING

KEEP CHILDREN AWAY AT ALL TIMES!

2495



DO NOT REMOVE SHIELDS

MOVING PARTS INSIDE

1494K

⚠ DANGER

ROTATING DRIVELINE CONTACT CAN CAUSE DEATH KEEP AWAY!

DO NOT OPERATE WITHOUT-

- ALL DRIVELINE, TRACTOR AND EQUIPMENT SHIELDS IN PLACE.
- DRIVELINES SECURELY ATTACHED AT BOTH ENDS.
- DRIVELINE SHIELDS THAT TURN FREELY ON DRIVELINE.

1494L

⚠ WARNING

DO NOT CLEAN OR WORK ON THIS MACHINE WITHOUT FIRST DISENGAGING POWER AND SHUTTING OFF TRACTOR ENGINE.

1494J

⚠ WARNING

WHEN OPERATING FORAGE BOX AS A REAR UNLOAD, OPERATOR SHOULD REMAIN IN TRACTOR SEAT AND KEEP ALL OTHERS WELL CLEAR.

EMERGENCY STOP DOES NOT STOP FORAGE BOX WHEN BEING OPERATED AS A REAR UNLOAD.

1494Q

⚠ DANGER

MAINTAIN SAFE CLEARANCE FROM ELECTRICAL POWER LINES AND AVOID CONTACT WITH ANY ELECTRICALLY CHARGED CONDUCTOR.

CONTACT WITH ELECTRIC POWER SOURCES CAN RESULT IN ELECTRICAL SHOCK OR ELECTROCUTION.

FAILURE TO HEED THIS WARNING MAY RESULT IN SERIOUS INJURY OR DEATH.

1494P

⚠ WARNING

DO NOT REMOVE SHIELDS

MOVING PARTS INSIDE

1494B

SAFETY DECALS

	<p style="text-align: center;">! WARNING</p> <p style="text-align: center;">DO NOT OPERATE THIS EQUIPMENT IF THIS DECAL IS EXPOSED. REPLACE SAFETY SHIELDS.</p> <p style="text-align: right; font-size: small;">1494A</p>
---	---

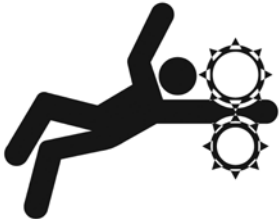
	<p style="text-align: center;">! DANGER</p> <p style="text-align: center;">NEVER ENTER FORAGE BOX UNLESS THE FOLLOWING SAFETY PRECAUTIONS ARE FOLLOWED.</p> <p style="text-align: right; font-size: small;">1494F</p>
---	---

	<p style="text-align: center;">! WARNING</p> <p style="text-align: center;">STAY CLEAR MOVING PARTS UNDER THIS AREA</p> <p style="text-align: right; font-size: small;">1494C</p>
---	---

	<p style="text-align: center;">! WARNING</p> <p style="text-align: center;">EMERGENCY STOP CABLE FUNCTIONS ONLY WHEN FORAGE BOX IS BEING OPERATED AS A FRONT UNLOAD</p> <p style="text-align: right; font-size: small;">14940</p>
---	---

<p>! DANGER</p>

<p style="text-align: center;">STAY CLEAR OF BEATER AND/OR CROSS CONVEYOR IF POWER SOURCE OR PTO IS RUNNING</p> <p style="text-align: center;">FAILURE TO HEED THIS WARNING MAY RESULT IN PERSONAL INJURY OR DEATH</p> <p style="text-align: center;">KEEP CLOTHING, YOURSELF AND OTHERS WELL CLEAR.</p> <p style="text-align: right; font-size: small;">1494H</p>

<p>! DANGER</p>

<p style="text-align: center;">KEEP OUT</p> <p style="text-align: center;">DISENGAGE ALL POWER AND SHUT OFF TRACTOR ENGINE BEFORE ATTEMPTING TO ENTER OR CLEAN FORAGE BOX.</p> <p style="text-align: center;">FAILURE TO HEED THIS WARNING MAY RESULT IN PERSONAL INJURY OR DEATH</p> <p style="text-align: right; font-size: small;">1494I</p>

<p>! WARNING</p>	<p>TO PREVENT SERIOUS INJURY OR DEATH NEVER OPERATE THIS UNIT UNLESS EMERGENCY STOP FUNCTIONS PROPERLY</p> <p style="text-align: right; font-size: x-small;">5896C</p>
-------------------------	---

SAFETY INFORMATION

TRACTOR:

This Operator's Manual uses the term "Tractor" when identifying the power source.



TO PREVENT SERIOUS INJURY OR DEATH, NEVER OPERATE THIS UNIT UNLESS EMERGENCY STOP FUNCTIONS PROPERLY.

BEFORE YOU ATTEMPT TO OPERATE THIS EQUIPMENT, READ AND STUDY THE FOLLOWING INFORMATION. IN ADDITION, MAKE SURE THAT EVERY INDIVIDUAL WHO OPERATES OR WORKS WITH THIS EQUIPMENT, WHETHER FAMILY MEMBER OR EMPLOYEE, IS FAMILIAR WITH THESE SAFETY PRECAUTIONS.

If the machine becomes clogged or for servicing, Stop the tractor engine, remove ignition key and allow all mechanisms to stop. Before cleaning or working on the machine completely disengage the tractor hydraulics.

DO NOT attempt to perform maintenance or repair with tractor running, electrical, and hydraulic hoses connected to the tractor.

DO NOT ALLOW PERSONNEL OTHER THAN THE QUALIFIED OPERATOR NEAR THE FORAGE BOX.

Be sure the Forage Box is clear of people, tools, and other objects before engaging the electrical controls.

DO NOT allow minors to operate or be near the Forage Box.

DO NOT step up on the Forage Box at any time while in operation.

NEVER start the Forage Box until all guards and safety shields are secured in place.

STAY CLEAR of discharge conveyor opening when in operation.

Keep hands, feet, and clothing away from all moving parts when the Forage Box is in operation.

Loose or floppy clothing should not be worn by the operator.

STAY CLEAR of hydraulic lines, they may be under extreme pressure or heat.

NEVER manually feed material into the beaters.

DO NOT clean, adjust, or lubricate the machine when any part is in operation.

CHECK frequently to be assured that the emergency stop mechanism is in proper operating condition.

CAUTION - Beware of low electrical wires.

STAY CLEAR of rear of forage box at all times.

H&S Mfg. Co. always takes the operator and their safety into consideration and guards exposed moving parts for their protection. However, some areas cannot be guarded or shielded in order to ensure proper operation. In addition, the Operator's Manual and decals on the Machine itself warn you of further danger and should be read and observed closely.

Study The Above Safety Rules
ATTENTION - BE ALERT - YOUR SAFETY IS INVOLVED

SAFETY INFORMATION



WARNING

**TO PREVENT SERIOUS INJURY OR DEATH, NEVER OPERATE THIS UNIT
UNLESS THE EMERGENCY STOP FUNCTIONS PROPERLY**

EMERGENCY STOP

1. In case of an emergency, pushing the emergency stop panel rearward, or pulling the trip cables will stop the cross conveyor, beaters, and main apron.
2. Keep excessive slack out of the trip cables.
3. Trip the emergency stop occasionally, and when starting the unit after periods of storage to ensure proper function.
4. To reset, turn the control box switch back to the OFF/RESET position, then rotate the switch back to one the unloading positions.

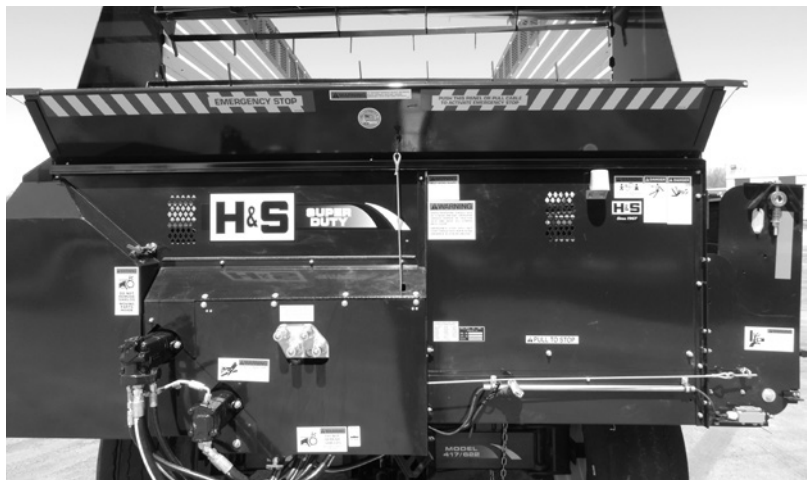

CAP SCREW TORQUE VALUES

The specifications below are the torque values for fasteners as it adheres to the SAE torque value standards. All fasteners should be torqued to the proper values found in the figures below unless otherwise specified by the engineering drawing.

Lubed torque would be any fastener that has grease, liquid Loctite, oil, etc. on the threads.

Dry torque would be any fastener which has threads that are clean and dry and do not have any liquid Loctite or grease on them.

Hex Head Fasteners

The figure shown below shows how to determine what grade a fastener is.

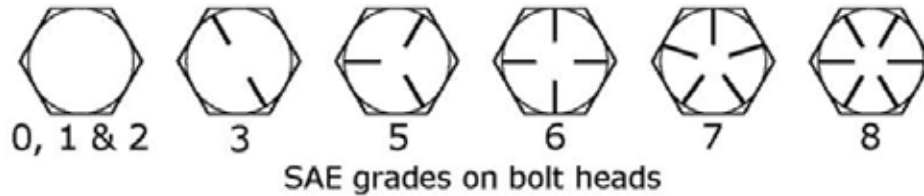

	SUGGESTED ASSEMBLY TORQUE VALUES						WORKING TORQUE			
	SAE GRADE 2 -6"		SAE GRADE 5		SAE GRADE 8		18-8 SS	316 SS	BRASS	SILICON BRONZE
Diam & Thrds Per Inch	Dry FT. LB.	LUB FT. LB.	Dry FT. LB.	LUB FT. LB.	Dry FT.LB.	LUB FT. LB.	IN LBS	IN LBS	IN LBS	IN LBS
1/4-20	5.5	4.2	8	6.3	12	9	75.2	78.8	61.5	68.6
1/4-28	6.3	4.7	10	7.2	14	10	94.0	99.0	77.0	87.0
5/16-18	11	8	17	13	24	18	132	138	107	123
5/16-24	12	9	19	14	27	20	142	147	116	131
3/8-16	20	15	30	23	45	35	236	247	192	219
3/8-24	23	17	35	25	50	35	259	271	212	240
7/16-14	32	24	50	35	70	50	376	393	317	349
7/16-20	36	27	55	40	80	60	400	418	327	371
1/2-13	50	35	75	55	110	80	517	542	422	480
1/2-20	55	40	85	65	120	90	541	565	443	502
9/16-12	70	55	110	80	150	110	682	713	558	632
9/16-18	80	60	120	90	170	130	752	787	615	697
5/8-11	100	75	150	110	210	160	1110	1160	907	1030
5/8-18	110	85	170	130	240	180	1244	1301	1016	1154
3/4-10	175	130	260	200	380	280	1530	1582	1249	1416
3/4-16	200	140	300	220	420	310	1490	1558	1220	1382
7/8-9	170	125	430	320	600	450	2328	2430	1905	2140
7/8-14	180	140	470	350	670	500	2318	2420	1895	2130
1-8	250	190	640	480	910	680	3440	3595	2815	3185
1-14	280	210	720	540	1020	760	3110	3250	2545	2885

SET-UP & ASSEMBLY



WARNING: Some photographs used in the following pages show guards or shields removed for clarification. Never operate machine until these guards or shields are in proper operating position.

NOTE: Determine right or left side of the Machine by viewing it from the rear. If instructions or parts lists call for hardened bolts, refer to Cap Screw Torque Values chart.

1. Check the Forage Box for proper assembly and adjustment. Make sure that all bolts are tightened.
2. Properly lubricate the Forage Box before operating. Refer to Lubrication Section of this Operator's Manual for locations.
3. Check all lights to make sure that they are functioning properly.

TRANSPORTING

TRANSPORT LIGHTING & REFLECTORS

Transport lighting is standard on all Super Duty Models. The lighting system is to be connected to the 7-pin power receptacle (per SAEJ560B) on your tractor. If your tractor is not equipped with the proper receptacle, see your tractor dealer for details. Red reflective safety decals are on the rear of the box for safety.



WHEN TRANSPORTING ON THE HIGHWAY OR ROADS, PLACE THE SMV SIGN IN THE SOCKET PROVIDED AND REGULARLY CLEAN THE REFLECTIVE TAPE AT THE REAR OF THE FORAGE BOX.

NOTE: Obey all state and local laws concerning towed equipment on public roads.

TOWING ON HIGHWAY

To view beyond the back of the Forage Box when transporting the unit on a public highway, consider obtaining and installing a rearview mirror on your tractor with a wide load mounting bracket.

PREPARING FOR OPERATION

Check over the entire unit carefully before first operation. Tighten bolts, set screws, and chains which may have come loose in handling. Lubricate as explained in the Lubrication Guide. Successful operation will be achieved by periodic adjustments and experience of the operator. Make sure to read & understand the feeder apron adjustments.

TRACTION CONNECTIONS

1. Attach the quick coupler hydraulic hoses to the 2-remote ports on the right-hand side as you look at the forage box. They are the remotes for the front unload system. Attach the other hose ends to the remotes on the tractor.

2. Connect the electrical plug for the control box to the tractor convenience plug or hard wire it to the battery with the supplied pig tails.

3. Connect the Forage Box 7-pin lighting electrical plug to the tractor 7-pin plug.

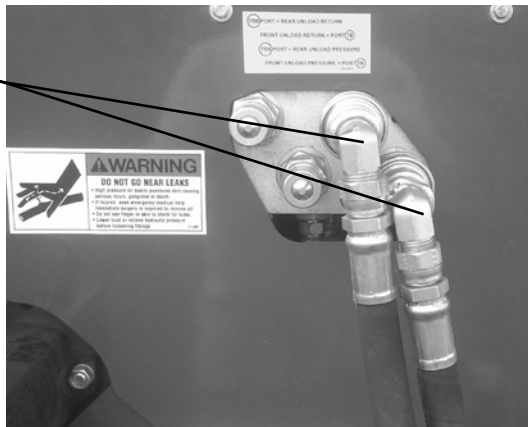

OPERATION OF FRONT UNLOAD SYSTEM

1. Push the POWER switch to the ON position.

2. Push the APRON SPEED switch to the LOW speed position.

3. Engage the tractor remote hydraulic lever to the DETENT position.

4. Turn the FUNCTION Control Dial from the OFF/RESET position to the EXTEND position. This will fold down the cross conveyor extension and make contact with the micro switch. When contact is made, the remaining functions of the Control Box will be operational.

5. Run the front unloading mechanism through all the functions for several minutes, switching to the HIGH apron speed position. This will serve as a break-in and as a check that all parts are assembled and lubricated properly.

6. When the break-in is complete, turn the Control Dial to the RETRACT position. This will fold the cross conveyor extension up for transporting the Forage Box. When the cross conveyor extension has been retracted, turn the Control Dial to the OFF/RESET position.

7. When you have finished running the Forage Box, and have followed the EMERGENCY SHUTDOWN PROCEDURE, check the main apron chains again for proper adjustment, as paint may initially come off the apron chains and chains may loosen. The main apron chains must be taken up evenly before you use the forage box. Check again after the first few loads. The main aprons should be at proper tension at all times. See Adjustment Section for details.

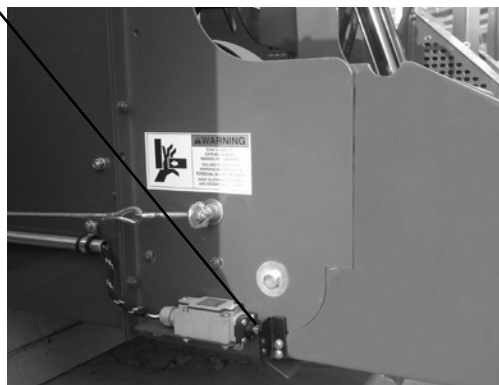

PREPARING FOR OPERATION

OPERATION OF REAR UNLOAD SYSTEM

1. After the front unload system has been run, disconnect the quick couplers from the right side Forage Box remotes and connect them to the left side remote ports. This is for the rear unload system.

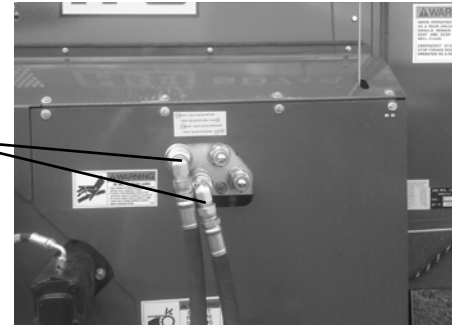

2. Remove the clip pin holding the drive pin in front drive sprocket assembly. Rotate the pin counter-clockwise and remove it from the assembly.

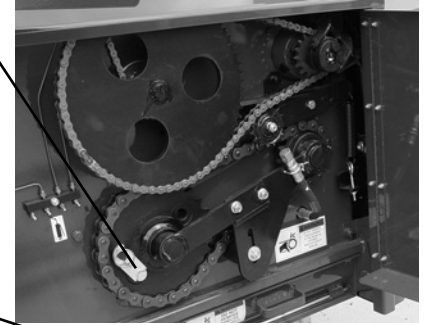

3. Re-insert the drive pin into rear drive sprocket and rotate the pin clockwise until it locks into groove on peg. Secure with the clip pin.

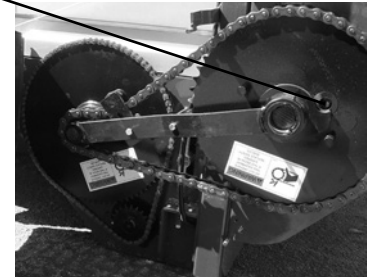

4. Unlock the rear door locks located on the inside of the left and right hand rear drive shaft brackets. These latches lock against knurled gears on rear drive shaft to hold the door closed when operating the forage box as a rear unload. When the tractor hydraulics are activated and the rear drive shaft turns, the knurled gears flip the latches open to allow the rear door to swing free. Upon completion of unloading, check the rear door to ensure that latches are securely in place for the next load.

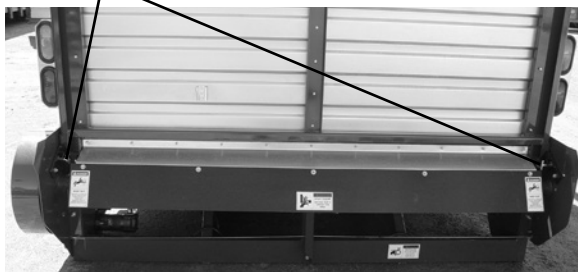

Replace and properly secure all safety shields after making change.

CAUTION: Rear door locks should be locked in position only when using the front unload. While operating the rear unload, the rear door locks **MUST** remain unlocked.

5. The rear chain tightener should have a slight deflection at the center of the chain. See the Adjustment Section for details.

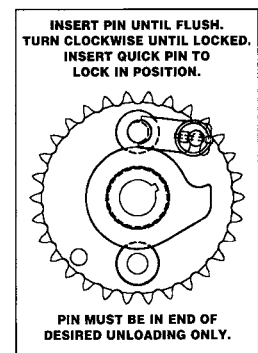

FAILURE TO UNLOCK REAR DOOR LOCKS WHEN BOX IS BEING UNLOADED TO THE REAR WILL RESULT IN SEVERE DAMAGE TO THE FORAGE BOX.

OPERATION

GENERAL INFORMATION

Check the entire Forage Box carefully before first operation. Tighten the bolts and set screws that might have come loose in transporting. Lubricate if needed as explained in the Lubrication Chapter in this manual.

EMERGENCY SHUTDOWN

In case of an emergency, pushing the emergency stop panel, emergency stop bar, or pulling the safety cable will stop cross conveyor, beaters, and main aprons. PTO will continue to rotate. If the Forage Box is plugged with material or a foreign object becomes lodged in the discharge area, disengage the PTO. Stop the tractor engine, remove ignition key, and allow all mechanisms to stop before cleaning or working on the machine. Trip emergency stop occasionally to ensure proper function.

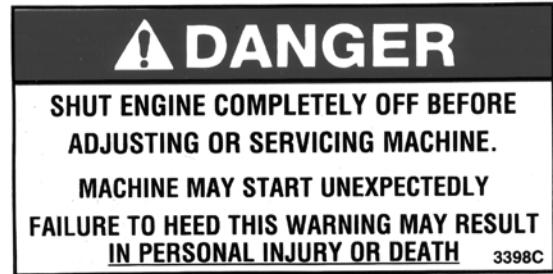

Emergency Stop Panel

Emergency Stop Cable

CONTROLS & SAFETY EQUIPMENT

Forage Boxes are provided with several features for operator safety and convenience.

Guards & Shields

Whenever possible and without affecting the operation of the Super Duty, guards, shields and/or hinged shields have been used on this equipment to protect potentially hazardous areas. In many places, decals are also provided to warn of potential dangers as well as to display special operation procedures.



OPERATION

UNLOADING - FRONT UNLOAD

1. Park the forage box on level ground whenever possible during unloading. Lock the tractor parking brake.
2. Make sure that all the hydraulic and electrical connections have been made as stated in the PREPARING FOR OPERATION SECTION.

3. Push the POWER Switch to the ON position
4. Push the APRON SPEED Switch to the LOW speed position.
5. Engage the tractor remote hydraulic lever to the DETENT position.



6. Turn the FUNCTION Control Dial from the OFF/RESET position to the EXTEND position. This will fold down the cross conveyor extension and make contact with the micro switch. When contact is made, the remaining functions of the Control Box will be operational.

7. If the cross conveyor is loaded with material, turn the Control Dial back and forth from CROSS CONVEYOR/ON, to EXTEND. This will discharge the material slowly and not overload the blower or bagger.

8. When the cross conveyor is clear of material, turn the Control Dial back and forth from BEATER/ON to CROSS CONVEYOR/ON. This will allow the beaters to clear material a little at a time to avoid exceeding blower/bagger capacity.



CAUTION: DO NOT ENGAGE BEATERS OR MAIN APRONS WHEN CROSS CONVEYOR IS FULL OF MATERIAL OR DAMAGE TO FORAGE BOX WILL RESULT.

9. When the beaters are clear of material, turn the Control Dial to the APRON/ON position. The variable speed drive offers you a number of unloading speeds to choose from. Rotating the SPEED CONTROL Dial will increase or decrease the main apron speed. If unloading speed is too slow, push the APRON SPEED Switch to the HIGH position and adjust the SPEED CONTROL Dial. With experience and depending on the type of forage, you will be able to select a speed which will match your blower/bagger capacity. Unloading speed may also be varied by increasing or decreasing engine speed of the tractor or truck.

10. If it is necessary to trip the stop mechanism and disengage the forage box drive before the box is empty, restart unloading by turning the FUNCTION Control Dial to the OFF/RESET position, and begin the unloading steps again.

11. When the forage box is empty, move the FUNCTION Control Dial to the RETRACT position. After the Cross Conveyor Extension has retracted, move the FUNCTION Control Dial to the OFF/RESET position, and push the POWER Switch to OFF.

OPERATION

FIELD OPERATION OF FRONT/REAR UNLOAD FORAGE BOX

1. Park the forage box on level ground whenever possible during unloading.
2. Make sure that the drive pin has been changed from front to rear unload as stated in the PREPARING FOR OPERATION - Rear Unload Section.
3. **CAUTION:** Rear door locks must be in unlocked position when set up as rear model as stated in the PREPARING FOR OPERATION - Rear Unload Section.
4. Connect the quick coupler hydraulic hoses on the Forage Box to the LEFT side ports for rear unload as shown. Connect the hydraulic hose tips of the hydraulic hoses to the tractor.
5. With the operator in the tractor seat and all others well clear of forage box, engage the tractor hydraulics to start unloading.
Note: The rear unload operates in only one direction. If the tractor hydraulic system stalls, reverse the lever on the tractor or switch the hydraulic hoses at the port on the tractor.
6. During unloading, move the Forage Box forward to allow material to fall way from rear of box.
7. The Hydraulic Gate Delay on the rear door will free float wide open, but after the material is unloaded, the rear door will stay open about 2' to allow the last little bit of forage to be discharged. When the Forage Box is empty, disengage tractor hydraulics. This will allow the Hydraulic Gate Delay pressure to release and the door will automatically close. Operation is the same as above if the box is mounted on a truck.
8. Check the rear door to make sure it is securely latched.



ADJUSTMENTS

OVERLOAD PROTECTION

Overload protection is achieved on the EH Control Forage Box by a pressure relief valve. Stop all operation and follow the EMERGENCY SHUTDOWN PROCEDURE. Always determine the cause of failure.

BEATER CLUTCH ADJUSTMENT

Check the beater clutch periodically to ensure beaters are being completely engaged or disengaged. Beater engage/disengage clutch is properly adjusted when there is 1/8" of clearance between clutch jaw and engaging jaw when control is in the disengage position.

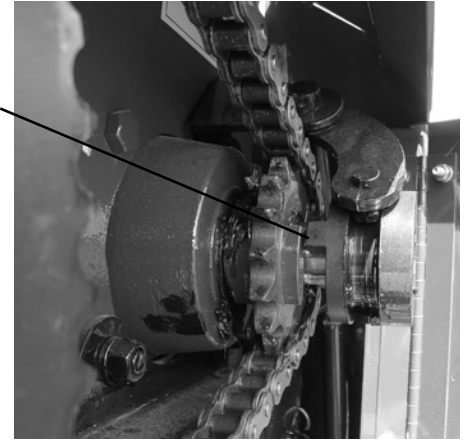

Basic adjustment can be made by positioning adjusting nut 3 3/4" from end of shifting rod.

Place the control arm tight against the nut. Adjust the mounting bracket in the slotted holes on the unit until 1/8" clearance is reached.

Fine adjustment is made by adjusting nut on shifting rod.

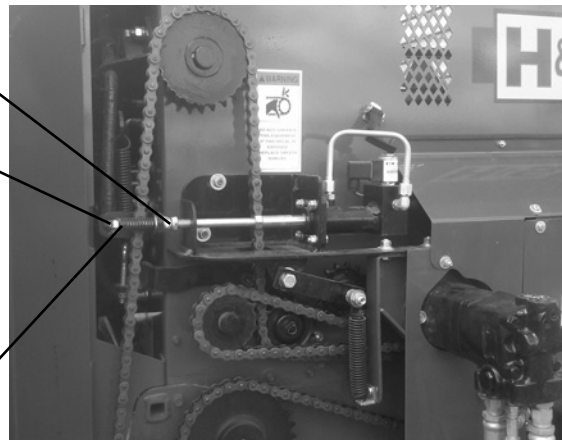

BEATER DRIVE CHAIN ADJUSTMENT

The beater drive chains have self adjusting spring tighteners on them. The gearbox to the 1st beater and primary drive chain are tightened with a common spring, maintain a 1/16" gap between the coils by adjusting the I-Bolt. DO NOT OVERTIGHTEN OR IT WILL CAUSE THE BEATERS TO TURN FROM THE TIGHTNESS OF THE CHAIN. The 2nd and 3rd beater springs should have a 1/16" gap between the coils. When the gap is less, check the condition of the chains, replace or remove link, offset link, or replace spring.

ADJUSTMENTS

DRIVE CHAIN IDLERS

Drive Chain Idler - Front Unload

A round poly chain tightener is provided to adjust tension on the roller chain between the gearbox and drive sprocket and main apron drive shaft. Chain is properly adjusted when there is slight deflection at the center of the chain, then tighten so it will not turn.

NOTE: *If an idler fails to maintain proper tension, replace the worn chain.*

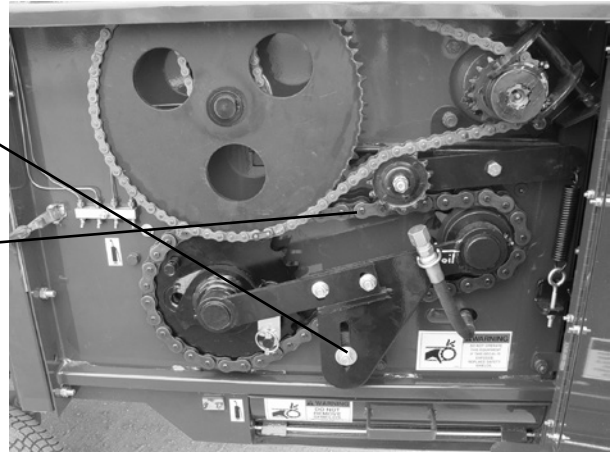

Drive Chain Idlers - Rear Unload

The roller chain between hydraulic motor and large reduction sprocket is adjusted by loosening the bolts holding motor. Slide motor downward in slots in panel until chain is tight. Retighten the bolts holding motor.

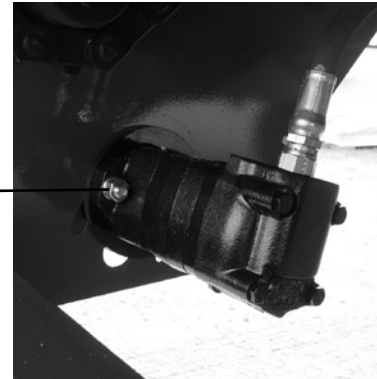

A roller type chain tightener is provided to adjust tension on roller chain between drive sprocket and main apron drive shaft. Chain is properly adjusted when there is a slight deflection at the center of the chain.

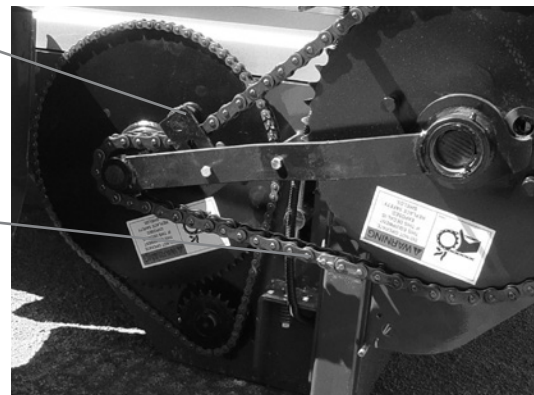

ADJUSTMENTS

CROSS CONVEYOR ADJUSTMENT

Proper tension should be maintained on cross conveyor chain during operation. To adjust the cross conveyor spring loaded tightener bolts, move the adjusting nuts on tightener bolts until proper tension on chain is reached. The chain is properly adjusted when the compression spring overall length is 1-1/2". Adjust both sides equally when the cross conveyor extension is down in the working position.

NOTE: Make sure that the cross conveyor extension is in the UNLOAD position when making adjustments.



MAIN APRON ADJUSTMENT - REAR UNLOAD

Four main feeder apron adjustment bolts are located at the rear of the Forage Box. Two are located at the center of the box and are accessible from below the frame. The left-hand tightener bolt is located in the panel behind drive shield at the left-hand rear corner of the box. The right-hand tightener bolt is located in the panel at the right rear corner of the box.

All apron chains must be taken up evenly before you use the Forage Box. Check again after the first few loads. The main feeder aprons should be at proper tension at all times. Tighten the full thread bolts to adjust the aprons. The aprons are properly adjusted when the compression springs are an overall length of one and one-half inches (1 1/2"). Maintain this tension when operating the box.

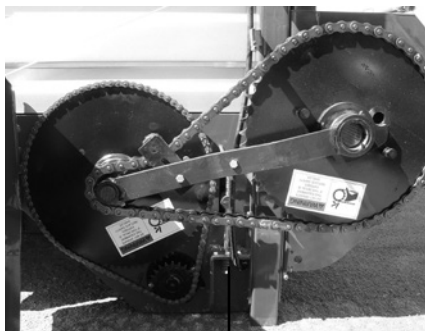

Rear Left-Hand
Tightener Bolt



Rear Center Main
Apron Tightener Bolts



Rear Right-Hand
Tightener Bolt

SERVICE

ENTERING FORAGE BOX

Front Unload

If you plan to manually unload the Forage Box utilizing cross conveyor, the following two-man procedure must be followed. **NEVER ATTEMPT THIS PROCEDURE ALONE. THE PERSON OUTSIDE OF FORAGE BOX OPERATING CONTROLS MUST NOT LEAVE CONTROLS.**

1. Disengage the tractor hydraulics, shut off the tractor, and remove the ignition key.
2. Remove the connector link from the beater drive roller chain and remove the chain from the sprockets. **CAUTION: BEATERS ARE NOW FREE TO ROTATE.**
3. Using a short piece of chain with hooks, secure the top beater to the center beater. See picture below.
4. Wrap the chain around the bar of the third beater and the top bar of second beater. Secure the chain together as tight as possible to eliminate the beaters from rotating in either direction. Keep the excess chain out of the cross conveyor chamber. **NOTE:** Hook the chain properly and securely to prevent unhooking during this procedure.
5. Using extreme caution, the first person may now climb over the beaters.
6. When the first person is clear of the beaters, the second person may start the tractor, engage the hydraulic lever, and turn the FUNCTION Control Dial to the CROSS CONVEYOR to operate.
7. Before the first person attempts to leave forage box, the second person must turn the FUNCTION Control Dial to OFF/RESET, disengage the tractor hydraulic lever, shut off the tractor, and remove the ignition key.
8. When the forage box is clear of people, remove the safety chain from the beaters, and reinstall the beater drive chain.



SERVICE

ENTERING FORAGE BOX

Rear Unload

When the Forage Box is empty, entry can be made through the rear door. Use the following steps when entering the Forage Box through the rear door.

1. Shut off tractor and remove ignition key.
2. Disconnect hydraulic hoses from tractor.
3. Securely block the rear door open to prevent accidental closure or entrapment.
4. Use a small ladder or similar climbing device to enter the rear of Forage Box.

When the Forage Box is not empty, and entry must be obtained, follow the Front Unload Entry Procedure.

CROSS CONVEYOR CLEAN-OUT PAN

1. Shut off tractor and remove ignition key.
2. Remove the clip pin from the end of the rod, and pull the rod out.
3. Grasp the handle of the pan and pull the pan out.
4. Remove any material in the conveyor area.
5. Reinstall pan, rod and clip pin.

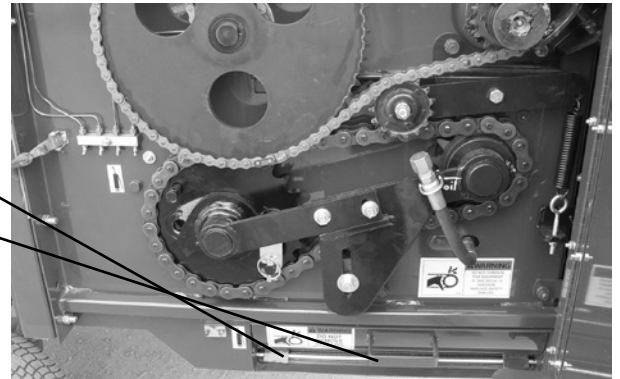

OPTIONS

4th BEATER

A 4th Beater Option is available.



LUBRICATION

GENERAL INFORMATION

IMPORTANT: *Catch and dispose of fluid per local waste disposal regulations whenever service is performed on hydraulic components, valves, cylinders, hoses, etc.*

GEARBOXES

Main Apron Drive Gearbox: Keep the main apron gearbox filled to the oil level plug in cover of gearbox using 85W140 lubricant.

Beater Drive Gearbox: Keep the beater drive gearbox filled to the center of the shafts. Use 80w-90 lubricant.

DRIVE CHAINS

Lubricate the drive chains with a light machine oil. Keep chains aligned with sprockets; this lengthens the life of the sprockets and chain. Lubricate chains often.

GREASING

There are numerous grease fittings on the Forage Box. Become familiar with all lubrication points and establish a routine to ensure complete lubrication of the Forage Box. Lubricating properly and often (every 10 hours) with a high-quality grease will prolong the life of the forage box. Replace any missing or plugged grease fittings. Wipe dirt from the fittings before greasing to prevent the dirt from being forced into the bearing or pivot. Grease should come out around the shaft on sleeve-type bearings. On the sealed ball bearings, grease should be added slowly until a slight bead forms at the seal indicating the correct amount of lubricant. To minimize dirt build-up, avoid excessive greasing. After greasing, wipe off the excess grease from around the outside of the bearings to prevent the accumulation of chaff and grit.

1. (1) one on beater drive clutch.
2. (1) one on beater drive sprocket.
3. (1) one on beater engage bronze yoke.
4. (2) one at each end of brace - gearbox to main apron drive shaft.
5. (2) remote fittings for right hand and center main apron drive shaft bushings.
6. (5) remote fitting - beater bearing (3 right side 2 left side) (sealed bearings - DO NOT over-grease).
7. (1) one on left hand main apron drive shaft bushing. (access through discharge opening)
8. (4) one on each main apron rear idler sprocket. (4 front unload) (8) front and rear unload)
9. (1) one on drive shaft end of brace for rear main apron drive shaft.
10. (1) one on gear reduction sprocket at rear of forage box.
11. (3) one on left, center and right hand rear drive shaft brackets.
12. (1) bottom beater left hand bearing.
13. (2) remote fittings for optional 4th beater.

LUBRICATION

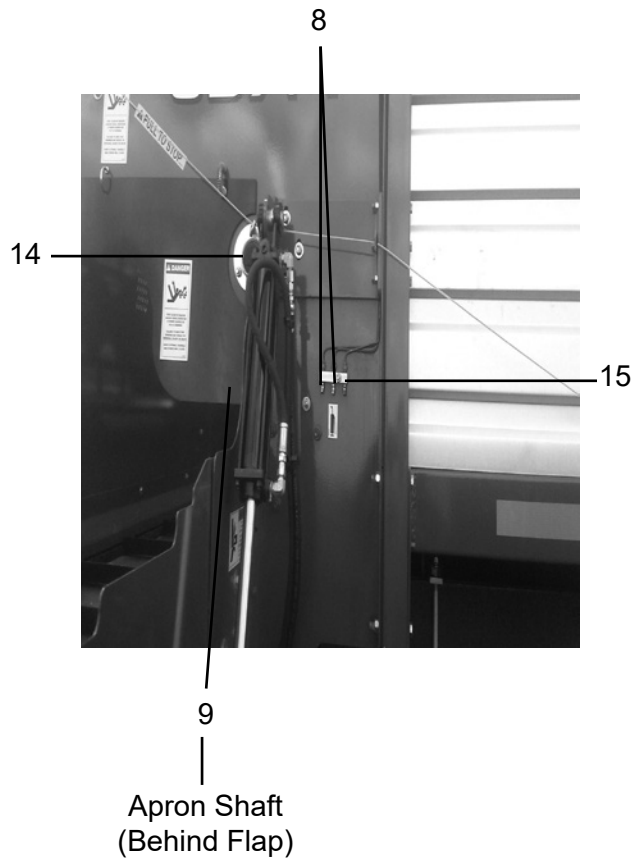
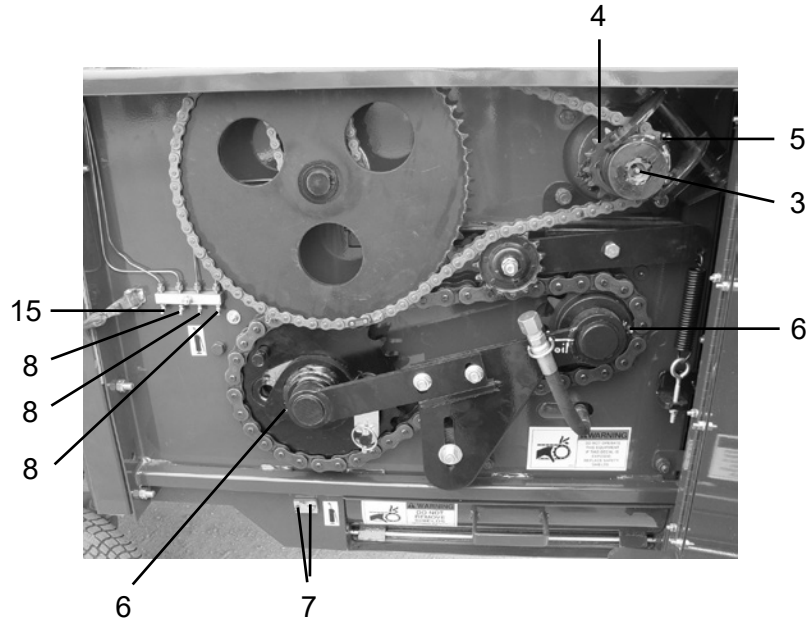

LUBRICATION



- (4) One on each **MAIN** apron shaft rear sprocket
- (4) One on each sprocket of the **LOWER** idler shaft
- (4) One on each sprocket of the **UPPER** idler shaft
- (2) on each of the rear door lock handles

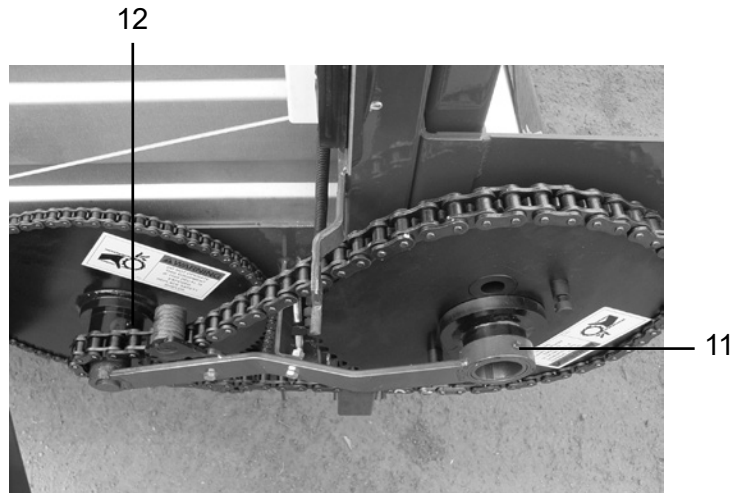

DECAL LOCATION

Your H&S Forage Box was manufactured with operator safety in mind. Located on the Forage Box are various decals to aid in operation and to warn of danger or caution areas. Pay close attention to all the decals on your Forage Box.



**DO NOT REMOVE ANY OF THESE DECALS. IF DECALS ARE LOST, DAMAGED, OR IF YOUR SUPER DUTY IS REPAINTED, REPLACE DECALS.
REMEMBER: DECALS ARE FOR YOUR PROTECTION AND SAFETY.**

Listed below are the decals on your Forage Box. These decals may be ordered individually by part number.

<u>Part #</u>	<u>Quantity</u>	<u>Description</u>
311	1	Patent Decal
1494A	7	Do not operate this machine if this decal is exposed. Replace safety shields.
1494B	5	Do not remove shields - moving parts inside.
1494C	7	Stay Clear - Moving parts under this area.
1494F	1	Never enter forage box unless the safety chain precautions are followed.
1494H	3	Stay Clear of beater and/or cross conveyor if power source or PTO is running.
1494I	2	Disengage all power and shut off tractor engine.
1494J	1	Do not clean or work on the machine without first disengaging power.
1494K	2	Do not remove shields - moving parts inside.
1494O	3	Emergency stop cable functions only when forage box is being operated as a Front Unload.
1494P	1	Maintain safe clearance from electrical power lines.
1494Q	1	When operating forage box as a rear unload, operator should remain in tractor seat and keep all others well clear of forage box.
2495	1	Keep Children Away
5896C	1	To prevent serious injury or death
8506	1	RH Yellow Strip
8510	1	LH Yellow Strip
11599	2	Do not go near leaks
31300	1	Insert Pin Until Flush
33326	1	H&S/Super Duty Name Decal (Front)
33331	2	7+4 Super Duty Decal (Side)
53102	2	Rear Door Lock
54033	1	3" Made in USA
82912	2	Do not operate this equipment if this decal is exposed. Replace safety shields
92412	1	Help avoid injury - Read and understand the operators manual
92706	2	Warning - Stay Clear of Extension
093020	3	Grease zerk decal
093366	1	Operators Manual
103-3185	1	Emergency Stop Decal
104-3185	1	Push this Panel
120-2177	3	Push to Stop
7+4 2191	1	Clean Out
7+4 3185G	1	Entering Forage Box
DCAMB	7	Amber Reflector
DCRED	2	Red Reflector
DC72011	1	TRB - Port = Rear Unload Return TB - Port = Front Unload Return TRA - Port = Rear Unload Pressure TA - Port = Front Unload Pressure

DECAL LOCATION

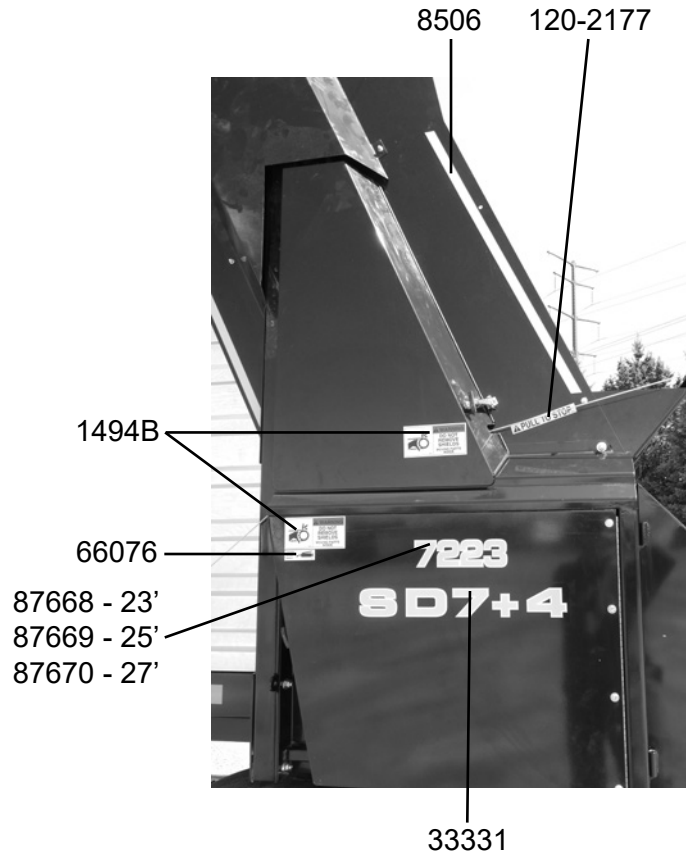
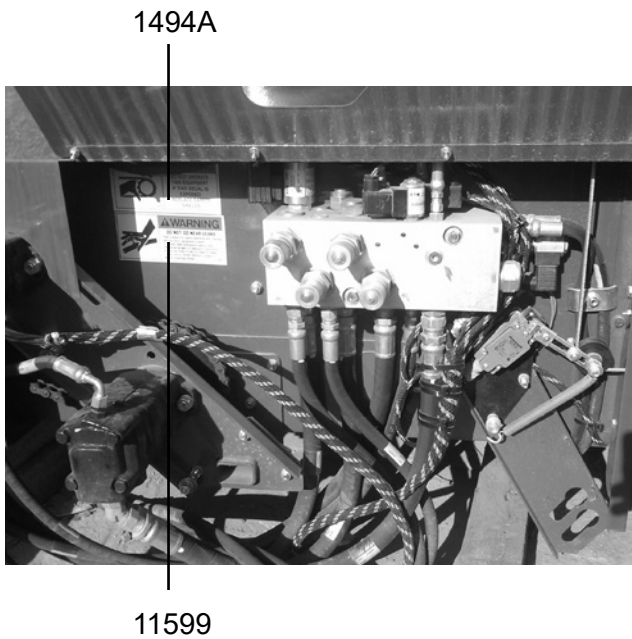
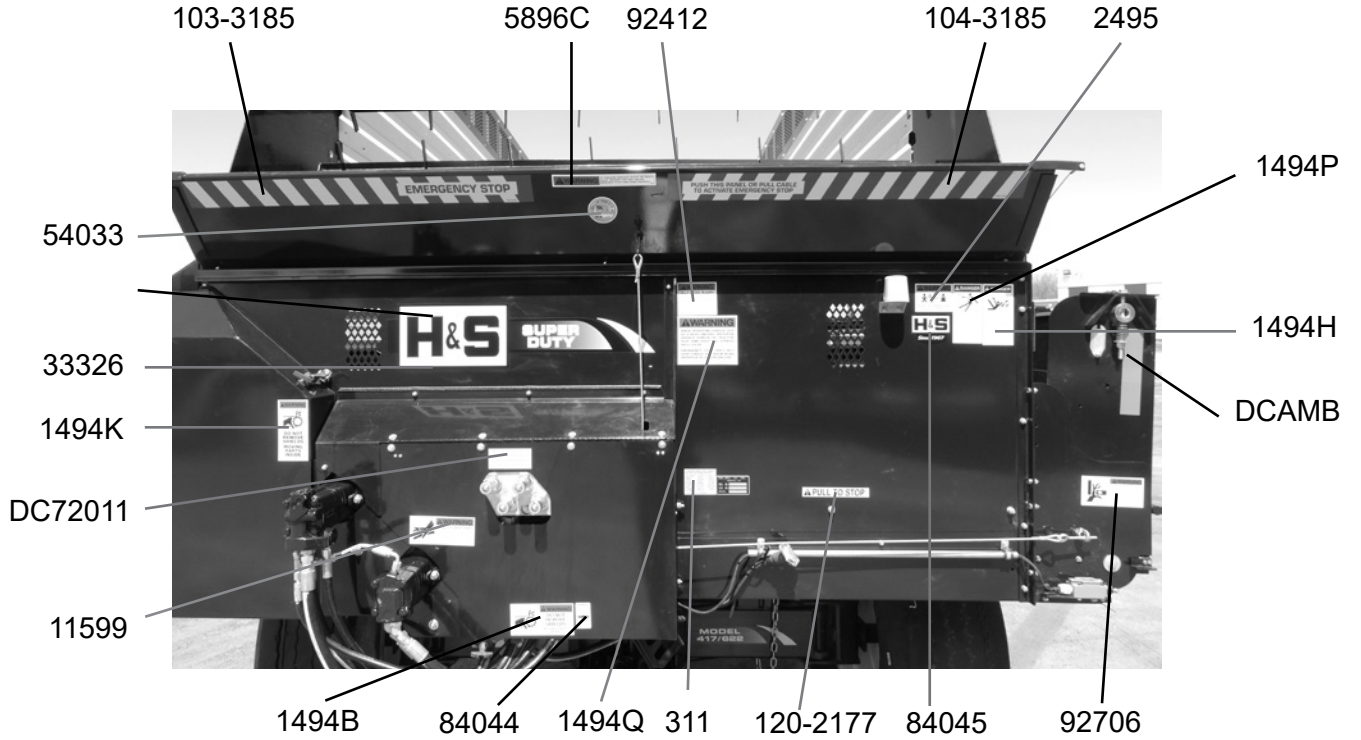

DECAL LOCATION

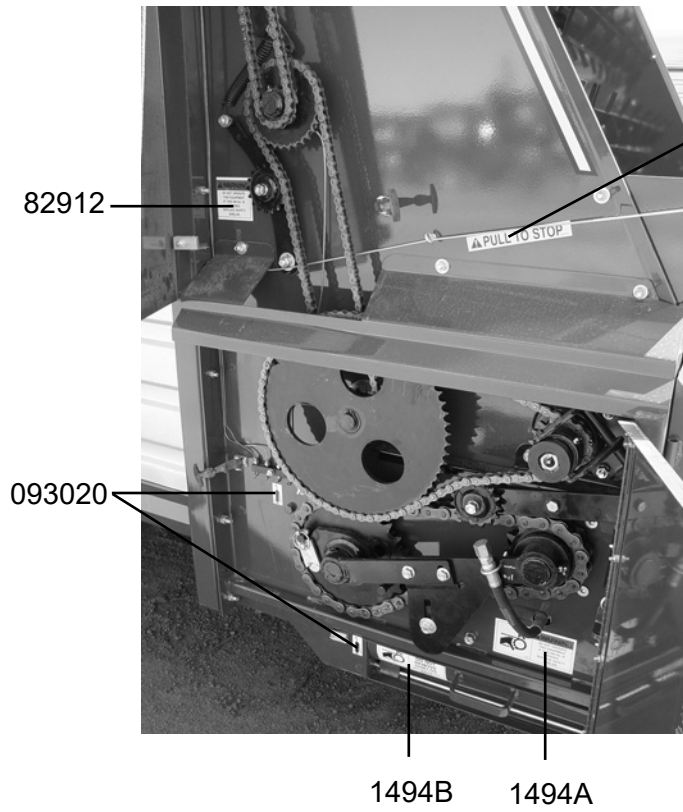

8506

120-2177

1494F

093366



DCRED

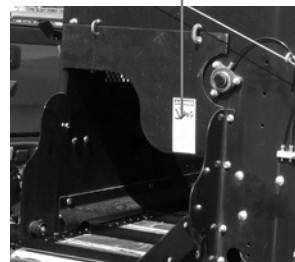
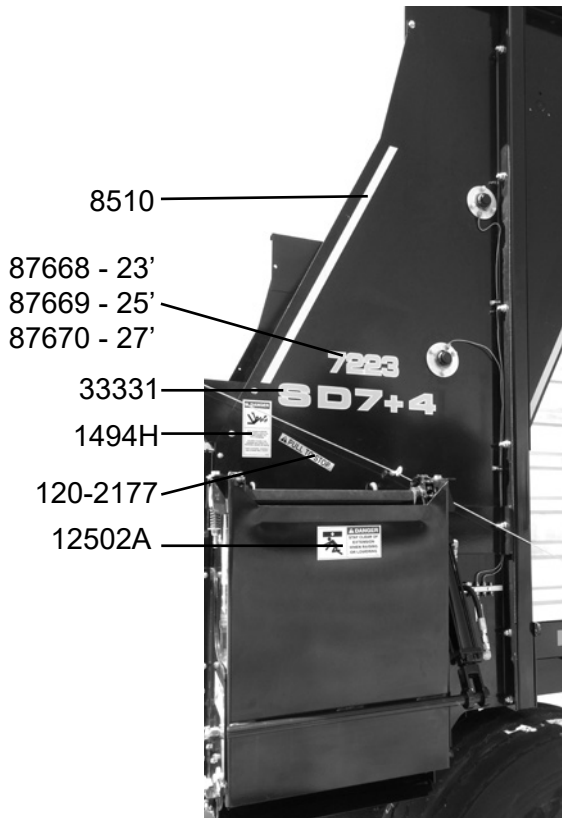

DECAL LOCATION



DECAL LOCATION - REAR UNLOAD

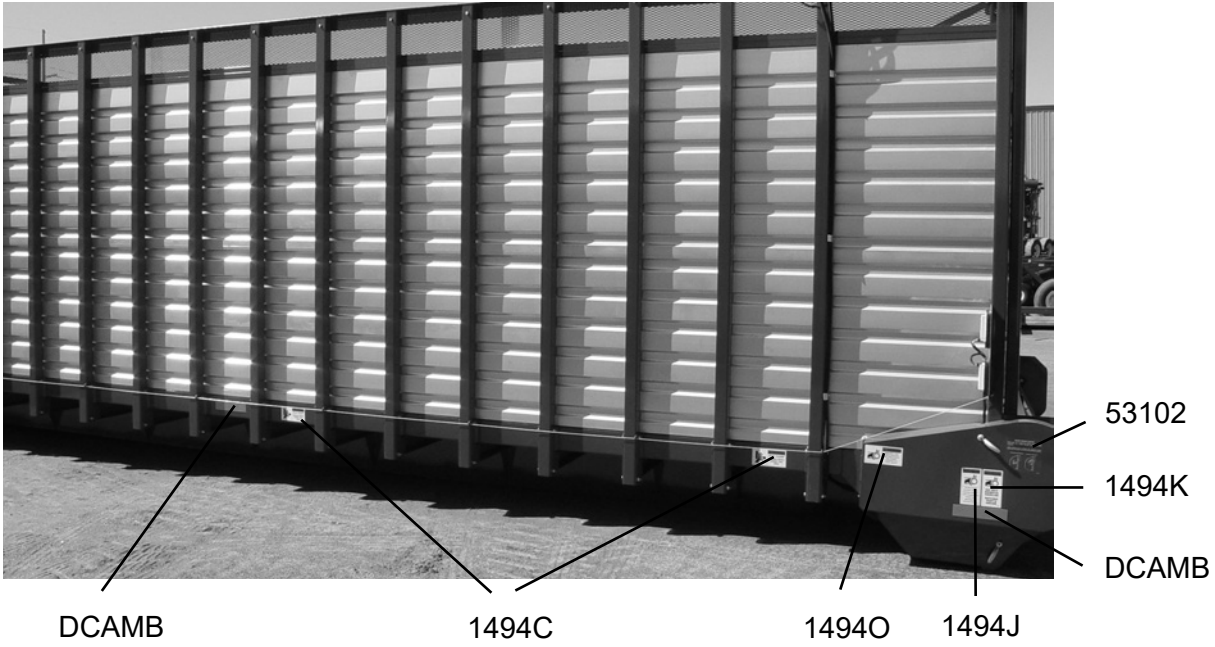

DECAL LOCATION - REAR UNLOAD

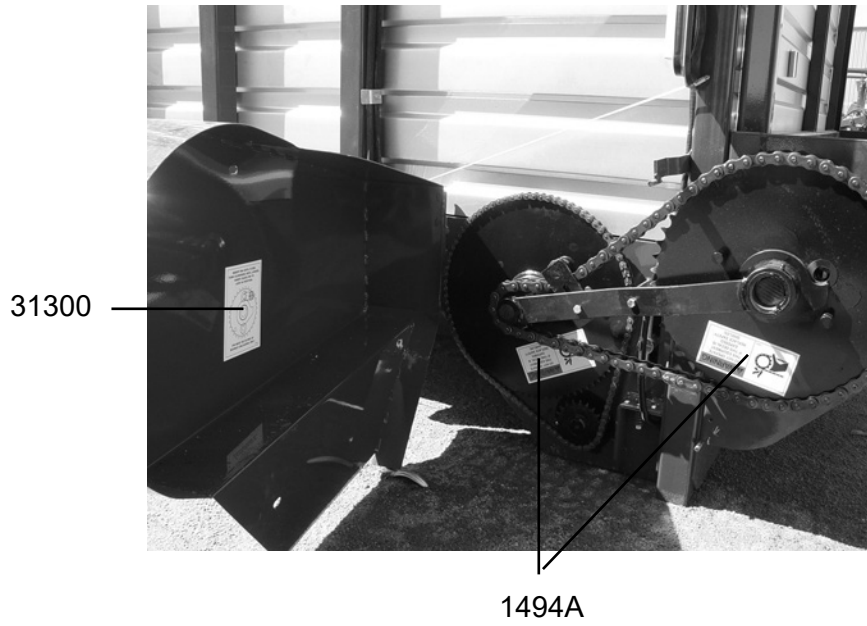
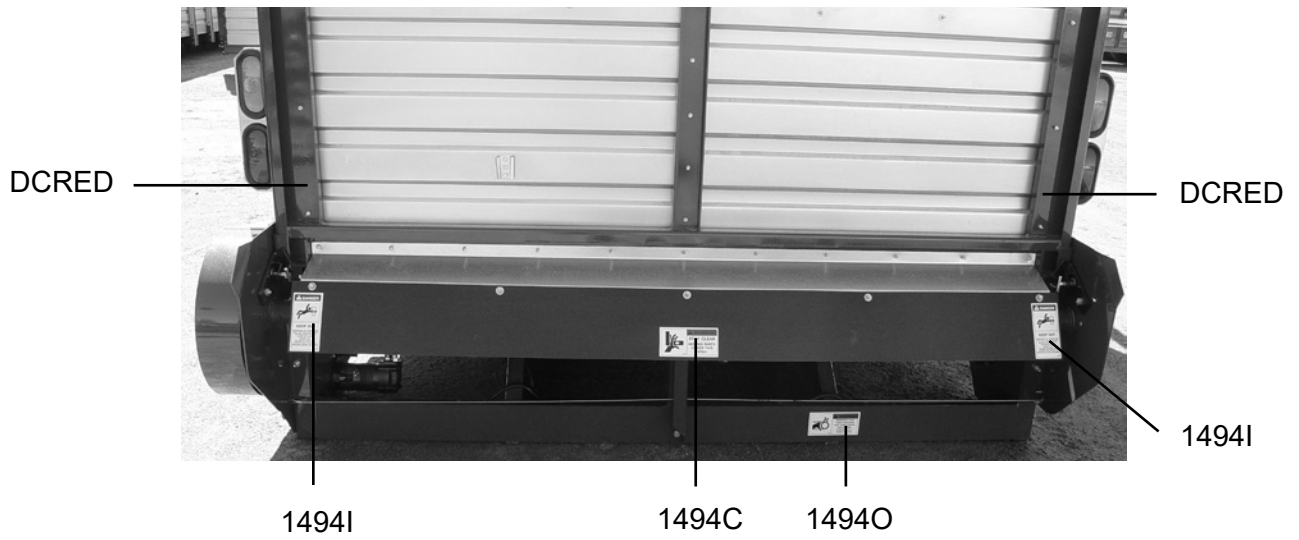

H&S MFG. CO.

products approved

for the

FEMA

SEAL OF QUALITY



Manufactured by:

H&S MANUFACTURING CO., INC.

2608 S. HUME AVE. MARSHFIELD, WI 54449

(715) 387-3414 | hsmfgco.com

