

H&S

USE AND MAINTENANCE SPARE PARTS LIST

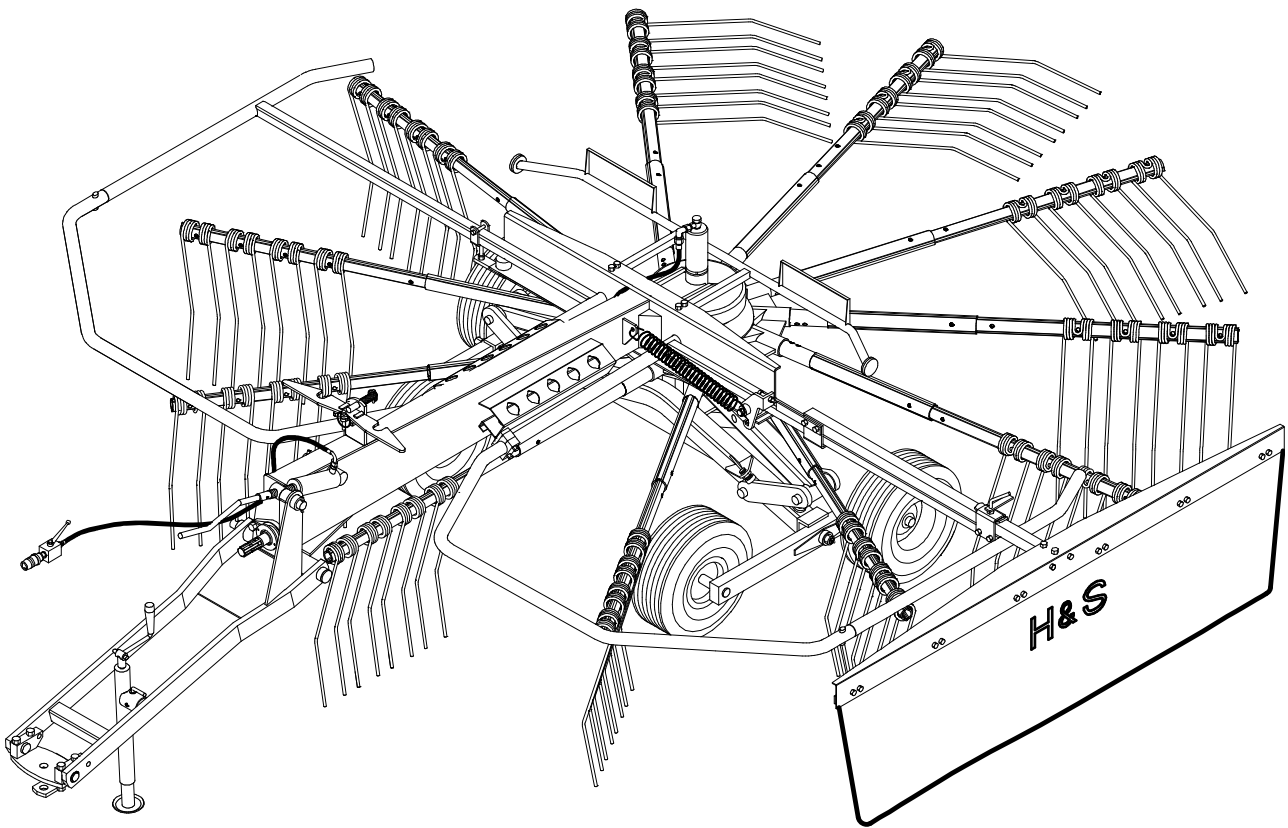

SR 420/11 H ROTARY RAKES HYDRAULIC LIFT *Pull type*

Warranty

H&S s.r.l. warrants new H&S machinery to be free from defects in material and workmanship at the time of delivery to the original purchaser if correctly set up and operated according to this Operator's Handbook.

H&S undertakes to repair or replace free of charge any defective part which should be returned by the purchaser (freight prepaid) and found to be defective on inspection authorised by H&S during the warranty period.

This warranty shall be valid for 12 (twelve) months from the delivery of the goods to the original purchaser.

If the customer is unable to return the defective part to the manufacturer, the manufacturer cannot be held responsible for any cost due for repair or replacement of any part of the machine. He shall only supply the part(s) required for such repair and/or replacement.

The warranty shall be considered null and void when it is evident that the machine has been improperly used or at least repaired without authorisation.

H&S shall not be held responsible for any obligation or agreement reached by any H&S employers, agents or dealers who do not comply with the above warranty. The manufacturer cannot be held responsible for the subsequent damages. This warranty replaces any other warranty, either explicit or implied, as well as any other obligation of the manufacturer.

CHAPTER

- 1) **GUIDE TO THE SIGNS**
- 2) **General summary of safety and accident-prevention instructions**
- 3) **PRODUCT IDENTIFICATION**
- 4) **DELIVERY AND ASSEMBLY**
- 5) **ADJUSTMENT, PREPARATION AND USE INTRODUCTION**
- 6) **TRANSPORT BY ROAD**
- 7) **MAINTENANCE**
- 8) **SPARE PARTS LIST**

**GUIDE TO THE SIGNS AND SYMBOLS USED THIS MANUAL AND THEIR
LOCATION ON THE MACHINE
IMPORTANT**

DANGER SIGNS

INDICATION SIGNS

11 Indicate an oil point.

OIL LEVEL

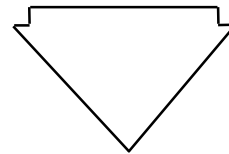

**GENERAL SUMMARY OF SAFETY AND
ACCIDENT PREVENTION INSTRUCTIONS**

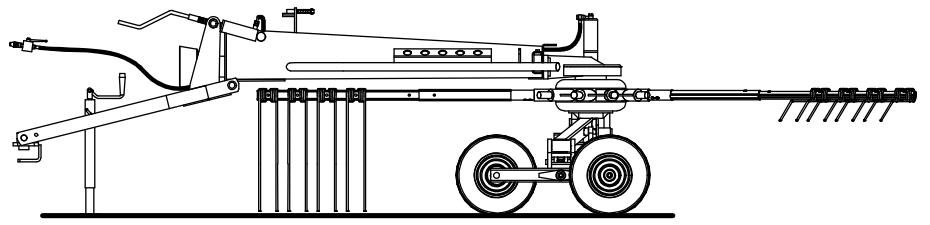

PRODUCT IDENTIFICATION

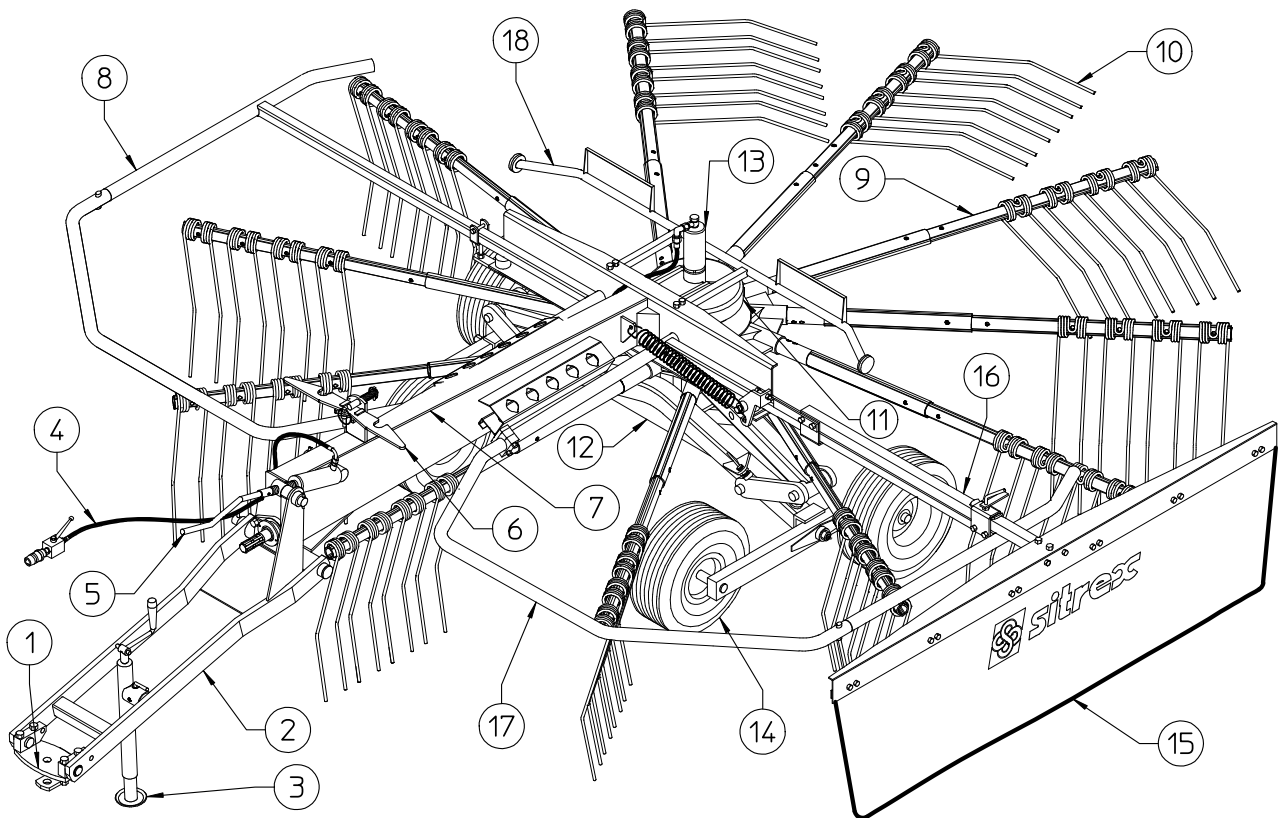

MAIN PARTS

- 1) BRACKET
- 2) DRAWBAR
- 3) PARKING STAND
- 4) HYDRAULIC KIT
- 5) CRANK
- 6) RATCHET
- 7) FRAME
- 8) R.H. GUARD

- 9) TINE ARM
- 10) TINE
- 11) GEARBOX
- 12) AXLE
- 13) CYLINDER
- 14) TIRE ASSY
- 15) SWATHING DEFLECTOR
- 16) TELESCOPING TUBE
- 17) L.H. GUARD

18) LIGHTING BRACKET

IDENTIFICATION PLATE



RPM TRACTOR	RPM ROTORS	POWER REQUIRED	WHEEL TYPE	OPERATING WIDTH	TRANSPORT WIDTH	WEIGHT
MAX 540	55	HP 40	18X8.50 8PLY	4,2Mt	2100 83"	KG 700
		KW 29		165"		LBS 1550

LOCATION OF SIGNS AND SYMBOLS ON THE MACHINE

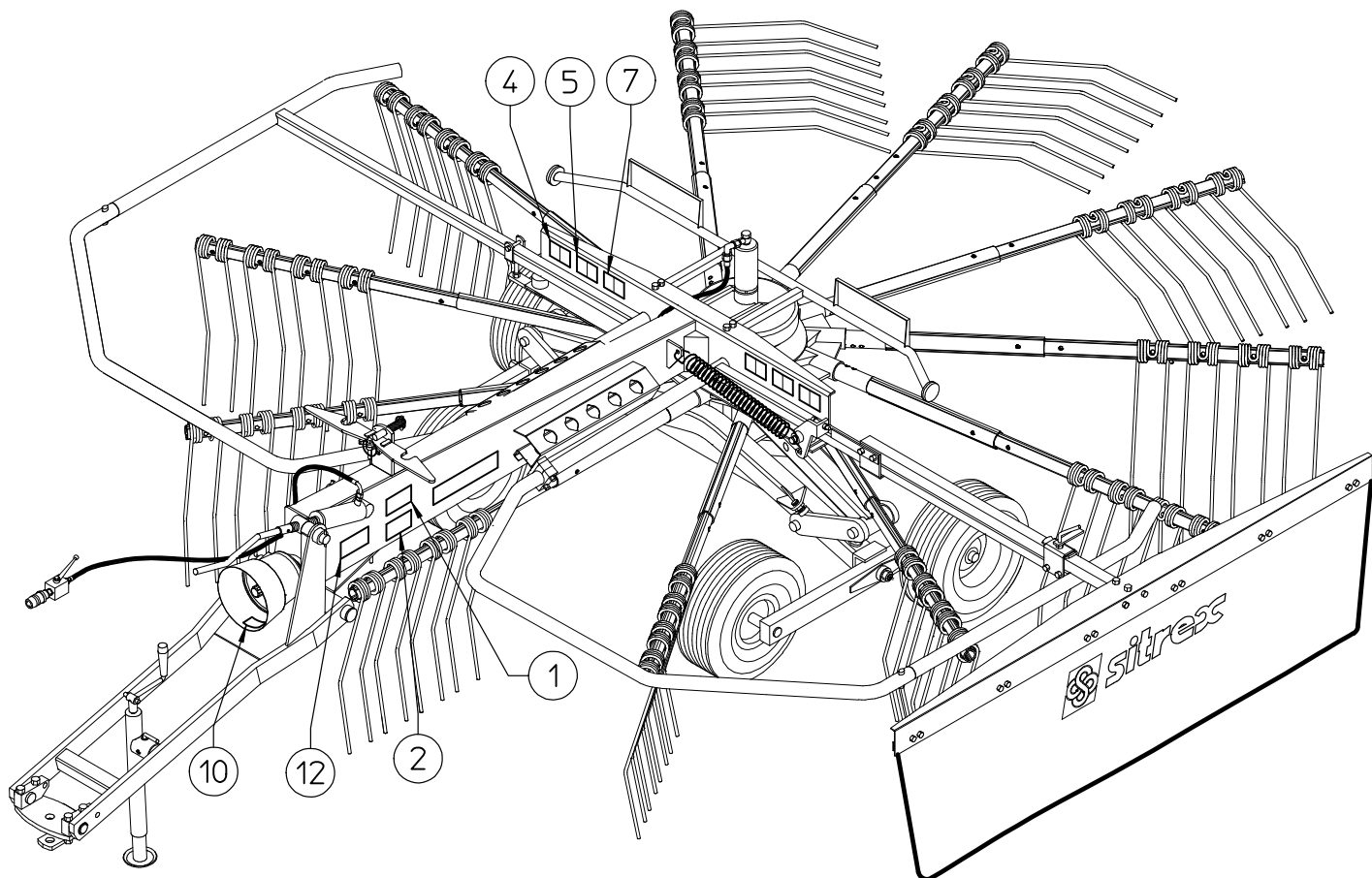

- 1) SEE DRAWING 1 P.4
- 2) SEE DRAWING 2 P.4
- 3) SEE DRAWING 3 P.4
- 4) SEE DRAWING 4 P.5
- 5) SEE DRAWING 5 P.5
- 6) SEE DRAWING 6 P.5
- 7) SEE DRAWING 7 P.5
- 8) SEE DRAWING 8 P.5
- 9) SEE DRAWING 9 P.6
- 10) SEE DRAWING 10 P.6
- 11) SEE DRAWING 11 P.6
- 12) IDENTIFICATION PLATE

CHAPTER 4

DELIVERY AND ASSEMBLY

Checking the machine on delivery

All parts are carefully checked before dispatch or delivery.

On receiving the machine, ensure that it has not been damaged during transport. If damage has occurred, contact the dealer concerned.

Details of packing are given below.

UNPACKING THE MACHINE



DANGER !!!



Lift the machine using a forklift truck, crane or other suitable equipment of sufficient capacity after first checking the weight of the configurations in the table given below.

Check the stability and positioning of the load on the forklift truck forks or crane hook.

Keep the load as low as possible during movement for maximum stability and to ensure that the operator has maximum visibility.

If a forklift truck is used, ensure that the forks are positioned as wide apart as possible.

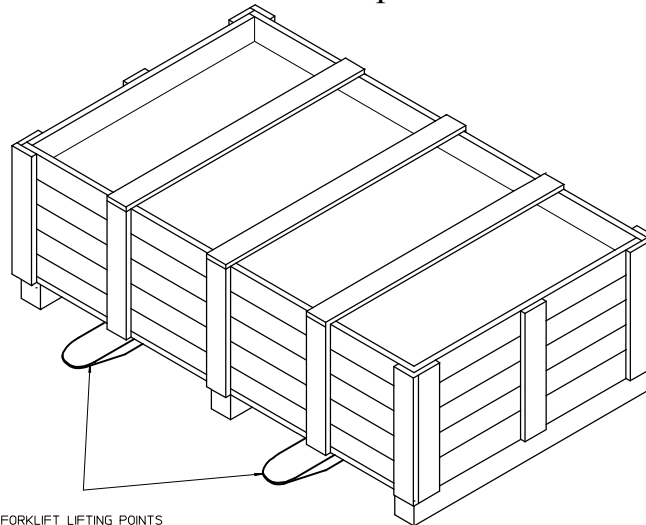

	WEIGHT PACKING	WEIGHT
KG	765	
LBS	1700	

NOTE: 1) The packing consists mainly of wood, which should be disposed of according to the laws in force in the country where the machine is used.

The plastic film should also be disposed of according to the laws in force in the country where the machine is used.

2) When storing, it is permissible to stack 2-3 crates on top of each other. Make sure that they are perfectly aligned cortically.

3) In the event of further transport, ensure that the machine when on the transporting vehicle.

ASSEMBLY



DANGER !!!



Assembly is highly dangerous and must be carried out in strict accordance with the following instructions. We recommend that qualified personnel perform assembly. We also recommend

that assembly be carried out in a flat, open area with no people (particularly children) nearby who could be severely injured if they were to touch or move any parts of the machine.

Assembly sequence:

Attach the arms (2) to the housing (1), placing them over the pins (3). Fasten the arms by inserting spring pins (4) into holes (A), and then insert the inside spring pins (5).

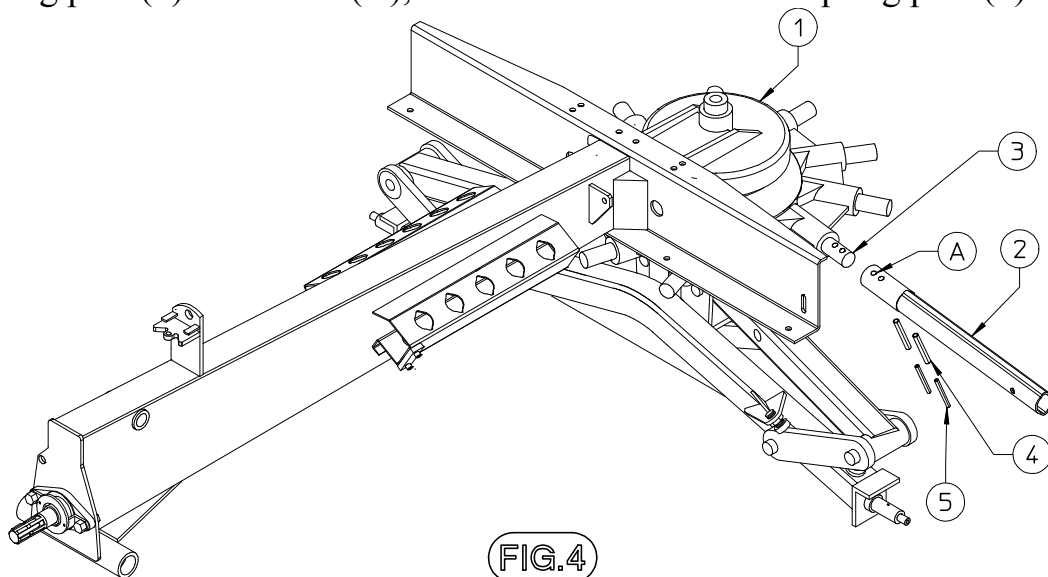

FIG. 4

Attach the cylinder-adjustment assembly (2) to the drawbar (1), fastening with the spring pin

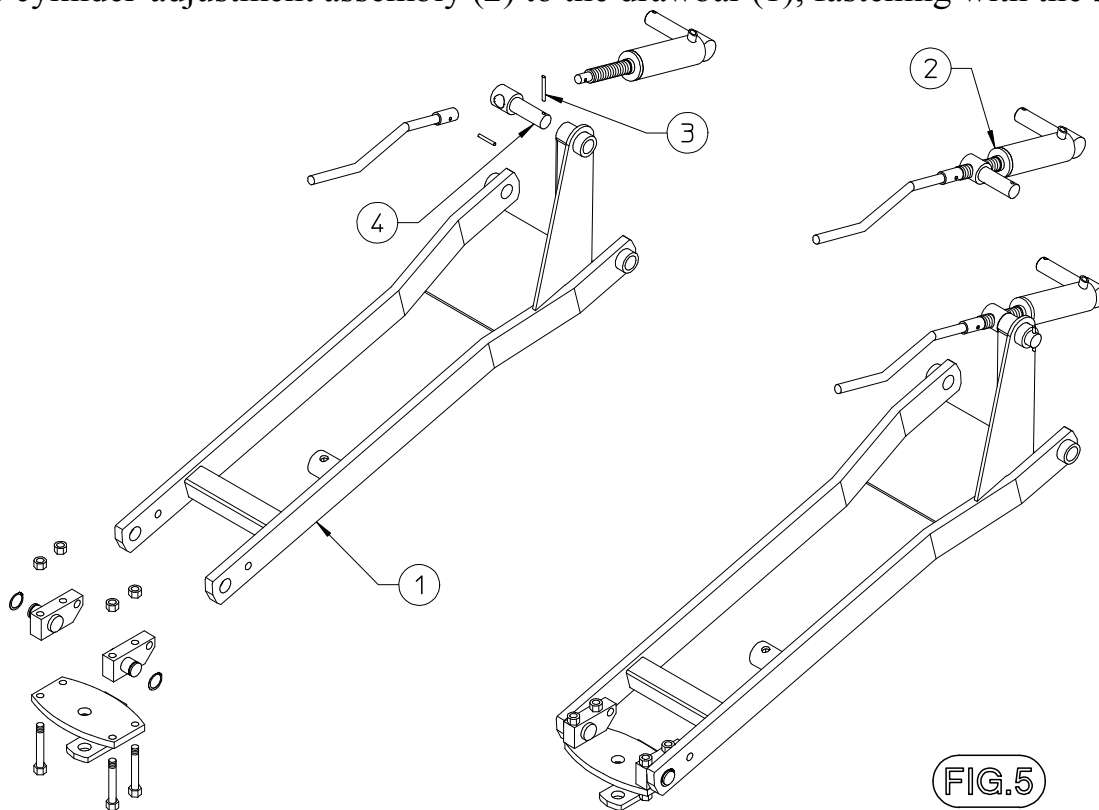

FIG. 5

Rest the main frame (2) on stands and then insert the wear bushings (5). Insert pin (3) into hole (A) and fasten with the spring pin (42). Position the drawbar (1) so that pin (6) can be inserted, and fasten pin (6) with the spring pin (7).

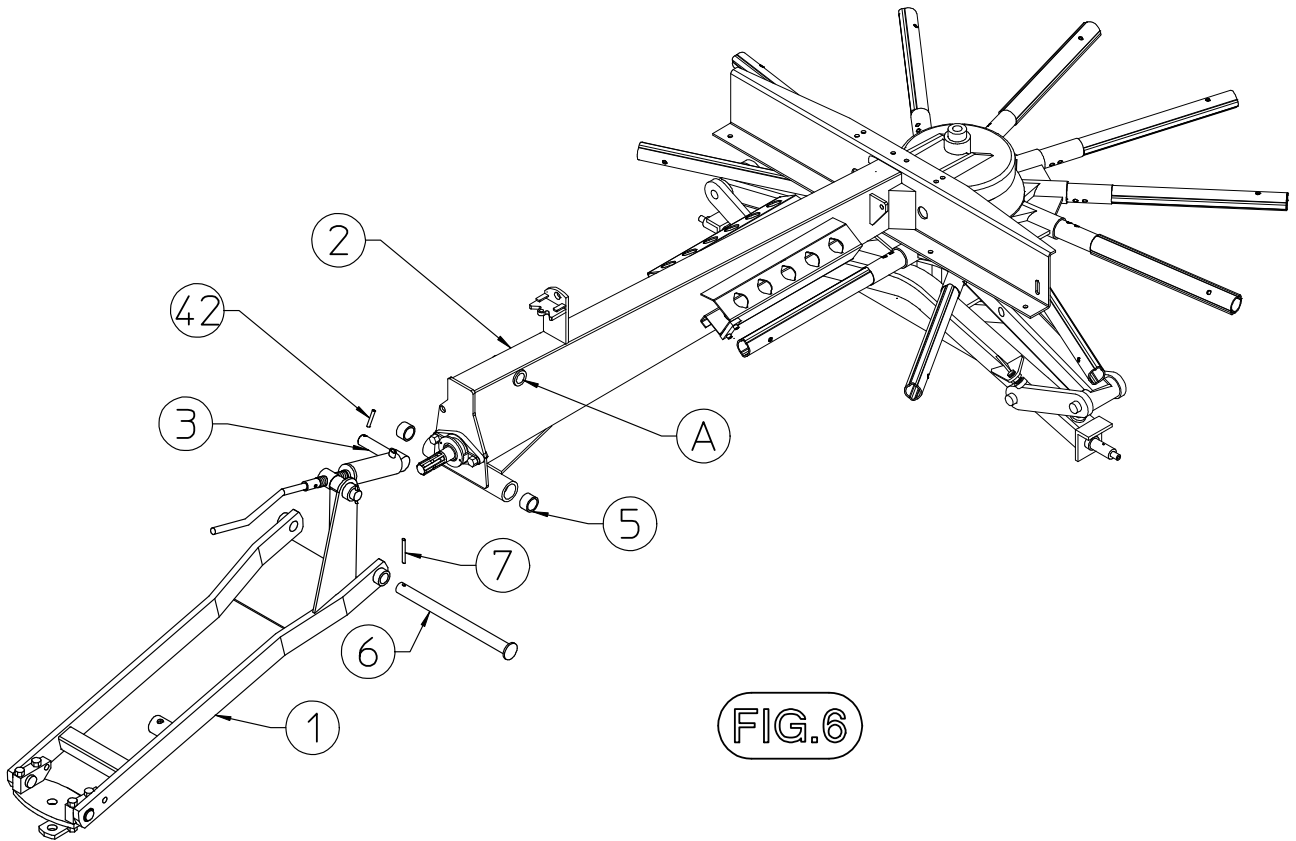

FIG.6

Attach grease nipples (17) to the axle (2). Next check to see that the wear bushings are in place on the wheel tandems (5), and mount the tandems on the axles, inserting spacers (3) and (6), in order to limit play (the longer part of the wheel tandem should face the tractor), and fasten with the washer (7) and nut (8). Mount wheels (10) on the tandem pins, first placing the large guard (9) and then the small guard (11), the washer (12) and tighten with the nut (13). Mount the parking stand (14) to the mount on the drawbar (1), and fasten with pin (15) and clip (16). The machine can now be placed on the ground.

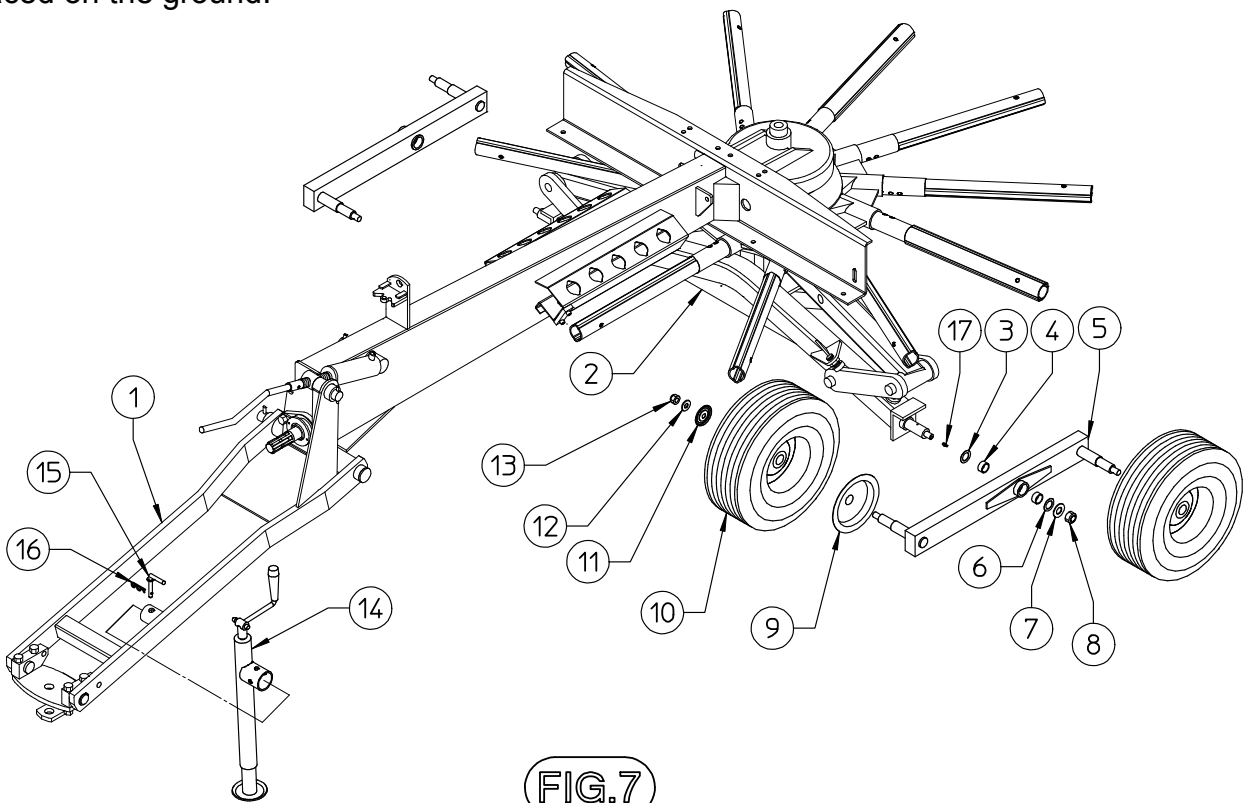

FIG.7

HYDRAULIC SYSTEM ASSEMBLY

Remove the guard on the central screw of the housing (1), and then screw on the cylinder (6), without touching the ring (2) or the lower toothed washer (4). When the cylinder is tight, bend one of the tabs of the upper-toothed washer (5) on the milled part of the cylinder so as to fasten it. Loosen screw (7) and turn the curve (8) towards the tractor hitch, then tighten screw (7) and nut (18). While doing this operation, the barrel of the cylinder could be loosened from the head ring, so check at the end of the operation to make sure that it is tight. Attach the hydraulic line (9), which can be recognized by the inner gasket on the curve (8), passing it through hole (A). Next attach the T connector (10) with lines (11) and (14), and fasten the lines into the working position using the three line clamps (13), without pulling the lines tight; in the area where the main frame is joined to the drawbar, the line must make an arch, so as to allow movement between the two parts. Check carefully to make sure that the opening of the tilt adjustment cylinder does not pull on line (14). If it does, lengthen the loose section between the two line clamps (13) that hold the lines in this area. The short line (11) feeds the tilt adjustment cylinder and is attached by means of the nipple (12) and washer (17). Attach the tap (15) and quick-release coupling (16) to the end of line (14).

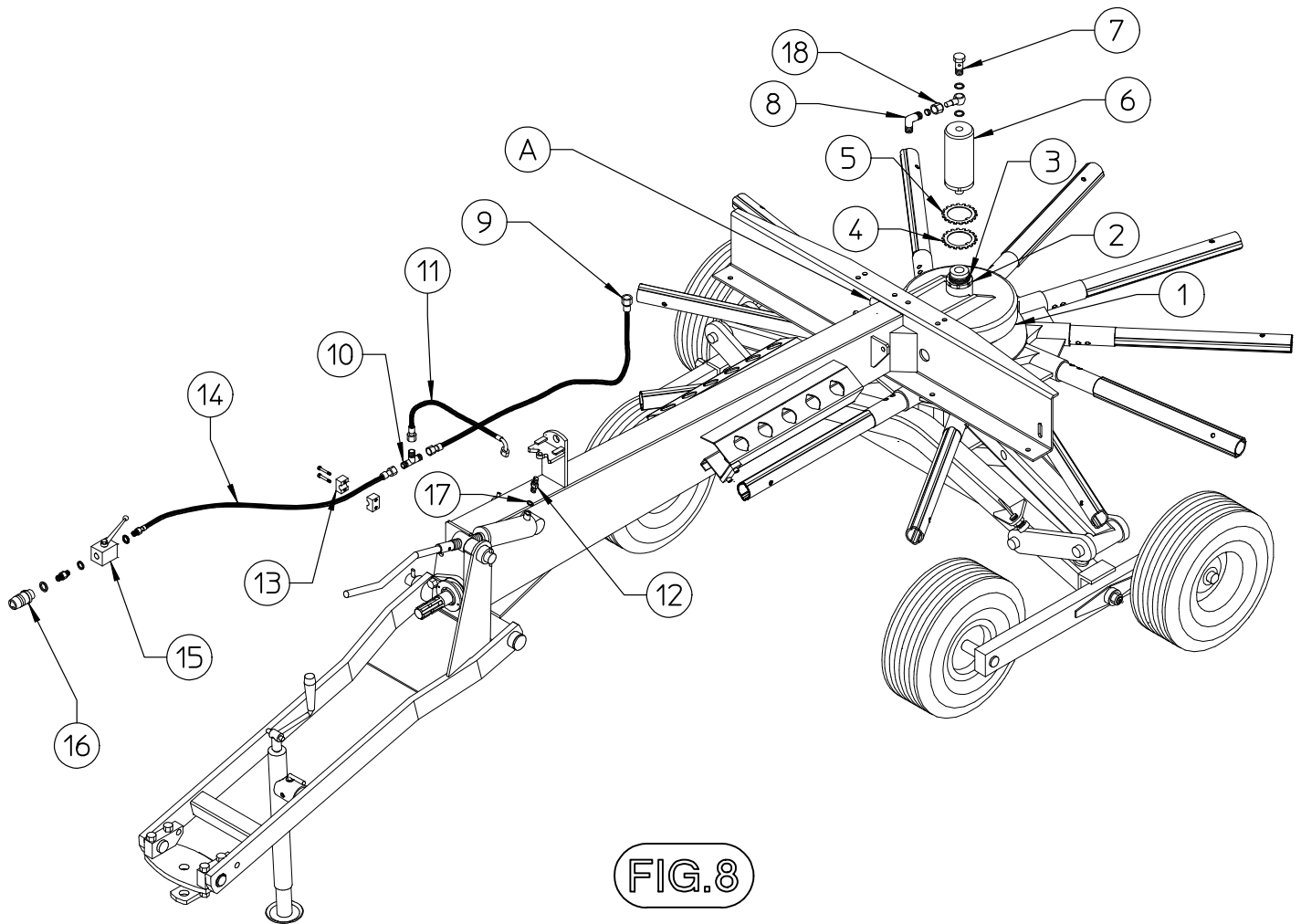

FIG.8

Mount the safety hook (2) by inserting it into hole (A), and then place the spring (4) and washer (5) over the pin, fastening in place with pin (6). Insert safety pin (7) in hole (B).

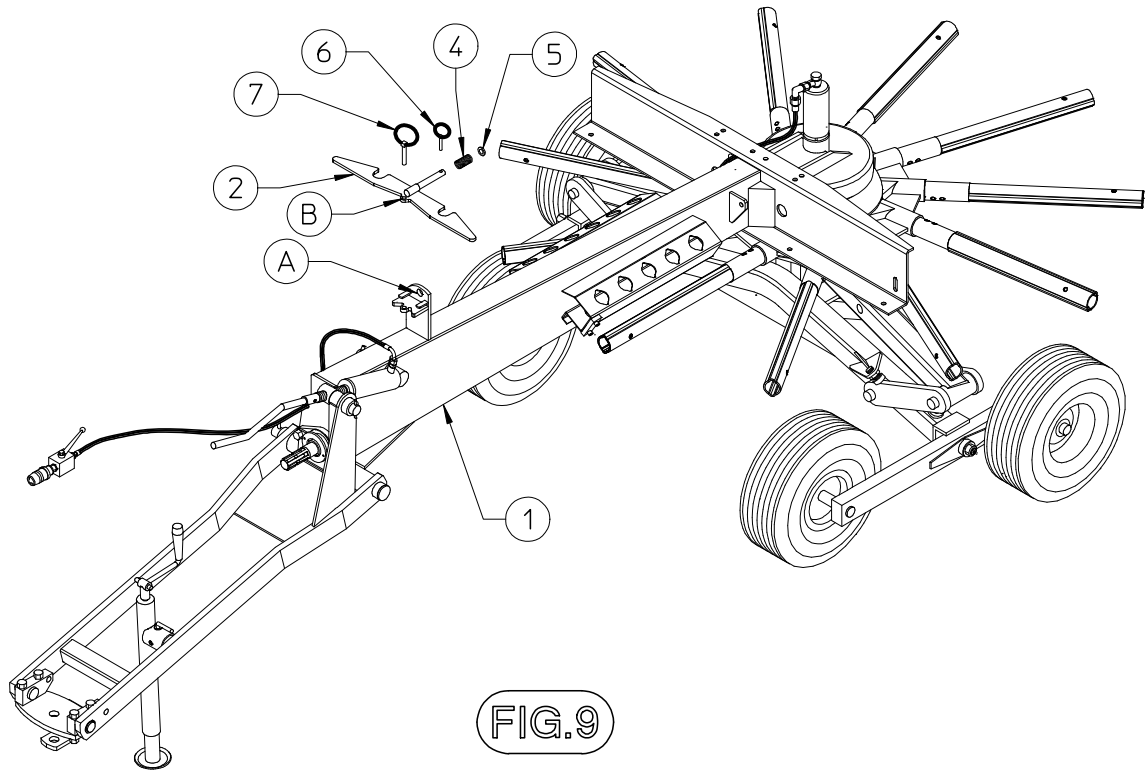

FIG.9

ATTENTION: Mount the high rubber pad (7) to the right outside hole with nuts (6), taking also the plate (8); in the other holes the low rubber pads (5), in the left outside hole fasten also clamp (2) with screw (3) and washer (4). Mount protection frame (11) to the left support (10) using screws (12) and nuts (13), then insert the assembly into the hole as shown in the illustration, fastening the protection frame with pin (17) and clamp (14), and attach cap (20) to the end of the protection frame. Mount bracket (9) to the plate (8) and then mount protection frame (16) to the right support (15) and insert the assembly into the hole, following the same procedure used for the left side of the machine.

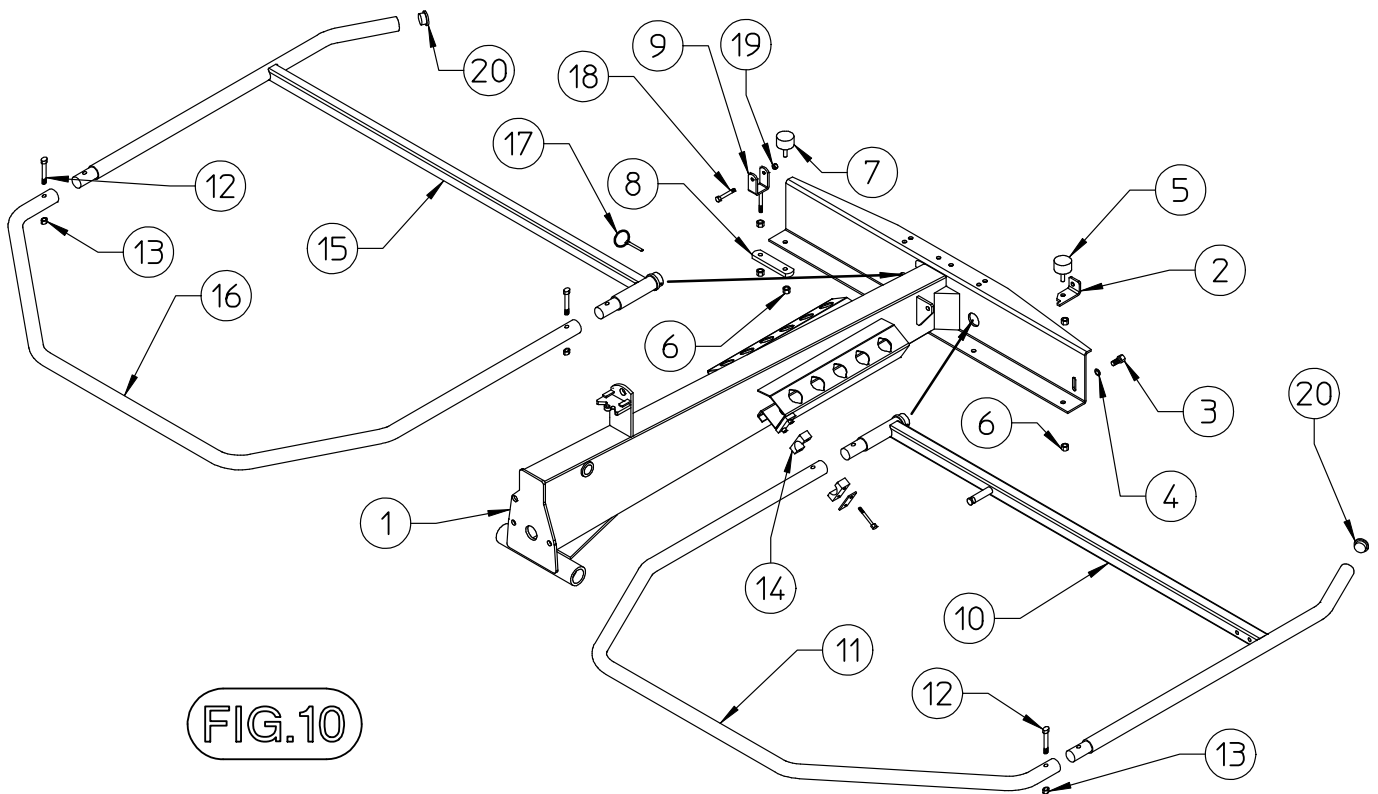

FIG.10

Mount safety hook (1) on to the pin (A) welded on to the frame, mount on safety hook the screw (2) and nut (3). Mount spring (4) to help suspension between the pin and the plate welded on the drawbar (see following diagram).

Adjust screws (M10 x 60 fully threaded) so that the safety hook turns partially and is positioned vertically when the protection frame is horizontal.

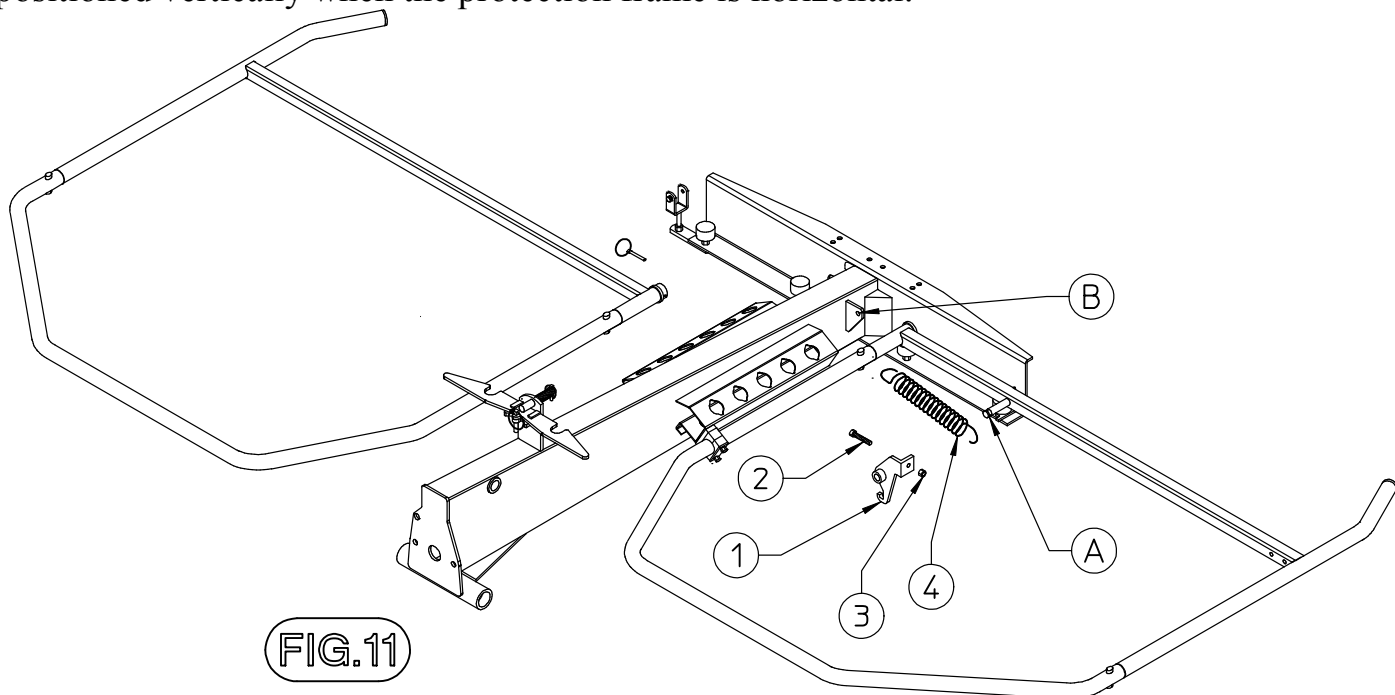

FIG.11

Use brackets (22), screws (18) and (15) and nut (10) to mount plate carrier extension (19) on to the left-hand protection frame. Also mount plate (14) on the outside of the internal bracket, whereas plate (24) must be mounted on the inside of the external bracket. In order to fasten the extension tighten screw (20) and lock (21). Use screws (8) to mount signal frame (6) on to the frame (1).

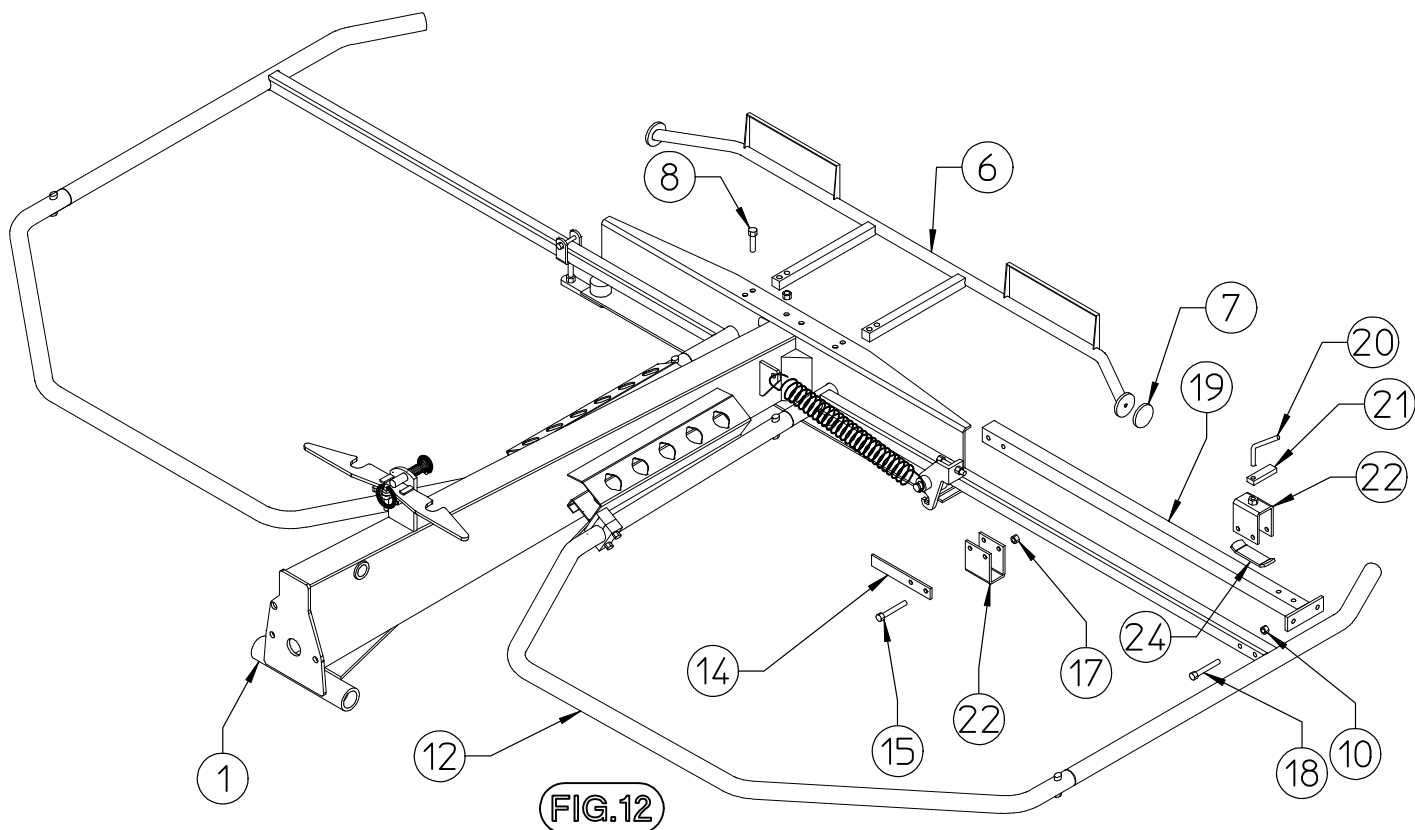

FIG.12

In order to mount swathing deflector (29) insert the slanting metal tabs (30) into the external slots and the straight tabs into the central slots, and then rest the swathing deflector on the inside of side frame (27) and place plate (28) on the outside; use screws (32) and nuts (33) to fasten everything into place.

Now use screws (23) and (26) to mount this group on plate carrier extension (19).

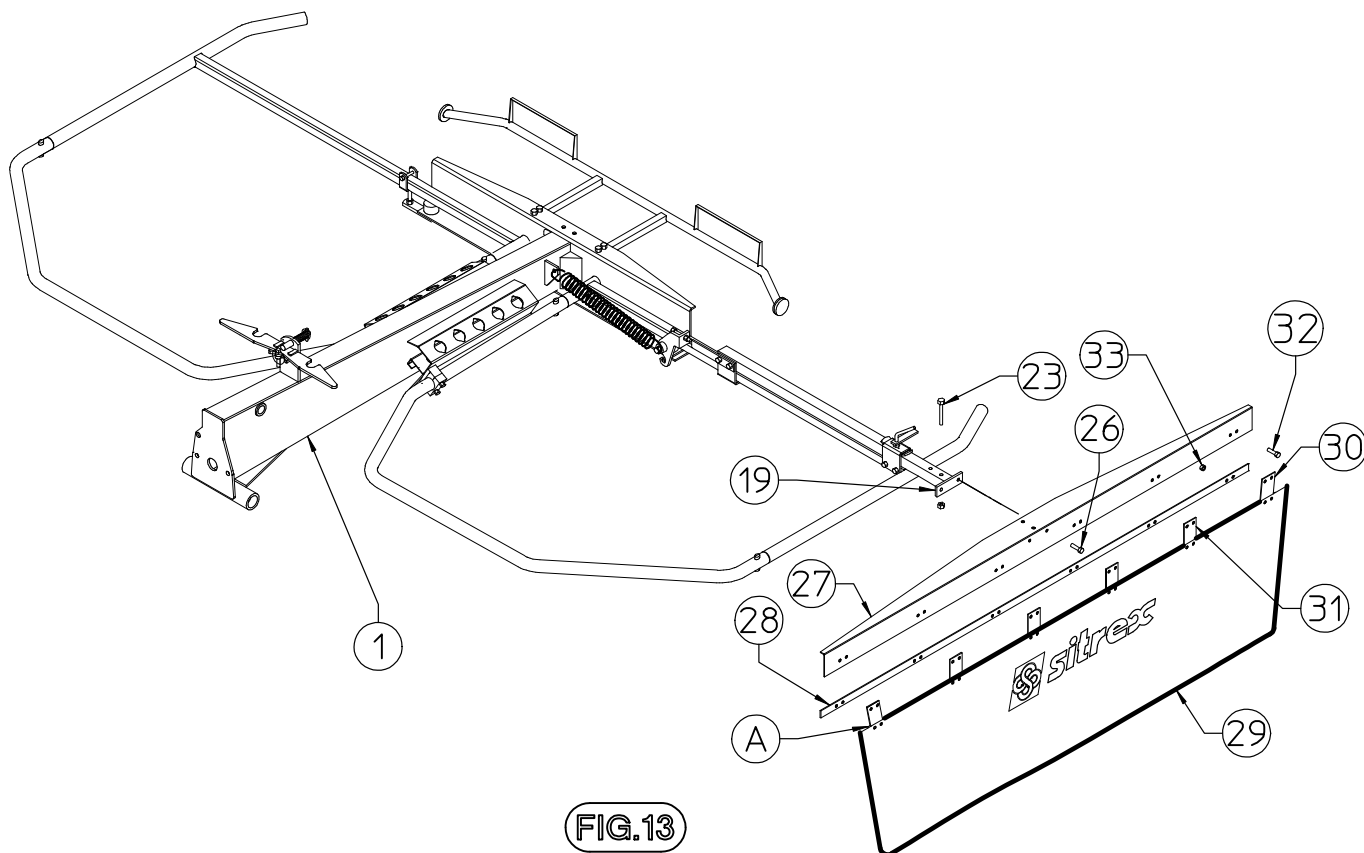

FIG.13

Attach the universal joint casing (2) to mount (10) using screws (3), nuts (4) and washers (5).

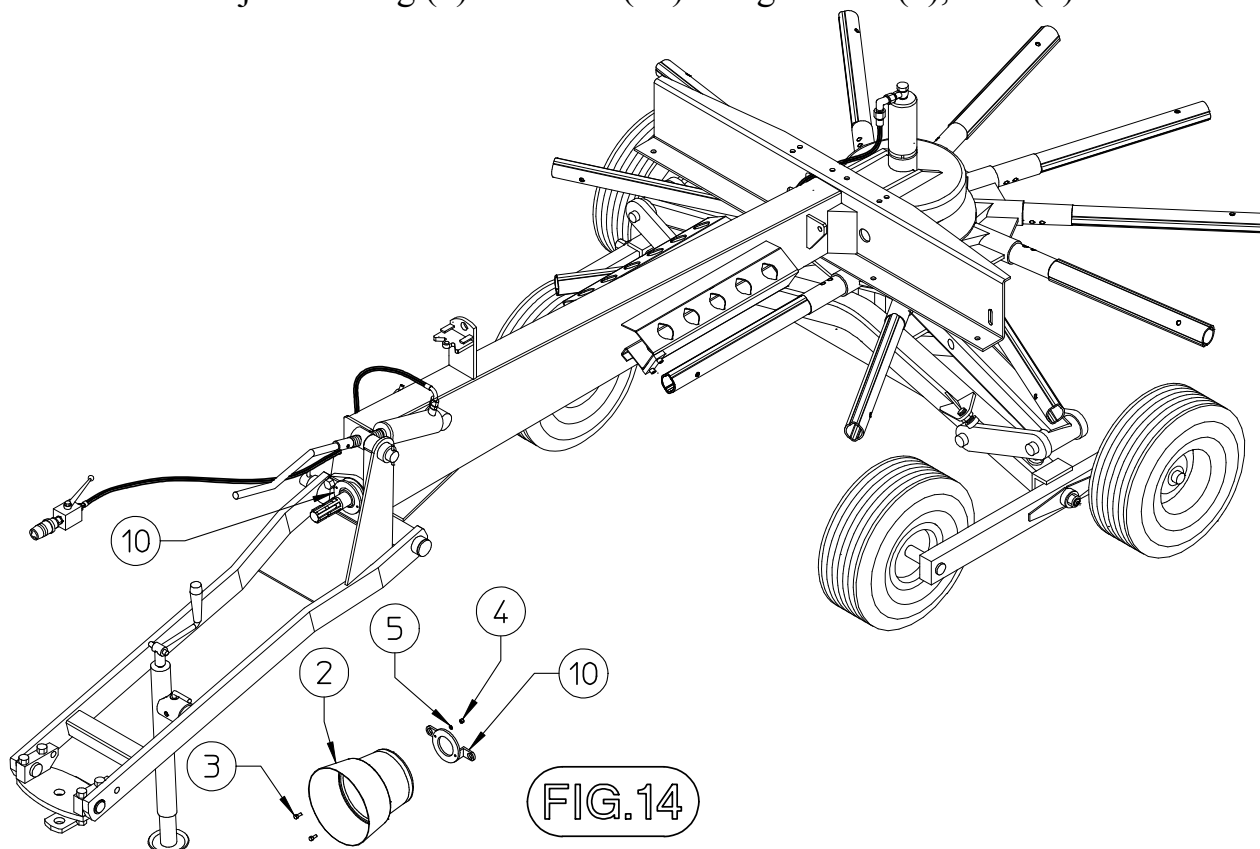
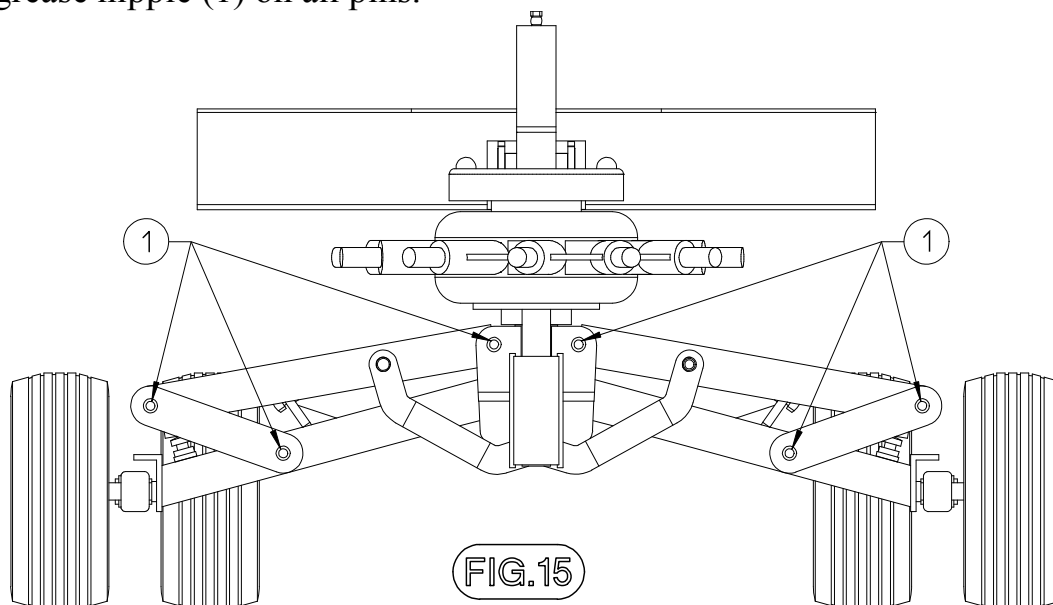
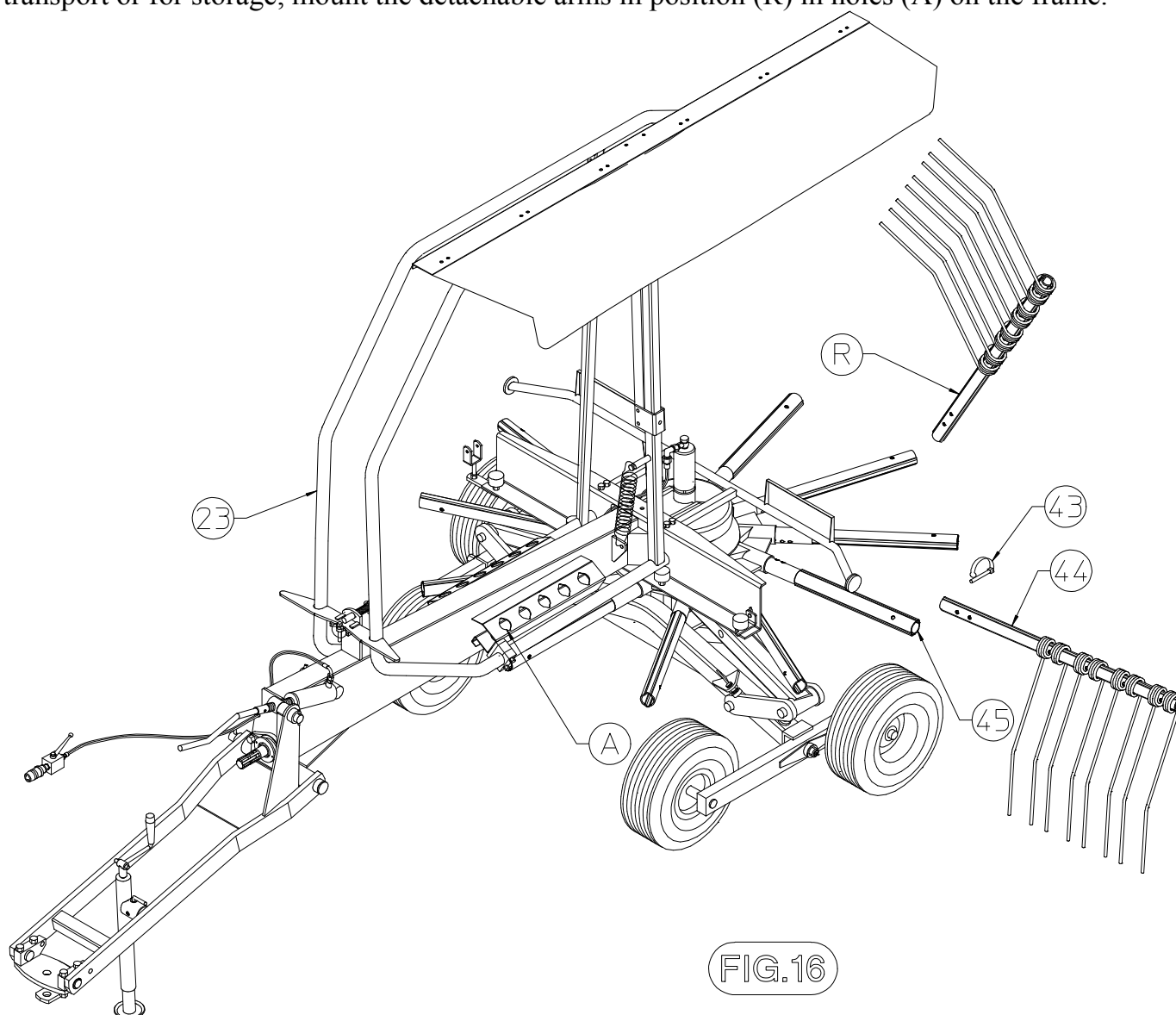

FIG.14

Mount the grease nipple (1) on all pins.



Before assembling the rake arms, raise the protection frames and use hook 23 to hold them up. If the machine has to be set up for work, mount detachable arms 44 on to the fixed arms 45 and fasten them with pin 43; the two holes on the detachable arms are to adjust swath width. The maximum working width is obtained by assembling the arm on the innermost hole. If the machine has to be prepared for transport or for storage, mount the detachable arms in position (R) in holes (A) on the frame.



CHAPTER 5

ADJUSTMENT, PREPARATION AND USE

INTRODUCTION



DANGER !!!



Connection to the tractor is highly dangerous. Take great care and carry out the entire operation in strict compliance with the following instruction.

Nobody should go near the area between the tractor and the machine.

Check that all warning and danger signs are in place and legible.

Check that the tractor is in good running order. Check the engine oil, gearbox oil, brake fluid and cooling water levels as well as the tire pressures.

Refer to the tractor operator's manual.

CONNECTION TO THE TRACTOR

Connect the machine to the tractor, hitching it to the drawbar bar at point (1). If the two-point crosspiece is used, lock the equalizers (10) using the optional screws (8) and nuts (9). **Attention: do not use screws (8) if the machine is hitched to the drawbar.** After the machine is hitched, loosen the parking stand (2) and remove pin (3), then rotate the stand upward towards the back of the machine and insert pin (3) to hold it in the resting position.

Once this procedure is completed, insert the quick-release coupling (4) into the tractor socket and open the tap (the lever must be parallel with the line, as shown in the illustration). At this point, work carefully with the hydraulic distributor to make sure that the frame is completely lowered, and then adjust the height of the tines above the ground. To change the distance between the tines and the ground, turn screws (6). By rotating the crank (7), the tilt of the machine relative to the ground is adjusted.

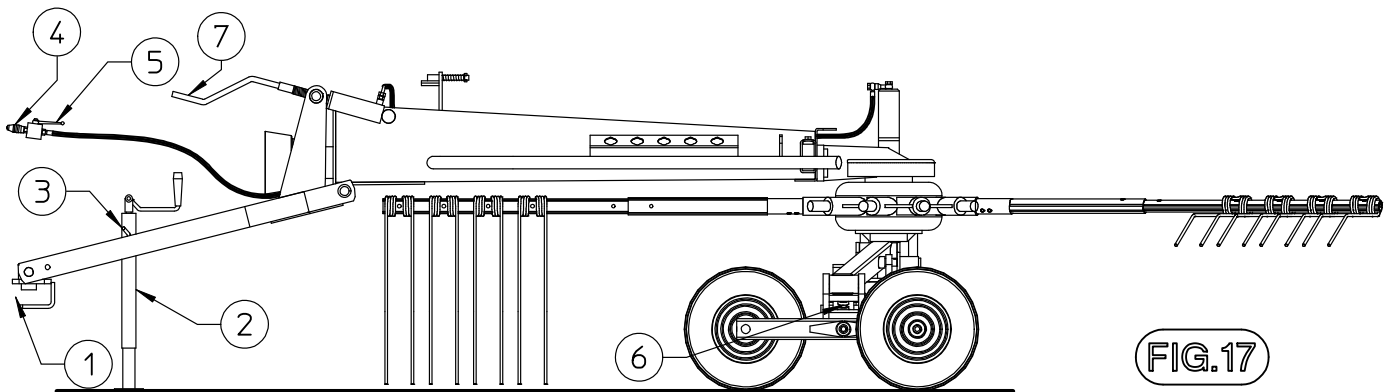

FIG.17

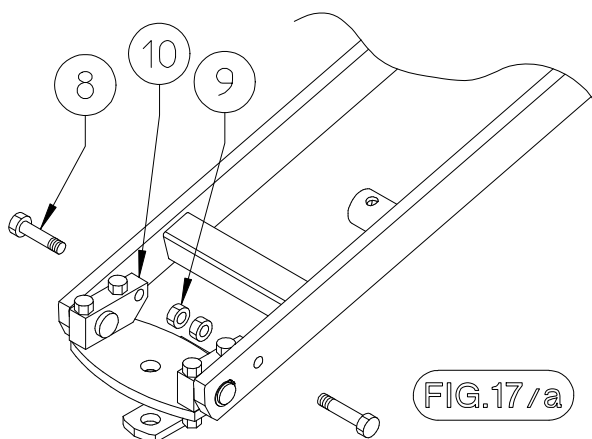

FIG.17/a

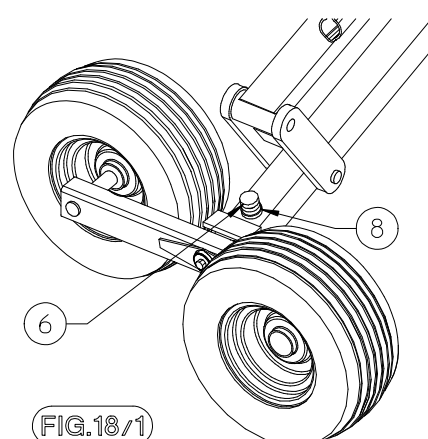

FIG.18/1

CONNECTING THE CARDAN SHAFT

DISASSEMBLY OF THE TRACTOR

In order to park the rake, make sure that the ground beneath it is flat and is able to bear the weight of the machine.

When the rake is raised and lowered, no one should be standing between the tractor and the machine or near the machine.

Before disconnecting the machine from the tractor, use the hydraulic system to lower the machine completely, then apply the brake and shut off the tractor. Dismount from the tractor and place the parking stand in the vertical position (pos. 2, Fig. 18). Turn the crank to raise the machine from the drawbar so that the hitch pin may be removed from the tractor. Disconnect the quick-release coupling (4). Disconnect the cardan shaft and lay it against the parking stand crank. The tractor may now be moved away.

If there are problems with space, when not in use the machine may be left in the position shown in Fig. 16.

Attention: the machine should be in the high position only when being transported.

ADJUSTMENT OF THE FORAGE RAKE

The machine has to be adjusted when it is attached to the tractor.

Adjustment of work depth

Adjustment of working height

The working height is adjusted by turning screws (6) and nut (8) and by rotating crank (7); it is advised to adjust the front tine so that it is 1 3/8" from the ground, and to keep the machine tilted slightly towards the front. The rear tine should be about 3/16" farther away from the ground.

If adjustment is too high, the forage will not be completely picked up and if it is too low, the forage risks becoming dirty, the grass will be damaged and the double elastic tines will be worn down.

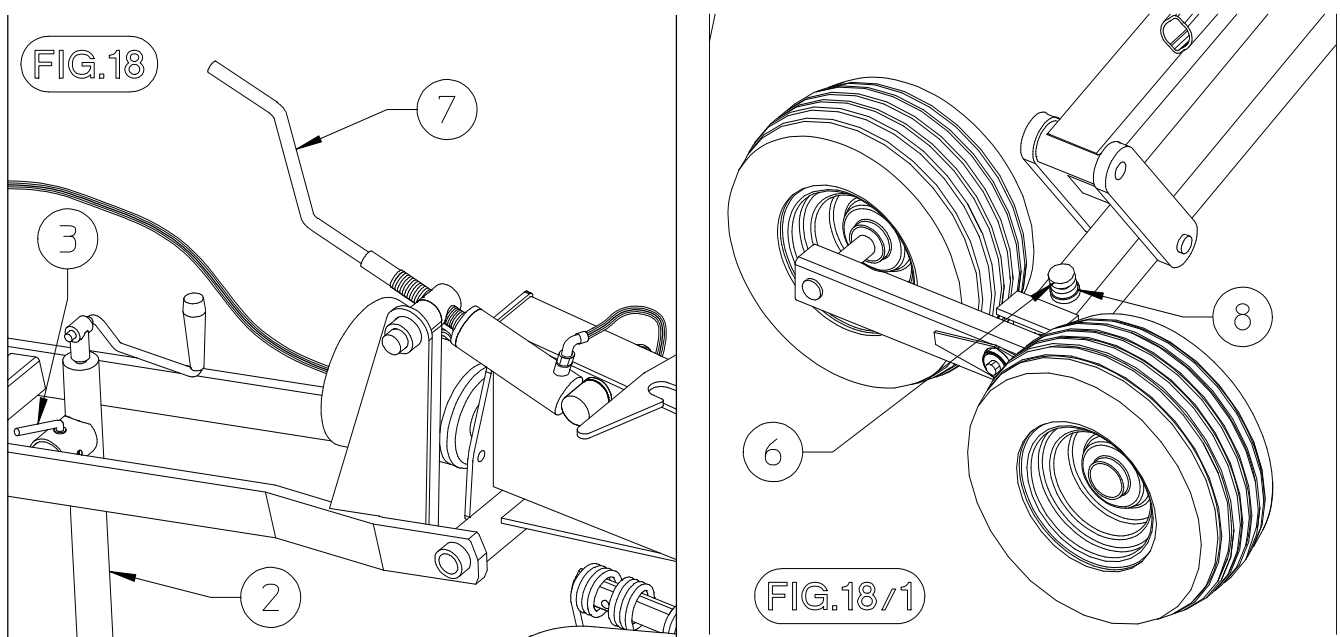

When the working height is being adjusted, set the screws (6) and relative nuts (8) so that the machine as seen in Fig. 19 is parallel to the ground.

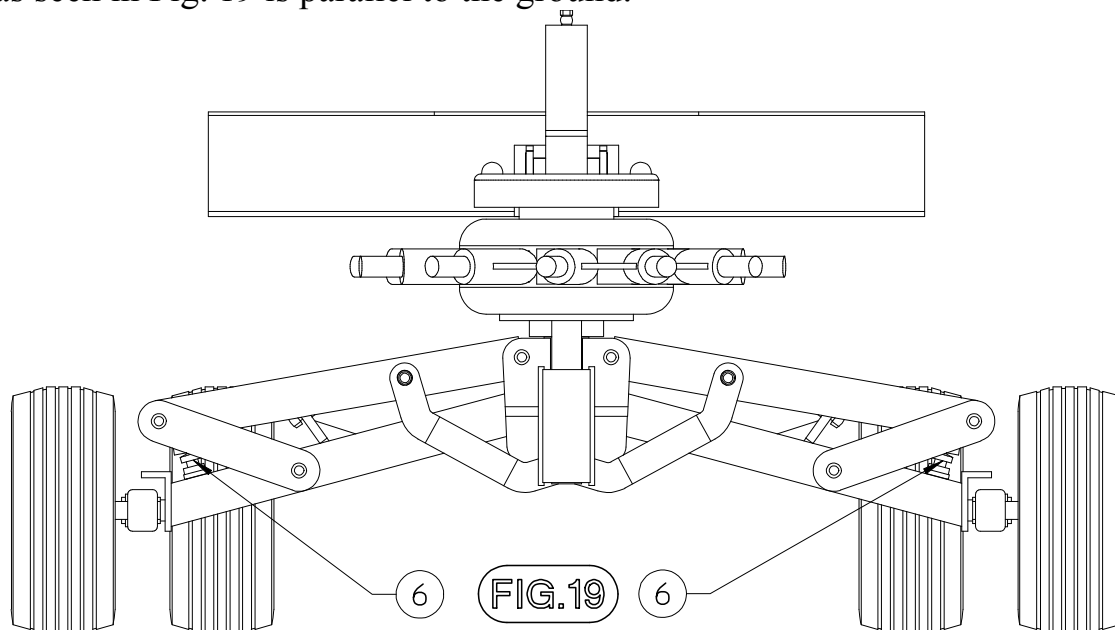

After having adjusted the work height of the tine, use nuts 5 under clamp 10 to set the distance of the plate from the ground.

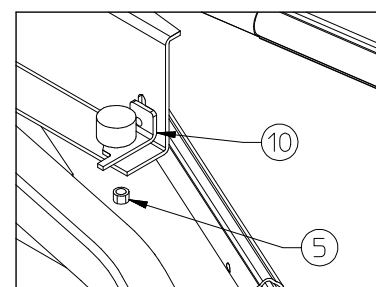

The distance between the swath-shaper plate and the rotor determines the size of the swath and on this depends the amount of forage. Adjustment is continuous and a large amount of forage means making a larger adjustment.

In order to carry out adjustment, loosen lock 21 and screw 20 and then move plate carrier 27 to the required position and tighten first screw 20 and then lock 21.

In the work position check that safety hook 13 fits into lock 10 in order to fasten the swath-shaper plate into position.

Adjustment of gear speed and revs to work the machine

The gear speed and machine revs depend on:

- the amount of forage
- the type of ground
- the degree of dryness

The forage rake was designed for a maximum number of revs for the power take-off of 540 g/min. We advise working with a rev number of 350-450 g/min. Gear speed should be limited so that the rake works cleanly and the swath is well formed.

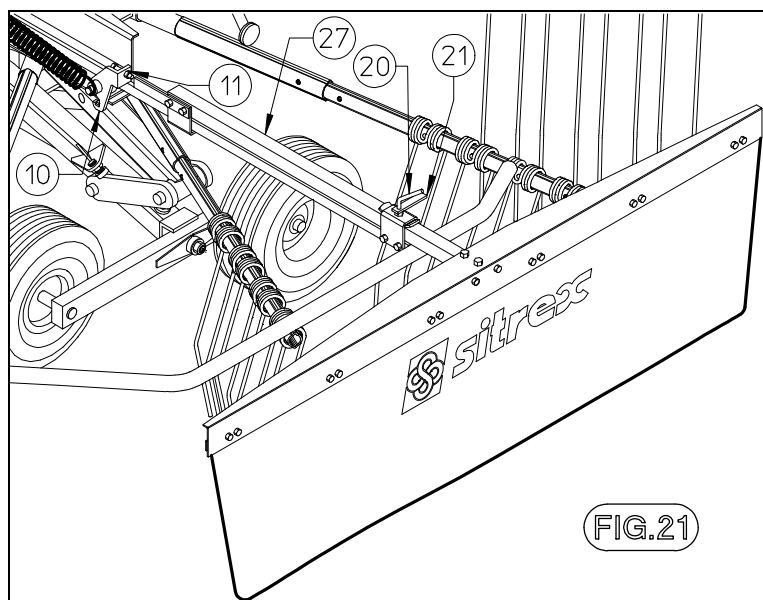

TRANSPORT

If the machine is used on the road, make sure it complies with traffic regulations in your country; use regulation lights and comply with the safety regulations.

Preparation for transport

The machine may be transported for short distances after having raised it with the hydraulic system. When transporting for longer distances, close the tap (5). This operation must be done regardless of distance when transporting on public roads. When lifting the machine, make sure that the outside arms (1) move all the way until they touch the stops (2).

During transport or storage it may be necessary to have the machine occupy less space. To do this, follow the procedure given below (see Fig. 16).

Loosen the swath-shaper plate carrier and reinsert it until the safety hook is released, then tighten the lock screw once again.

Turn the protection frames facing upward one at a time and use hook 23 to fasten them, insert safety clamp 24 into the special slot.

Remove tine carrier arms 44 from their slots and take out lock clamps 43, insert the arms into the special slots on side frame 1; the arms should be inserted with the tines facing into the machine. Clamps 43 should be placed into the holes on the rotor arms.

By detaching the arms and lifting up the protection frames, it is possible to have a narrower width if necessary for transport; the machine itself does not require these operations.

Remember to open the tap and lower the machine after transport operations are completed.

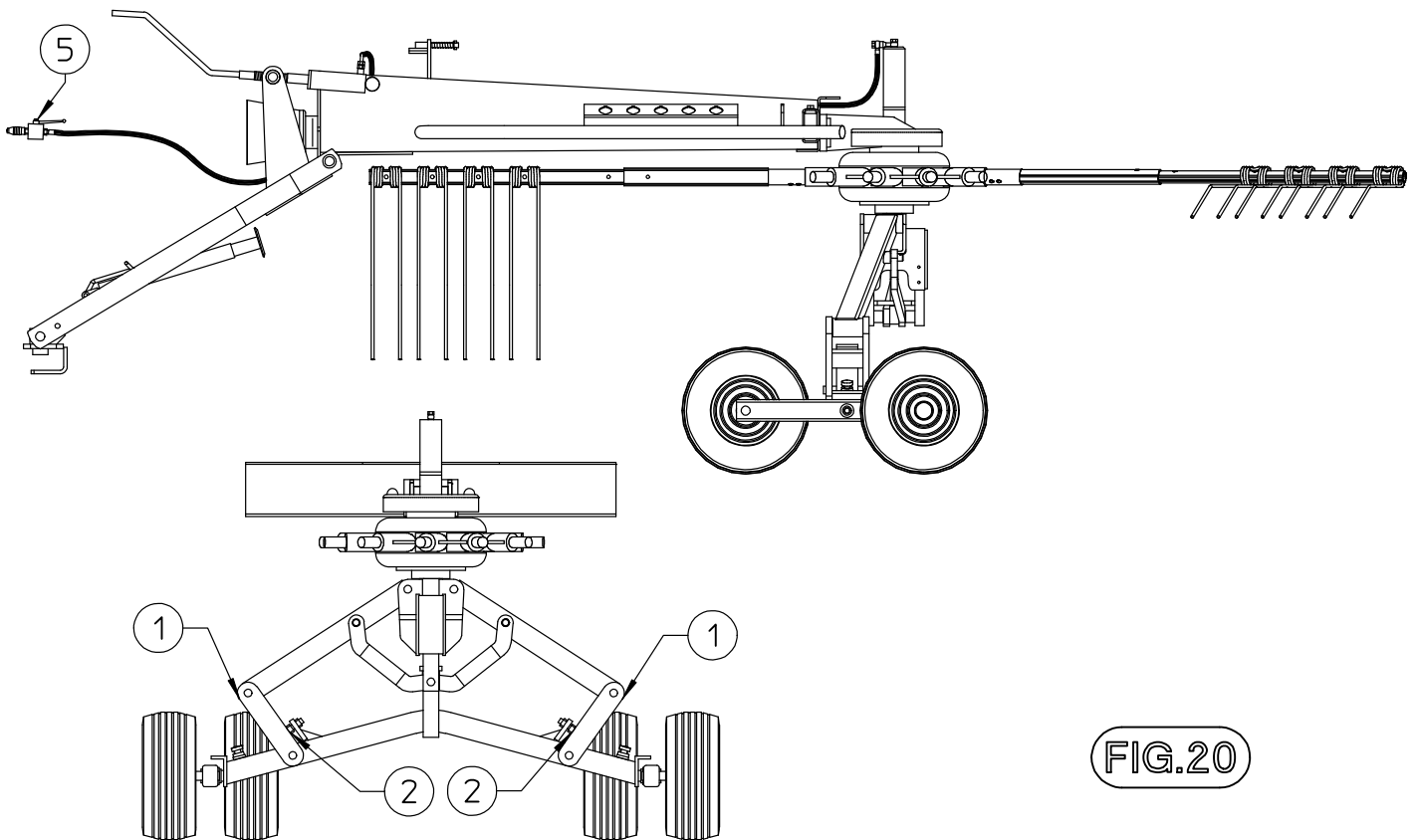
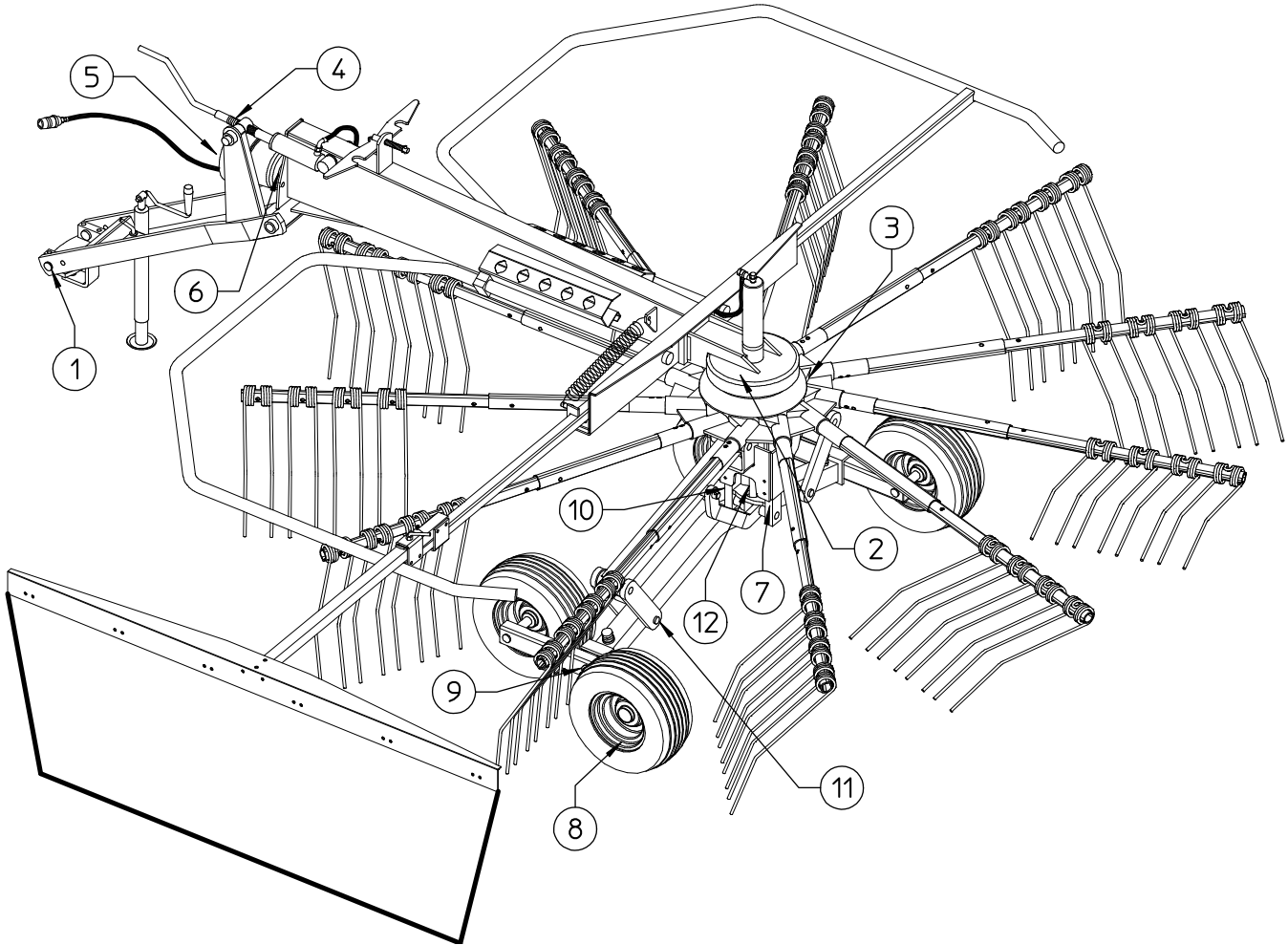

FIG. 20

MAINTENANCE DIRECTIONS

GENERAL INSTRUCTIONS FOR REPAIR WORK

MAINTENANCE POINTS



Number	Q.ty	Description	Operation	Every hours	Product to be used	Notes
1	2	Equalizer	Greasing	16	Grease	
2	1	Gearbox	Greasing	8	Grease	
3	1	Gearbox	Oil level	50	Oil SAE90EP	
4	1	Screw	Greasing	20	Grease	
5	1	Power takeoff shaft	Cleaning Greasing	A	Additives Grease	
6	1	Bearing	Greasing	20	Grease	
7	4	Sliding	Cleaning Greasing	B	Additives Grease	
8	4	Tyres	Check pressure	B	Compressor	45 psi
9	2	Axle tandem	Greasing	20	Grease	
10	1	Sliding	Cleaning Greasing	B	Grease	
11	6	Pin	Greasing	8	Grease	
12	1	Rod (210.680)	Greasing	8	Grease	
	2	Cardan shaft	Greasing	8	Grease	

General checking of bolts, security pins and split pins to be carried out initially after the first 8 hours of use. Subsequently every 50 hours and whenever the machine is laid up for extended periods.

A = Each time the Cardan shaft is disconnected and Whenever the machine is stopped, we recommended that you clean the power takeoff shaft and replace the protective cover.

B = Each time the machine is connected to the tractor.

Additives of a type permitted by anti-pollution regulations.

CARDAN SHAFT MAINTENANCE

NOISE AND VIBRATION

Noise affecting the tractor driver (from the machine only) is less than 70dB.

Vibration from the machine affecting the upper body and limbs of the driver is insignificant and is lower than the values given in Point 3.6.3 of Enclosure 1 of the Machine Directives (89/392/EEC, 91/386/EEC)

THE FOLLOWING SHOULD BE NOTED IF THE MACHINE IS SCRAPPED

The machine consists mainly of ferrous material, which must be disposed of according to the regulations in force in the country concerned.

There is also a small amount of plastic, which must be disposed of according to the regulations in force in the country concerned.

There is very small amount of residual grease, which must be disposed of according to the regulations in force in the country concerned.

SPECIFICATIONS	420/11
Number of arms	11
Number of double tines per arm	4
Working width	4,20 / 13'-9"
Rotor diameter (raking width)	3,40 / 11'-2"
Transport width (with arms disassembled)	2,00 / 6'-7"
Transport width (with arms assembled)	3,50 / 11'-5"
Maximum height of tine from ground	0,33 / 1'-1"
Power required	30kW / 40HP
PTO driveline with overload clutch	540 RPM constant velocity overload clutch protects gearbox
Hydraulic requirement	1,000 PSI
Weight	700kg / 1550lbs
Tires (tandem axle)	18 x 8.50 x 8

SPARE PARTS LIST

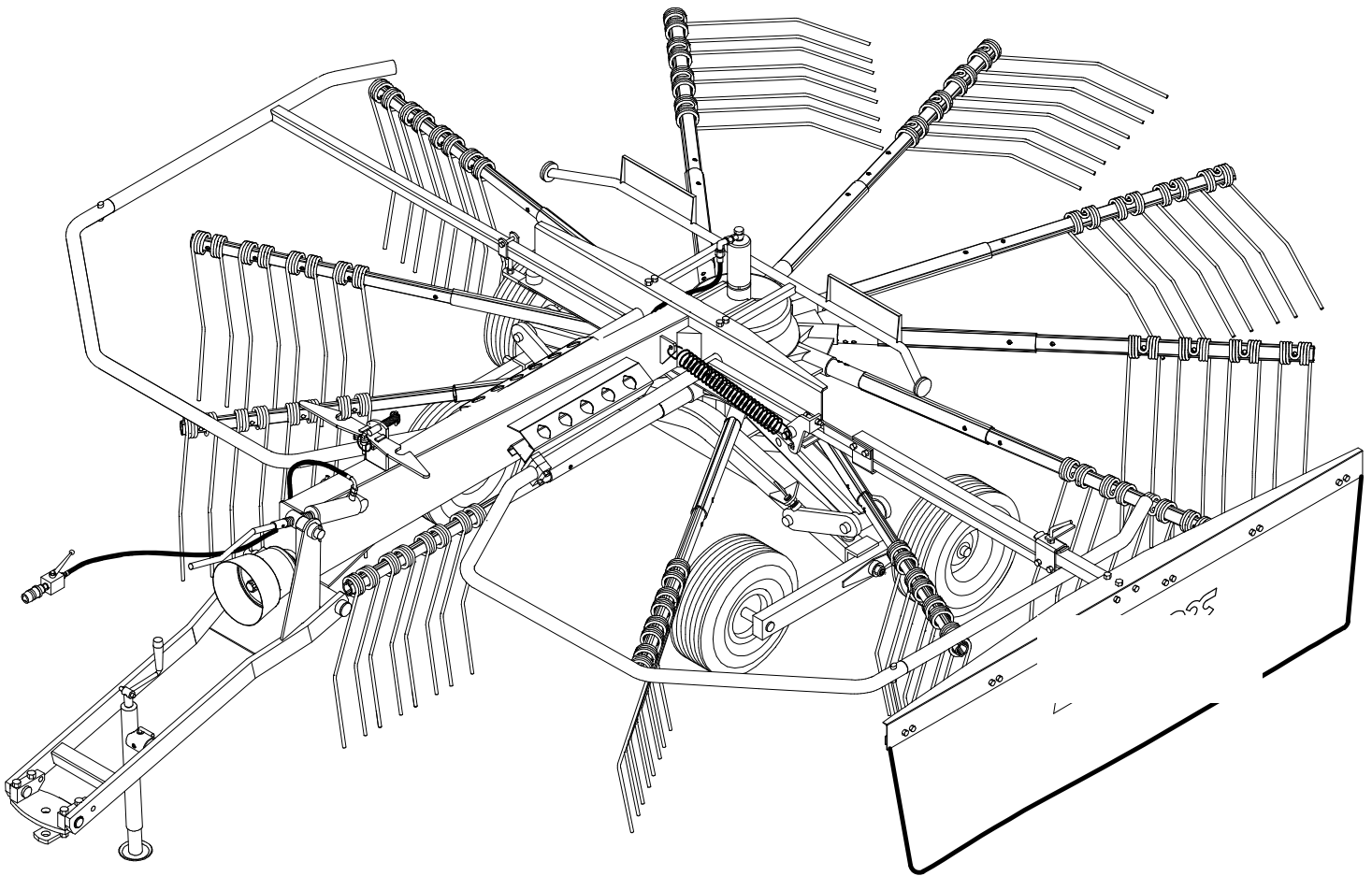

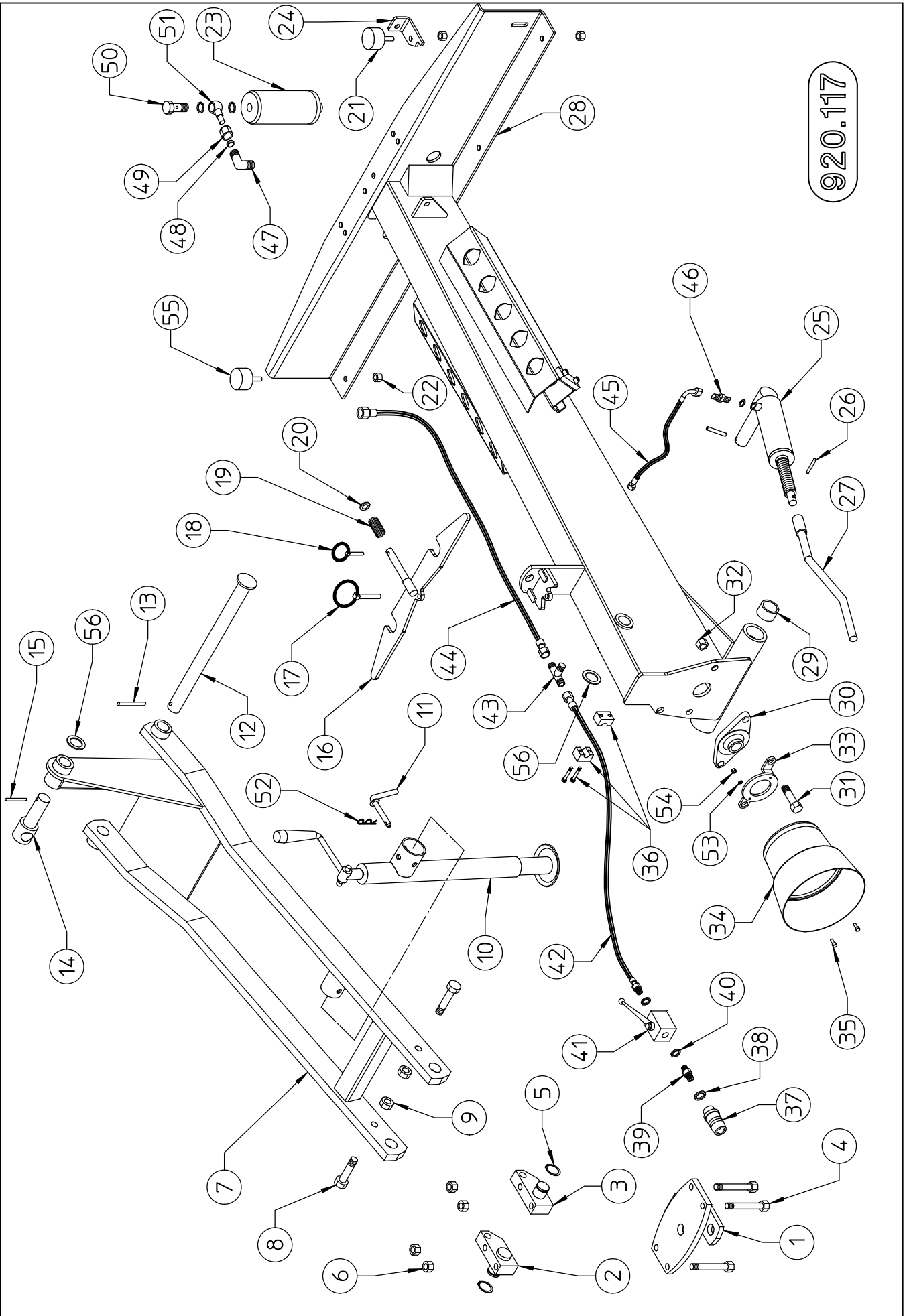

TABLE NO. 920.117				
420/11 Pull type				
ITEM	Q.ty	PART/NO	DESCRIPTION	NOTE
1	1	210.677	BRACKET	
2	1	210.719	RH EQUALIZER	
3	1	210.720	LH EQUALIZER	
4	4	600.737	SCREW	
5	2	600.611	SNAP RING	
6	4	600.075	NUT	
7	1	210.514	DRAWBAR	
8	2	600.292	SCREW	optyonal
9	2	600.080	NUT	optyonal
10	1	200.203	PARKING STAND	
11	1	200.222	PIN	
12	1	210.678	HINGE PIN	
13	1	600.027	SPRING PIN	
14	1	210.518/a	PIN	
15	2	600.539	SPRING PIN	
16	1	210.504	RATCHET	
17	1	600.017	PIN	
18	1	600.723	SPRING PIN	
19	1	210.558	SPRING	
20	1	600.031	WASHER	
21	3	610.283	RUBBER PAD	
22	8	600.008	NUT	
23	1	210.727	CYLINDER	
*	1	610.523	SET OF GASKET	
24	1	210.615	PLATE	
25	1	210.721/a	CYLINDER	
*	1	600.643	SET OF GASKET	
26	1	600.580	SPRING PIN	
27	1	210.722	CRANK	
28	1	210.513	FRAME	
29	2	210.761	BUSH	
30	1	610.285	BEARING	
31	2	610.167	SCREW	
32	2	600.080	NUT	
33	1	210.675	SUPPORT	
34	1	600.818	HOOD	
35	2	600.236	SCREW	
36	3	610.515	HOSE COLLAR	
*	*	210.726/a	HYDRAULIC KIT	
37	1	600.273	RAPID COUPLING	
38	1	600.269	COPPER WASHER	
39	1	600.416	NIPPLE	
40	5	600.039	WASHER	
41	1	610.002	VALVE	
42	1	610.494	HOSE	
43	1	600.272	FITTING	
44	1	610.492	HOSE	
45	1	610.493	HOSE	
46	1	600.270	NIPPLE	
47	1	610.512	NIPPLE	
48	1	610.513	GASKET	
49	1	610.514	NUT	
50	1	600.040	FITTING	
51	1	610.511	IRON PIPE	
52	1	600.019	SPLIT PIN	
53	2	600.412	WASHER	
54	2	600.532	NUT	
55	1	610.521	RUBBER PAD	
56	2	100.141	SHIM	

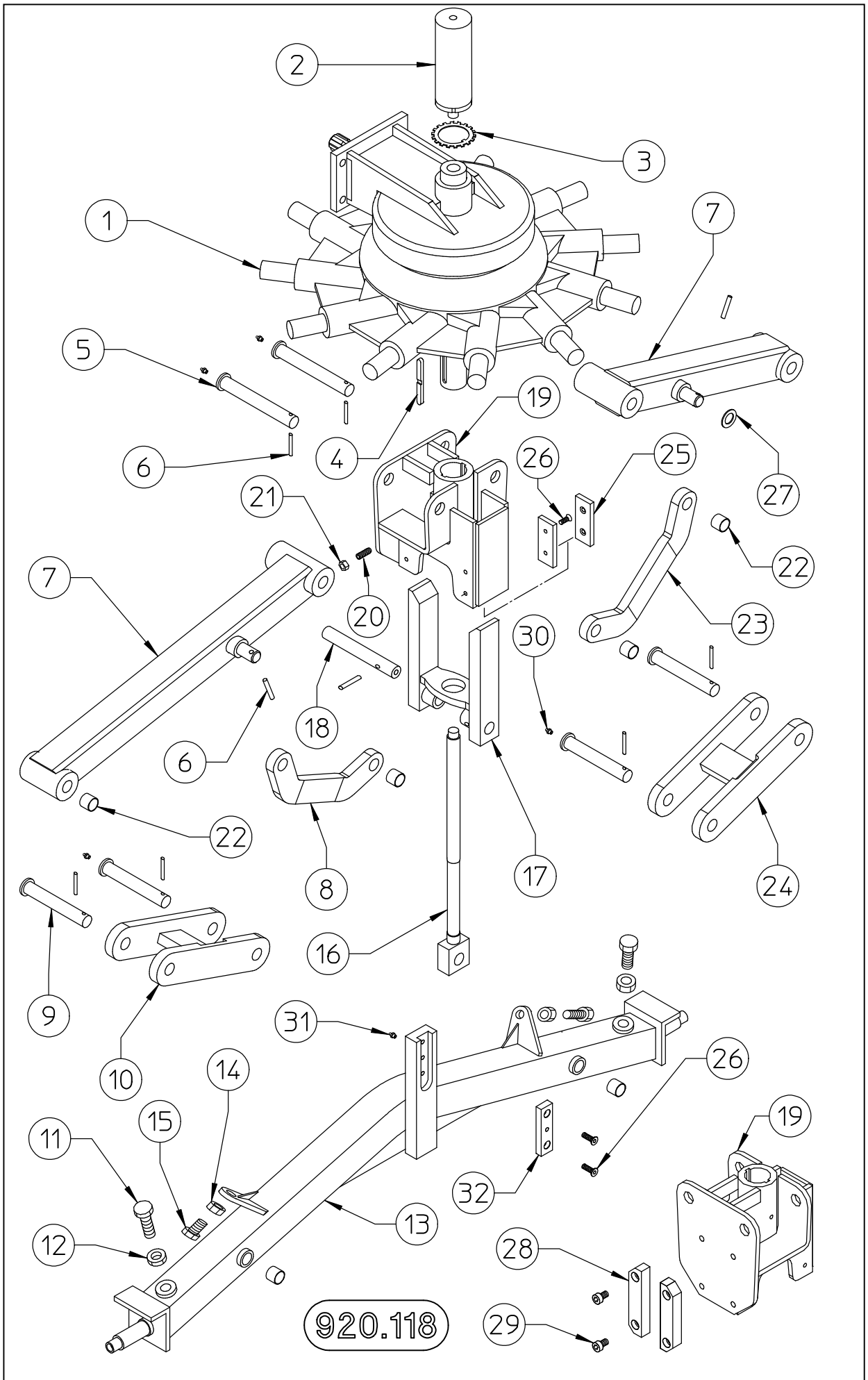
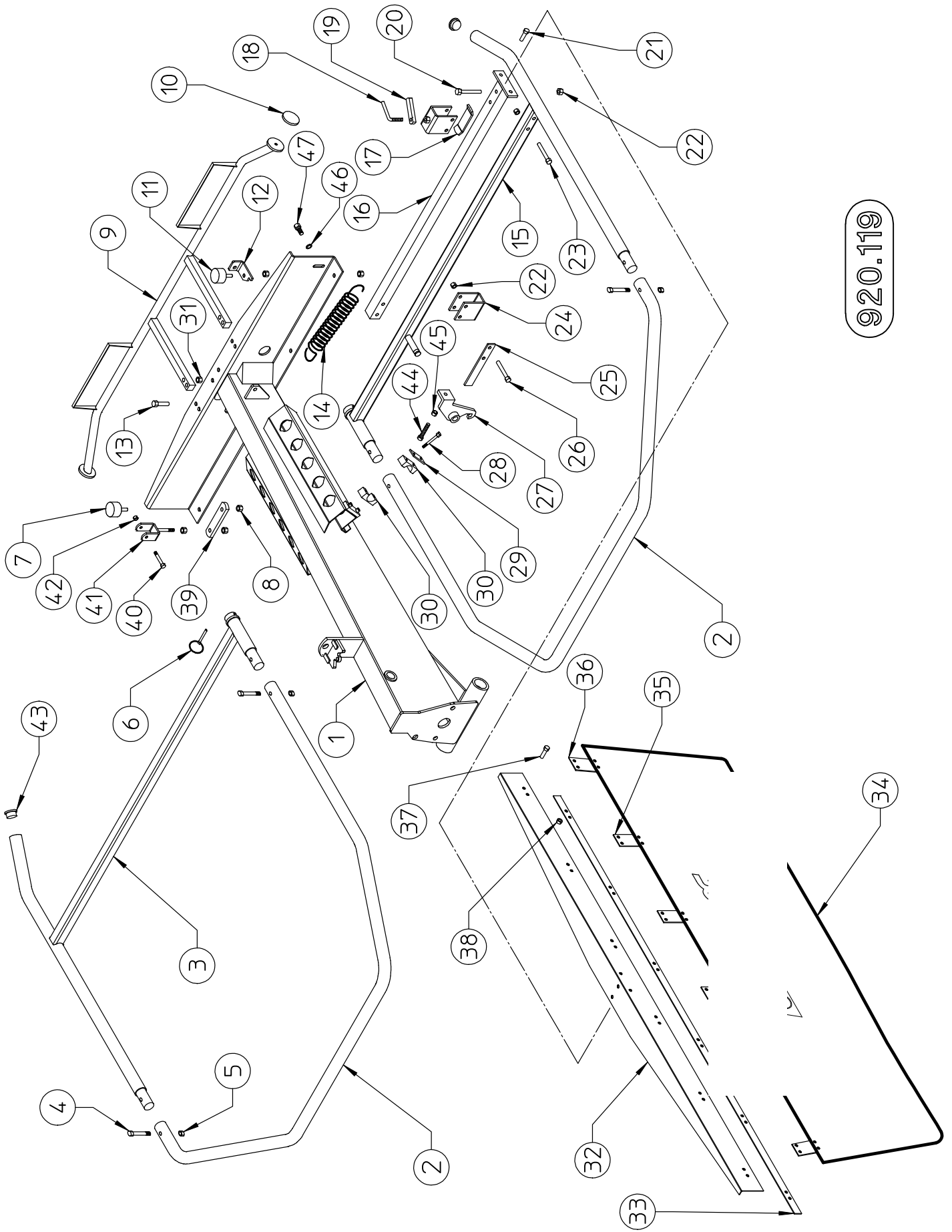
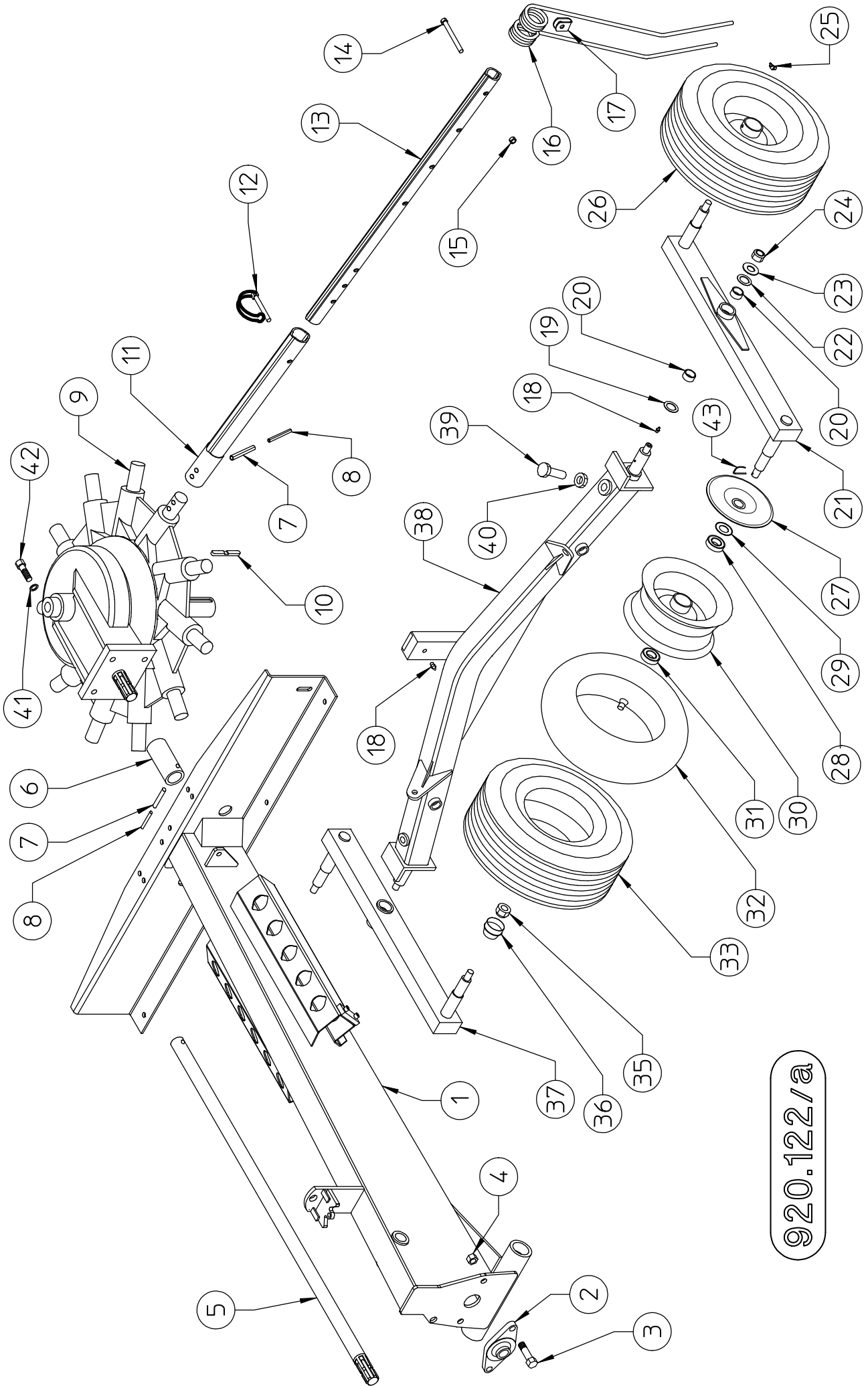

TABLE NO. 920.118				
420/11 Pull type				
ITEM	Q.ty	PART/NO	DESCRIPTION	NOTE
1	1	610.487	GEARBOX	
2	1*	210.727	CYLINDER	
3	2	8.3.8.00336	WASHER	
4	2	210.808	LATCH	
5	2	210.741	PIN	
6	9	600.108	SPRING PIN	
7	2	210.723	ARM	
8	1	210.682	TIEROD	
9	4	210.742	PIN	
10	1	210.762	LH SUPPORT	
11	2	610.497	SCREW	
12	2	600.257	NUT	
13	1	210.725/a	AXLE	
14	2	600.032	NUT	
15	2	610.167	SCREW	
16	1	210.680/a	ROD	
17	1	210.681	SUPPORT	
18	1	210.686/a	PIN	
19	1	210.679/b	SUPPORT	
20	2	610.586	SCREW	
21	2	600.772	NUT	
22	16	610.488	BUSH	
23	1	210.682	TIEROD	
24	1	210.724	RH SUPPORT	
25	4	210.729/a	SLIDING	
26	10	610.496	SCREW	
27	2	100.043	WASHER	
28	2	210.728/a	SLIDING	
29	4	610.503	SCREW	
30	7	600.034	GREASE NIPPLE	
31	1	600.124	GREASE NIPPLE	
32	1	210.939	SLIDING	



920.119

TABLE NO. 920.119				
420/11 Pull type				
ITEM	Q.ty	PART/NO	DESCRIPTION	NOTE
1	1*	210.513	FRAME	
2	2	220.623	GUARD	
3	1	220.622	RH GUARD SUPPORT	
4	4	600.437	SCREW	
5	4	600.029	NUT	
6	2	610.186	PIN	
7	1*	610.521	RUBBER PAD	
8	10*	600.008	NUT	
9	9	210.511	LIGHTING BRACKET	
10	2	610.289	REFLECTOR	
11	3*	610.283	RUBBER PAD	
12	1*	210.615	PLATE	
13	4	600.154	SCREW	
14	1	210.557	SPRING	
15	1	220.621	LH GUARD SUPPORT	
16	1	220.624	TELESCOPING TUBE	
17	1	210.512	PLATE	
18	1	210.502	PIN	
19	1	210.552	NUT	
20	2	600.437	SCREW	
21	2	600.006	SCREW	
22	8	600.029	NUT	
23	4	610.500	SCREW	
24	2	210.498	U-BRACKET	
25	1	210.553	PLATE	
26	2	600.726	SCREW	
27	1	210.554	HOOK	
28	4	610.333	SCREW	
29	2	610.491	PLATE	
30	4	610.332	HOSE COLLAR	
31	4	600.077	NUT	
32	1	210.508	SWATHING SUPPORT	
33	1	210.509	CLAMPING STRAP	
34	1	210.510	SWATHING DEFLECTOR	
35	4	210.555	CLAMPING STRAP	
36	2	210.556	CLAMPING STRAP	
37	12	600.223	SCREW	
38	12	600.076	NUT	
39	1	210.809	PLATE	
40	1	610.525	SCREW	
41	1	210.810	SUPPORT	
42	1	600.076	NUT	
43	2	610.501	PLUG	
44	1	610.499	SCREW	
45	1	600.010	NUT	
46	1	600.089	WASHER	
47	1	600.770	SCREW	



920.122/a

TABLE NO. 920.122/a				
420/11 Pull type				
ITEM	Q.ty	PART/NO	DESCRIPTION	NOTE
1	1*	210.513	FRAME	
2	1*	610.285	BEARING	
3	2*	610.167	SCREW	
4	2*	600.080	NUT	
5	1	210.525	SHAFT	
6	1	210.528	BUSH	
7	23	610.417	SPRING PIN	
8	23	610.419	SPRING PIN	
9	1*	610.487	GEARBOX	
10	2*	210.808	LATCH	
11	11	210.494	PROFILE TUBE	
12	11	600.842	PIN	
13	11	210.493	TINE ARM	
14	44	600.386	SCREW	
15	44	600.077	NUT	
16	44	210.495	TINE	
17	44	200.349	TINE LOCK, FLEXIBLE	
18	3	600.124	GREASE NIPPLE	
19	2	200.272	SHIM	
20	4	600.808	BUSHING	
21	1	210.941	TANDEM ARM	
22	6	200.273	SHIM	
23	2	200.165	WASHER	
24	2	600.079	NUT	
25	4	600.968	GREASE NIPPLE	
26	4	610.677	TYRE ASSY	
27	4	210.942	DUST COVER, INNER	
28	4	600.287	BEARING	
29	4	610.672	DUST COVER	
30	4*	610.683	RIM	
31	4	600.287	BEARING	
32	4*	610.527	TUBE	
33	4*	610.528	TYRE	
34				
35	4	600.288	NUT	
36	4	600.290	DUST COVER, OUTER	
37	1	210.941	TANDEM ARM	
38	1*	210.725/a	AXLE	
39	2	610.497	SCREW	
40	2	600.257	NUT	
41	4	600.180	WASHER	
42	4	600.044	SCREW	
43	4	600.291/1	PIN	

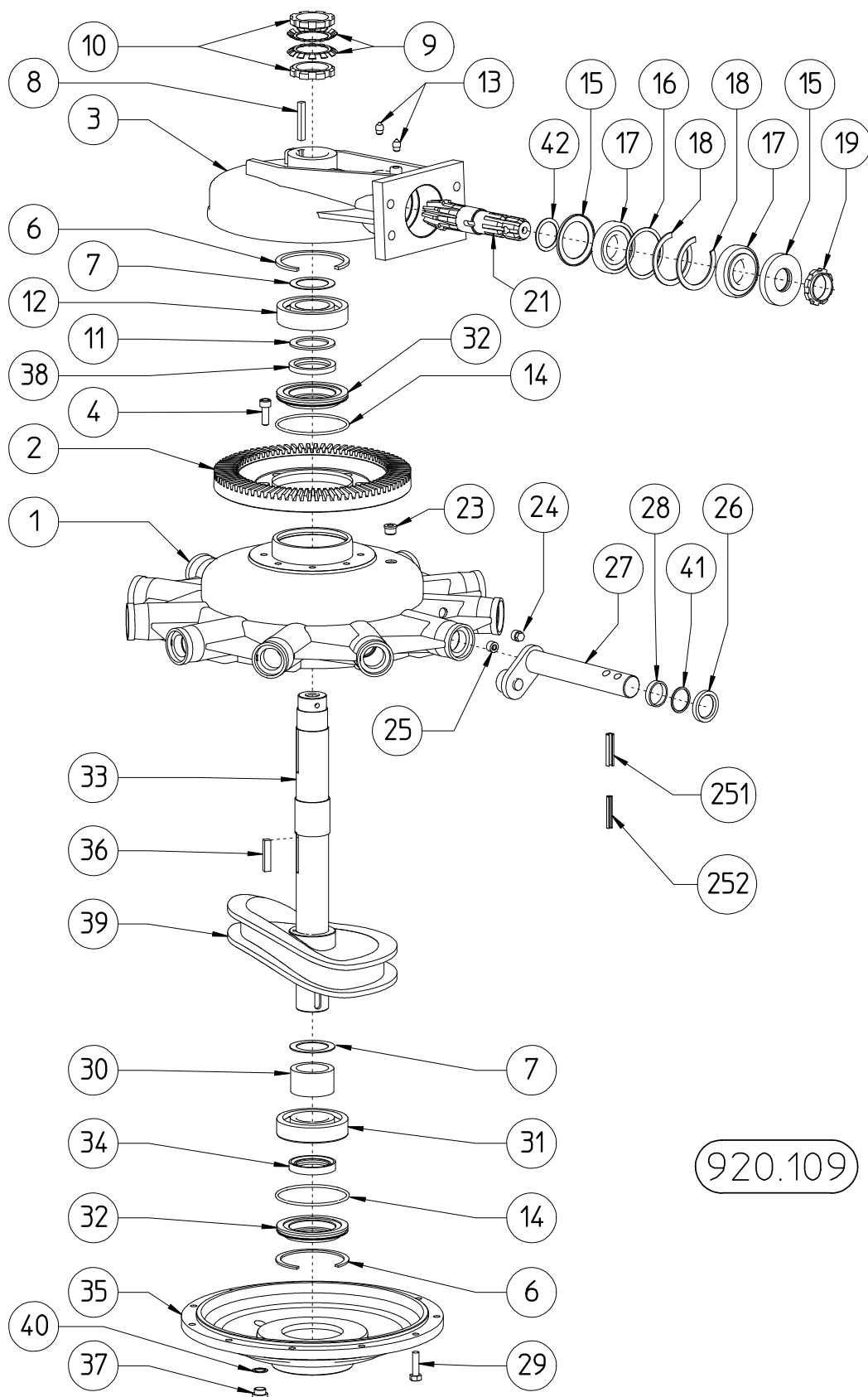

920.109

TABLE NO 920.109				
ITEM	PART NO	Q.ty	DESCRIPTION	NOTE
1	220.732	1	GEAR BOX	
2	220.721	1	GEAR	
3	220.722	1	CAP	
4	220.723	8	SCREW	
6	620.177	2	SNAP RING	
7	220.724	3	SHIM	
8	620.178	1	LATCH	
9	620.179	2	WASHER	
10	620.180	2	NUT	
11	220.733	1	SHIM	
12	620.127	1	BEARING	
13	620.182	2	GREASE NIPPLE	
14	620.163	2	GASKET	
15	620.140	2	DUST COVER	
16	220.726	1	SHIM	
17	620.181	2	BEARING	
18	620.148	2	SNAP RING	
19	220.727	1	REGISTER NUT	
21	220.715	1	PINION	
23	620.151	1	PLUG	
24	620.183	1	PLUG	
25	620.184	1	PLUG	
26	620.162	11	DUST COVER	
27	220.720	11	ARM	
28	220.707	11	SPACER	
29	220.731	11	SCREW	
30	220.717	1	SPACER	
31	620.185	1	BEARING	
32	220.712	2	DUST COVER SUPPORT	
33	220.713	1	SHAFT	
34	620.158	1	DUST COVER	
35	220.728	1	CAP	
36	620.178	1	LATCH	
37	620.153	1	PLUG	
38	620.157	1	DUST COVER	
39	220.711	1	CAM	
40	620.175	1	WASHER	
41	220.718	11	SHIM	
42	220.729	1	SHIM	
251	620.142	22	SPRING PIN	
252	620.144	22	SPRING PIN	

CARDAN SHAFT 610.489

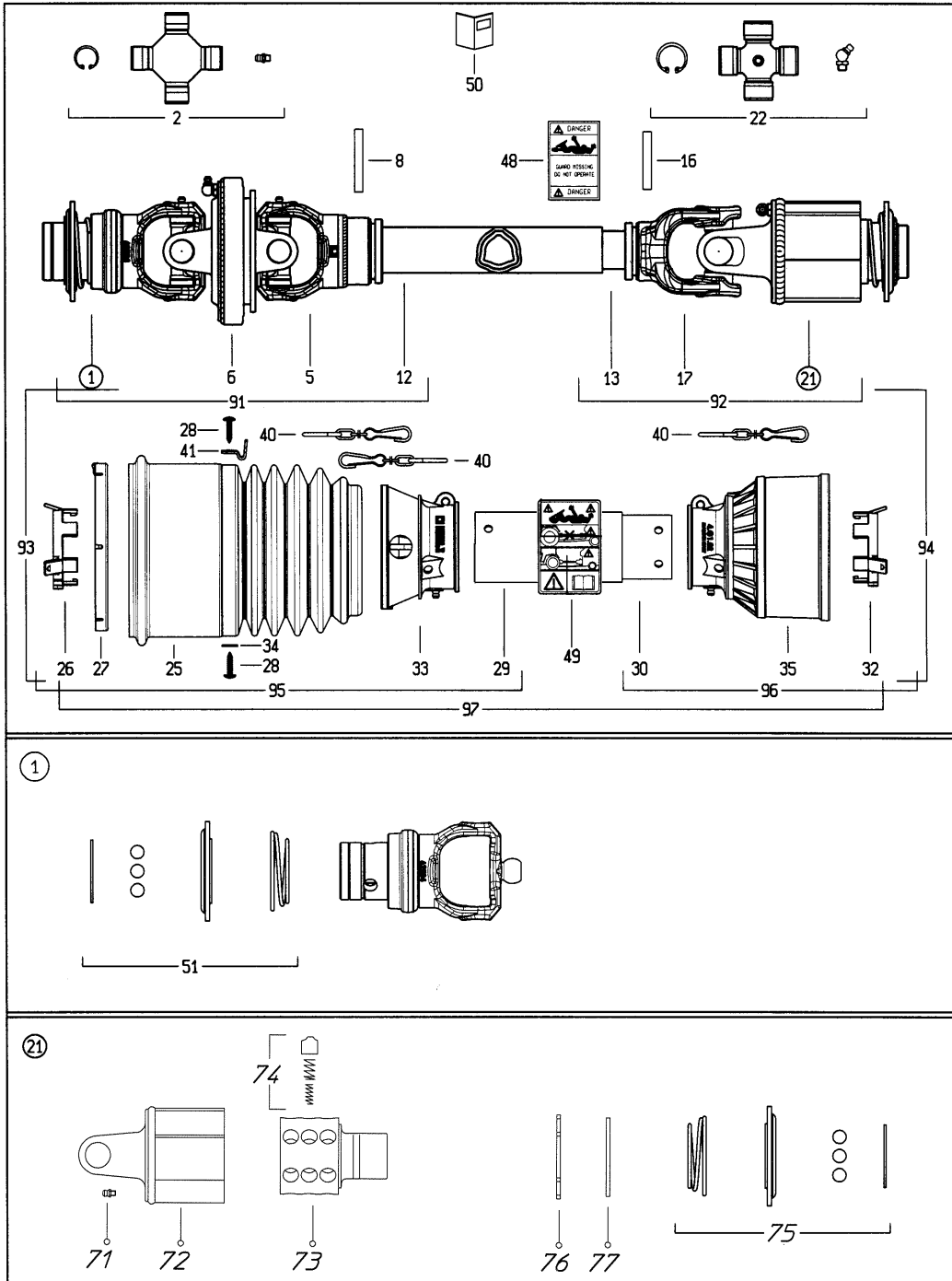

CARDAN SHAFT 610.489			
ITEM	PART NO	Q.ty	DESCRIPTION
1	620.381	1	YOKE
2	620.382	1	CROSS JOURNAL ASS.
5	620.383	1	YOKE
6	620.384	1	CENTER BODY
8	610.548	1	SPRING PIN
12	610.549	1	TUBE
13	610.550	1	TUBE
16	610.551	1	SPRING PIN
17	620.387	1	YOKE
21	620.421	1	TORQUE
22	620.389	1	CROSS JOURNAL ASS.
25	620.390	1	CONE
26	610.557	1	CLIP
27	620.391	1	RING
28	620.392	6	SCREW
29	610.559	1	TUBE
30	610.560	1	TUBE
32	610.562	1	CLIP
33	620.395	1	BASIC CONE
34	620.396	5	WASHER
35	610.561	1	BASIC CONE
40	620.398	3	CHAINE
41	620.399	1	CHAINE HOOK
48	620.400	1	LABEL
49	620.444	1	LABEL
50	620.445	1	MANUAL
51	620.427	1	COMPLETE PUSHING
71	620.411	1	GREASE NIPPLE
72	610.569	1	BODY
73	620.412	1	HUB
74	620.413	18	BUTTON
75	620.414	1	COMPLETE PUSHING
76	610.573	1	REATING WASHER
77	610.574	1	CIRCLIP
91	620.446	1	HALF SHAFT (WITHOUT GUARD)
92	610.576	1	HALF SHAFT (WITHOUT GUARD)
93	620.447	1	HALF SHAFT (WITH GUARD)
94	620.448	1	HALF SHAFT (WITH GUARD)
95	620.449	1	HALF SAFETY GUARD
96	620.450	1	HALF SAFETY GUARD
97	620.451	1	SAFETY GUARD

H&S MANUFACTURING CO. INC.

2608 S. Hume Ave.

P.O. Box 768 - Telephone (715) 387-3414

FAX Number (715) 384-5463

MARSHFIELD, WI 54449

