



560/660 MANURE SPREADER

OPERATOR'S MANUAL



WARNING

READ AND UNDERSTAND THIS MANUAL BEFORE OPERATING THIS EQUIPMENT. UNSAFE OPERATION OR MAINTENANCE OF THIS EQUIPMENT CAN RESULT IN SERIOUS INJURY OR DEATH.

Revision #03

560 Starting Serial #210086

660 Starting Serial #210046

HSMFG0312

Part #72236

Manufactured By
H&S MANUFACTURING CO.,INC.

P.O. BOX 768 (715) 387-3414 FAX (715) 384-5463
MARSHFIELD, WISCONSIN 54449

CONTENTS

Warranty & Warranty Registration Card	1-2
Dealer Pre-Delivery Checklist	3
Dealer Delivery Checklist	5
Safety Information - Be Alert Symbol	7
Safety Information - Explanation of Safety Signs	8
Safety Decals	9-10
Safety Information - Warning - Owner Must Read and Understand	11
Cap Screw Torque Values	12
Set-Up & Assembly	13
Transporting	13
Preparing For Operation	14-15
Operation	16
Adjustments	17-18
Service	19-20
Optional Equipment	21
Lubrication Guide	22-24
Decal Location	25-28
Trouble Shooting	29
Service Notes	30
Specifications	Inside Back Cover

WARRANTY

H&S WARRANTY

H&S Manufacturing Co., Inc. ("H&S") warrants this product to be free from defect in material and workmanship. Except as noted below, this warranty term is twelve (12) months from the date of delivery of the product to the original purchaser by an authorized H&S dealer. Under this warranty, H&S will repair or replace, at its option, any covered part which is found to be defective in material or workmanship during the applicable warranty term. In no case will the covered repair cost of a part or parts exceed the replacement cost of that part. Warranty service must be performed by H&S or a dealer authorized by H&S to sell and/or service the product involved, which will use only new or remanufactured parts or components furnished by H&S. This warranty includes approved parts and labor to fix the product but does not include, and the purchaser is responsible for, any service call and/or transportation of the product to and from the dealer's place of business, for any premium charged for overtime labor requested by the purchaser, and for any service work not directly related to any defect covered under this warranty. This warranty includes only those components of the product manufactured by H&S. Warranty for any component not manufactured by H&S including, but not limited to, engines, batteries, tires, rims, hydraulic motors, pumps, etc. are covered by the warranty, if any, provided separately by their respective manufacturers.

This warranty in all its parts, is extended solely to the original purchaser of the product, is terminated upon any subsequent transfer or sale from or by the original purchaser and extends no third party benefits or rights whatsoever.

The warranty term for any product used in any commercial, custom, for hire or rental application, is limited to six (6) months from the date of delivery of the product to the original purchaser or the first day of service, whichever comes first, by an authorized H&S dealer.

Floor and side panels utilized in H&S Manure Spreaders are warranted, to the original purchaser, to not wear through or delaminate for 10 years when used to spread normal agricultural manure. The frame, sides, end, floor and roof of forage boxes are warranted to not wear or rust through for 10 years when the forage box is used to transport freshly chopped forage. These specific warranties include only replacement of any defective panel part without any allowance for labor beyond the terms of the standard H&S 12 month warranty.

For commercial, custom for hire, or rental application, warranty is limited to 6 months from the date of delivery to the original purchaser, or the first day in service, whichever is earlier.

This warranty does not include: (1) Any product that has been altered or modified in ways not approved by H&S; (2) Depreciation or damage caused by normal wear, misuse, improper or insufficient maintenance, improper operation, accident or failure to follow the product Operator's Manual recommendations and product decal recommendations; (3) Normal maintenance parts and service; (4) Repairs made with parts other than those available from H&S or performed by anyone other than H&S or a dealer authorized by H&S to sell and/or service the product involved.

To secure warranty service the purchaser must report the product defect to a dealer authorized by H&S to sell and/or service the product involved within the applicable warranty term together with evidence of the warranty start date and make the product available to that dealer within a reasonable period of time.

HERE ARE NO WARRANTIES WHICH EXTEND BEYOND THE DESCRIPTION ON THE FACE OF THIS WARRANTY. H&S and the companies affiliated with it makes no warranties, representations, or promises, express or implied, as to the performance or freedom from defect of its products other than those set forth above and **NO IMPLIED WARRANTY OF MERCHANTABILITY, FITNESS OR FITNESS FOR A PARTICULAR PURPOSE IS MADE. IN NO EVENT WILL THE DEALER, H&S OR ANY COMPANY AFFILIATED WITH H&S BE LIABLE FOR INCIDENTAL OR CONSEQUENTIAL DAMAGES.** The **ONLY REMEDY** the purchaser has in connection with the breach of performance of any warranty on H&S products are those set forth above.

The selling dealer has no authority to make any representation or promise on behalf of H&S, or to modify the terms or limitations of this warranty in any way.

12/13

**FILL OUT
AND MAIL
IMMEDIATELY
TO MAKE
WARRANTY
EFFECTIVE**



WARRANTY REGISTRATION

Date of Purchase _____

Purchaser _____ Address _____

City _____ State _____ Zip _____

Product _____ Model# _____ Serial# _____

Dealer _____ Address _____

City _____ State _____ Zip _____

Signature of Original Buyer

MANUFACTURER'S STATEMENT

Your New H&S Product has been manufactured of the finest quality materials and components. The performance you get from your machine is largely dependent upon how well you read and understand this manual and apply this knowledge. There is a right and a wrong way to do everything. Please do not assume that you know how to operate and maintain your Machine before reading this manual carefully. Keep this manual available for ready reference.

IMPORTANT!

Tear on the dotted line, provide the information requested on the card. The H&S Warranty is valid "**only**" after this card is received and recorded at H&S Manufacturing Co., Inc. Mail at once. No postage is required in the U.S.A.



NO POSTAGE
NECESSARY
IF MAILED
IN THE
UNITED STATES

BUSINESS REPLY MAIL

FIRST CLASS MAIL Permit No.195 Marshfield, WI 54449

POSTAGE WILL BE PAID BY ADDRESSEE

H&S Manufacturing Co., Inc.
PO Box 768
Marshfield, WI 54449-9963



DEALER PRE-DELIVERY CHECK LIST

AFTER COMPLETION, DEALER SHOULD REMOVE AND RETAIN FOR RECORDS

After the Manure Spreader has been completely set-up, check to be certain it is in correct operating order before delivering to the customer. The following is a list of points to inspect. Check off each item as you have made the proper adjustments and found the item operating satisfactorily.

- Manure spreader was not damaged in shipment. Check for dents and loose or missing parts. Report damage immediately to H&S Manufacturing Co., Inc.
- All bolts and fasteners are tight.
- Manure spreader has been correctly assembled according to instructions in this manual.
- All grease fittings have been lubricated. Gearbox is filled to proper level.
- Hoses and fittings are properly attached and there are no visible leaks.
- Guards and shields are secure.
- Wheels are properly mounted to torque specifications.
- Tires are inflated to correct pressure.
- Drive chain tension and alignment is correct.
- Decals are in place and legible.
- Main apron chains are adjusted properly.

Connect the manure spreader onto a proper horsepower tractor and attach the PTO and connect the lights. Connect the hydraulic hoses to the tractor remote outlets. Run the manure spreader and make sure all components operate properly.

- PTO guard turns freely.
- Hydraulic end gate operates smoothly.
- Main apron operates smoothly.
- Hydraulic system does not leak under pressure.
- Lights and wiring functioning properly.
- Implement and all components are functioning properly.

Model Number _____ Serial # _____

Dealer's Name _____

Inspection Date _____

Signature of Pre-Delivery Inspector _____

(Remove Dealer File Copy At Perforation)

Intentionally Left Blank

DEALER DELIVERY CHECK LIST

AFTER COMPLETION, DEALER SHOULD REMOVE AND RETAIN FOR RECORDS

This check list that follows is an important reminder of valuable information that should be passed on to the customer at the time this Manure Spreader is delivered.

Check off each item as you explain it to the customer.

This delivery check list, when properly filled out and signed assures the customer that the Pre-delivery service was satisfactorily performed.

- Explain to the customer that the pre-delivery inspection was made.
- Explain to the customer all the safety precautions they must exercise when operating this unit.
- Explain recommended loads for different types of materials.
- Explain to customer that regular lubrication is required for proper operation and long life of machine.
- Show customer the lubrication section of Owner's Manual.
- Give the customer Owner's Manual and make sure they read and understand all operating and service instructions.
- Have the customer sign a completed "Warranty Registration", and mail it.

Date Delivered _____

Dealer's Name _____

By _____

Signature of Original Buyer _____

Note: Warranty is not valid until warranty card is completed and returned to H&S Mfg. Co., Inc.

Intentionally Left Blank

SAFETY INFORMATION



**BE
ALERT!**

**YOUR SAFETY
IS INVOLVED.**

THIS SYMBOL IS USED THROUGHOUT THIS BOOK WHENEVER YOUR PERSONAL SAFETY IS INVOLVED. TAKE TIME TO BE CAREFUL. REMEMBER: THE CAREFUL OPERATOR IS THE BEST OPERATOR. MOST ACCIDENTS ARE CAUSED BY HUMAN ERROR. CERTAIN PRECAUTIONS MUST BE OBSERVED TO PREVENT THE POSSIBILITY OF INJURY OR DAMAGE.

H&S MANUFACTURING CO., INC.

SAFETY INFORMATION

Keep signs in good condition. Immediately replace any missing or damaged signs.

RECOGNIZE SAFETY INFORMATION

This is the safety-alert symbol. When you see this symbol on your machine or in this manual, be alert to the potential for personal injury.

Follow recommended precautions and safe operating practices.



UNDERSTAND SIGNAL WORDS

A single word; DANGER, WARNING, or CAUTION is used with the safety-alert symbol. DANGER identifies the most serious hazards.



Safety signs with signal word DANGER or WARNING are typically near specific hazards.



WARNING

General precautions are listed on CAUTION safety signs.



CAUTION



FOLLOW SAFETY INSTRUCTIONS

Carefully read all safety messages in this manual, and all safety signs on your machine. Follow all recommended precautions and safe operating procedures.

OBSERVE MAXIMUM TRANSPORT SPEED

The maximum transport speed for this implement is 32 km/h (20 m.p.h.).

Some tractors are capable of operating at speeds that exceed the maximum transport speed of this implement. Regardless of the maximum speed capability of the tractor being used to tow this implement, do not exceed the implement's maximum transport speed.

Exceeding the implements maximum transport speed can result in:

- * Loss of control of the tractor/implement combination
- * Reduced or no ability to stop during braking
- * Implement tire failure
- * Damage to the implement structure or its components

Use additional caution and reduce speed when towing under adverse surface conditions, when turning, and when on inclines.

Do not attempt transport if the fully loaded implement weighs more than 1.5 times the weight of the tractor.



SAFETY INFORMATION

	<p style="text-align: center;">⚠ WARNING</p> <p style="text-align: center;">DO NOT OPERATE THIS EQUIPMENT IF THIS DECAL IS EXPOSED. REPLACE SAFETY SHIELDS.</p>
1494A	

	<p style="text-align: center;">⚠ DANGER</p> <p style="text-align: center;">ROTATING DRIVELINE CONTACT CAN CAUSE DEATH KEEP AWAY!</p> <p>DO NOT OPERATE WITHOUT-</p> <ul style="list-style-type: none"> • ALL DRIVELINE, TRACTOR AND EQUIPMENT SHIELDS IN PLACE. • DRIVELINES SECURELY ATTACHED AT BOTH ENDS. • DRIVELINE SHIELDS THAT TURN FREELY ON DRIVELINE.
1494L	

	<p style="text-align: center;">⚠ WARNING</p> <p style="text-align: center;">DO NOT GO NEAR LEAKS</p> <ul style="list-style-type: none"> • High pressure oil easily punctures skin causing serious injury, gangrene or death. • If injured, seek emergency medical help. Immediate surgery is required to remove oil. • Do not use finger or skin to check for leaks. • Lower load or relieve hydraulic pressure before loosening fittings.
11599	

⚠ WARNING		
		
<p style="text-align: center;">CRUSHING HAZARD</p> <p>TO PREVENT SERIOUS INJURY OR DEATH:</p> <p>KEEP HANDS AND BODY OUT OF HITCH AREA WHEN ATTACHING TOWING VEHICLE.</p> <p>KEEP BODY CLEAR OF CRUSH POINT BETWEEN TOWING VEHICLE AND LOAD.</p> <p>KEEP FEET AND LEGS CLEAR FROM UNDER TONGUE AREA IN CASE OF POSSIBLE JACK FAILURE.</p>		
82602		

	<p style="text-align: center;">⚠ WARNING</p> <p style="text-align: center;">DO NOT REMOVE SHIELDS</p> <p style="text-align: center;">ROTATING PARTS INSIDE</p>
12794	

	<p style="text-align: center;">⚠ WARNING</p> <p style="text-align: center;">DO NOT REMOVE SHIELDS</p> <p style="text-align: center;">MOVING PARTS INSIDE</p>
1494B	

	<p style="text-align: center;">⚠ WARNING</p> <p style="text-align: center;">DO NOT OPERATE THIS EQUIPMENT IF THIS DECAL IS EXPOSED. REPLACE SAFETY SHIELDS.</p>
71494A	

SAFETY INFORMATION

! WARNING



DO NOT REMOVE SHIELDS
MOVING PARTS INSIDE

1494K

! DANGER



NO STEP-STAY CLEAR

9194A

! DANGER



NEVER ALLOW RIDERS ON THIS MACHINE

9194B

! WARNING



STAY CLEAR OF END GATE ARMS

123002

! DANGER



STAY CLEAR OF END GATE ARMS

111593C

! DANGER



STAY CLEAR OF BEATER IF TRACTOR OR PTO IS RUNNING
BEATER SHUT OFF COULD ACCIDENTALLY BE ENGAGED

FAILURE TO HEED THIS WARNING MAY RESULT IN PERSONAL INJURY OR DEATH

KEEP CLOTHING, YOURSELF AND OTHERS WELL CLEAR

111593A

! WARNING



DO NOT CLEAN OR WORK ON THIS MACHINE WITHOUT FIRST DISENGAGING POWER AND SHUTTING OFF TRACTOR ENGINE.

1494J

SAFETY INFORMATION

TRACTOR:

This operators manual uses the term “Tractor” when identifying the power or the towing source.



TO PREVENT SERIOUS INJURY OR DEATH

BEFORE YOU ATTEMPT TO OPERATE THIS EQUIPMENT, READ AND STUDY THE FOLLOWING INFORMATION. IN ADDITION, MAKE SURE THAT EVERY INDIVIDUAL WHO OPERATES OR WORKS WITH THIS EQUIPMENT, WHETHER FAMILY MEMBER OR EMPLOYEE, IS FAMILIAR WITH THESE SAFETY PRECAUTIONS.

KNOW HOW TO STOP UNLOADING MECHANISM BEFORE STARTING IT.

If the machine becomes clogged, disengage the PTO. Stop the tractor engine, remove ignition key, and allow all mechanisms to stop before cleaning or working on the machine.

DO NOT get off the tractor while the Manure Spreader is in operation.

DO NOT attempt to perform maintenance or repair with tractor running and PTO or hydraulic lines hooked up.

DO NOT step up on machine at any time.

NEVER manually feed material into the beaters.

DO NOT allow minors to operate or be near the machine.

DO NOT ALLOW PERSONNEL OTHER THAN THE QUALIFIED OPERATOR NEAR THE MACHINE.

Before starting tractor, be sure PTO shields turn freely and PTO is securely locked to tractor.

DO NOT clean, adjust, or lubricate the machine when any part is in operation.

Keep hands, feet, and clothing away from beaters when they are revolving.

Loose or floppy clothing should not be worn by the operator.

Be sure the machine is clear of people, tools, and other objects before engaging PTO.

DO NOT step over power take off shaft. Stay clear of PTO at all times.

NEVER start Manure Spreader until all guards and safety shields are secured in place.

STAY CLEAR of Hydraulic Lines. They may be under extreme pressure or heat.

H&S always takes the operator and his safety into consideration and guards exposed moving parts for his protection. However, some areas cannot be guarded or shielded in order to assure proper operation. In addition, the operators manual and decals on the machine itself warn you of further danger and should be read and observed closely.

Study The Above Safety Rules
ATTENTION - BE ALERT - YOUR SAFETY IS INVOLVED

CAP SCREW TORQUE VALUES

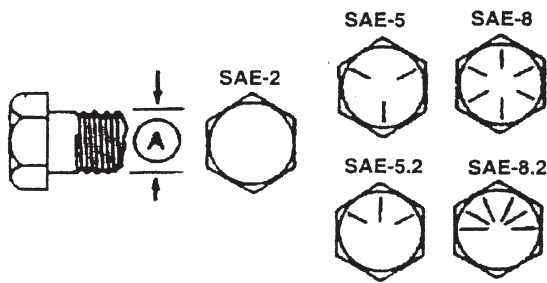

Inch Cap Screw Head Markings

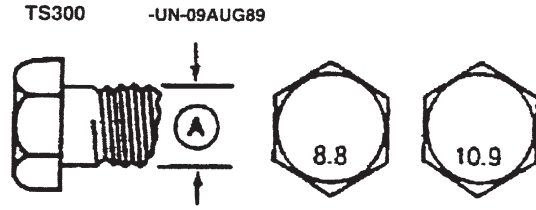

Metric Cap Screw Head Markings

-UN-09AUG89
TS299

INCH CAP SCREW TORQUE VALUES

METRIC CAP SCREW TORQUE VALUES

Bolt Diameter (A)	Wrench Size	Cap Screw Grade					
		SAE 2		SAE 5		SAE 8	
		N-m	lb.-ft	N-m	lb.-ft	N-m	lb.-ft
1/4"	7/16"	7	(5)	11	(8)	16	(12)
5/16"	1/2"	14	(10)	23	(17)	33	(24)
3/8"	9/16"	24	(18)	41	(30)	54	(40)
7/16"	5/8"	41	(30)	68	(50)	95	(70)
1/2"	3/4"	61	(45)	102	(75)	142	(105)
9/16"	13/16"	88	(65)	142	(105)	203	(150)
5/8"	15/16"	122	(90)	197	(145)	278	(205)
3/4"	1-1/8"	217	(160)	353	(260)	495	(365)
7/8"	1-5/16"	224	(165)	563	(415)	800	(590)
1"	1-1/2"	332	(245)	848	(625)	1193	(880)
1-1/4"	1-7/8"	665	(490)	1492	(1100)	2393	(1765)

Bolt Diameter (A)	Wrench Size	Markings on Cap Screw Heads			
		8.8		10.9	
		N-m	lb.-ft	N-m	lb.-ft
5 mm	8 mm	6	(4.5)	9	(6.5)
6 mm	10 mm	10	(7.5)	15	(11)
8 mm	13 mm	25	(18)	35	(26)
10 mm	16 mm	50	(37)	75	(55)
12 mm	18 mm	85	(63)	130	(97)
16 mm	24 mm	215	(159)	315	(232)
20 mm	30 mm	435	(321)	620	(457)
24 mm	36 mm	750	(553)	1070	(789)
30 mm	46 mm	1495	(1103)	2130	(1571)



CAUTION: Use only metric tools on metric hardware. Other tools may not fit properly. They may slip and cause injury.

DO NOT use these values if a different torque value tightening procedure is listed for a specific application. Torque values listed are for general use only. Check tightness of cap screws periodically.

Shear bolts are designed to fail under predetermined loads. Always replace shear bolts with identical grade. Fasteners should be replaced with the same or higher grade. If higher grade fasteners are used, these should only be tightened to the strength of the original.

Make sure fastener threads are clean and you properly start thread engagement. This will prevent them from failing when tightening.

Tighten plastic insert or crimped steel-type lock nuts to approximately 50 percent of amount shown in chart. Tighten toothed or serrated-type lock nuts to full torque value.

SET-UP & ASSEMBLY

Note: Determine right and left side of spreader by viewing it from the rear. If instructions or parts lists call for hardened bolts, refer to Cap Screw Torque Value page to identify.

PREPARING MANURE SPREADER

The Manure Spreader may be shipped without the wheels/tires installed.

1. Attach the wheels with tires, using the lug nuts furnished and torque the mounting hardware to the appropriate torque. The wheel bolts must be tightened at 100 ft./lbs. of torque on the 560, and 300 ft./lbs. of torque on the 660
2. Check the tires and inflate them to the recommended pressure(425/65R-22.5 tires to 85 psi.).
3. Check for proper assembly and adjustment and make sure that all bolts are tightened.
4. Securely retighten after a few hours of operation, as bolts can loosen up on new machinery.
5. Lubricate the machine completely, check the oil level of the gearbox, fill if necessary.

TRANSPORTING

TRANSPORT LIGHTING & REFLECTORS

When transporting on the highway, connect the spreader to the tractor with a lighting power cord. The lighting system is to be connected to the 7 pin power receptacle (per SAEJ560B) on your tractor. If your tractor is not equipped with the proper receptacle, see your tractor dealer for details. Make sure lights are functioning properly. Regularly clean the reflective tape at the rear of the spreader. There is a holder provided for your SMV sign.



SAFETY CHAIN (Optional)

Follow state and local regulations regarding use of a safety chain and transport lighting when towing farm equipment on public highways. A proper safety chain should be used to retain the safety connection between the towing and towed machines, in the event of separation of the primary attaching system. Check with local law enforcement agencies for your own particular regulations. Unless otherwise prohibited, use a slow-moving vehicle emblem. Never tow the manure spreader on a public highway at a speed greater than 20 m.p.h. (32 kph).

1. Chain is sufficiently slack to allow turns and movements of either the tractor or the manure spreader, without placing tension on the chain.
2. Chain is of sufficient strength to hold the decoupled implement (and its load) and tow it to the shoulder.

PREPARING FOR OPERATION

TRACTOR CONNECTIONS

Tractor Hitch

Fasten the spreader hitch to the drawbar with a **hitch pin with a safety locking device**. Remove the weight from the jack (jack is not to be used when spreader is loaded). Remove jack from the pipe mount and place it on the storage mount located on the left front of spreader. This allows protection of the jack from the tractor tires during turns. The hitch of the spreader is designed for a standardized tractor hitch. Adjust the drawbar so that it is 13 to 17 inches above the ground. Extend or shorten it so that the horizontal distance from the end of the tractor power takeoff shaft to the center of the hitch pin hole is 14 inches for 540 PTO and 15-3/4" for 1000 PTO as shown in drawing. An improperly located hitch point may cause damage to the universal joints of the power takeoff. Secure the drawbar so that the hitch pin hole is directly below the power drive line.

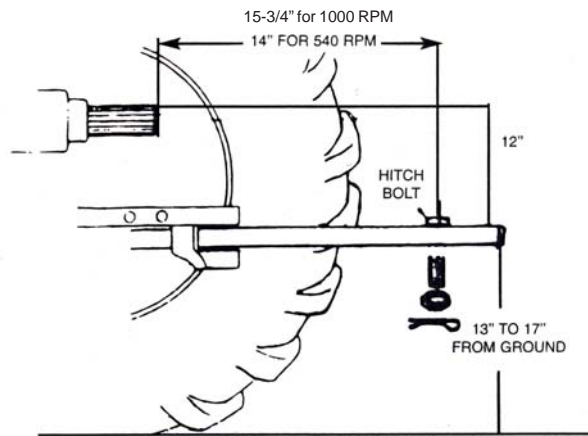

PTO

Attach the PTO of the spreader to the tractor by sliding the spring loaded locking collar on PTO yoke rearward, then sliding it onto the tractor PTO shaft. Release the spring loaded collar. Be sure the pins fall into the groove of the tractor PTO shaft and collar snaps forward into locking position.

CAUTION: Do not use a steel hammer to aid in joining PTO parts.

If this implement is attached to a tractor with a clevis hitch (hammer-strap) style drawbar, the hammer-strap must be removed to prevent damage to the IID guarding and the IID telescoping members. [See Figure 1]

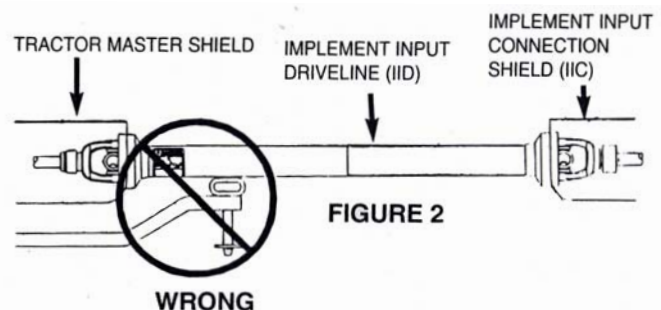
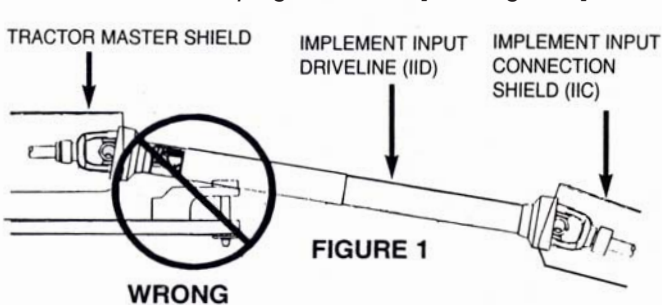

If this implement is attached to a tractor with an offset in the drawbar, be certain it is in the down position to prevent damage to the IID guarding and the IID telescoping members. [See Figure 2]

PREPARING FOR OPERATION

Hydraulics

The spreader requires a 4 hose hook-up;

Connect the set of hydraulic hoses which operate the hydraulic endgate to a double acting valve on the tractor.

Connect the set of hydraulic hoses which operate the spreader main aprons from the spreader to a double acting valve on the tractor.

Securely mount the electrical speed control inside the tractor cab. Attach the pigtail to the tractor electrical supply, either wired directly from the battery, or by connecting to the convenience plug.

Note: The Hydraulic Endgate must always be raised completely prior to activating the hydraulics for the main apron.

Operate the tractor valve to fill the hydraulic lines and operate the cylinders. Add hydraulic fluid to the tractor system, as required.

Before operation, run the machine slowly to make sure that the spreader is operating and lubricated properly.

OPERATION

EMERGENCY SHUTDOWN

If a foreign object becomes lodged in the beater area and shears the shear bolt, disengage the PTO. Stop the tractor engine, remove the ignition key, and allow all mechanisms to stop before cleaning or working on the spreader.



WARNING: Some photographs used in the following pages show guards or shields removed for clarification. NEVER operate machine until these guards or shields are in proper operating position.

LOADING

Begin loading the spreader at the front end and work toward the rear until loading is completed. Loading this way permits the material to be spread uniformly. Loading front to rear is particularly important when the spreader is loaded by a mechanical loader because this type of load requires more power to spread than other loads.

When hauling extremely heavy materials with a large portion of dirt, it may be necessary to reduce the load size to prevent excessive shear bolt breakage. Never dump material onto the beater. Do not use extra sideboards. Do not overload the Manure Spreader. Overloading decreases the spreading effectiveness. Do not load more than 15 inches above the beater.

WINTER OPERATION

In freezing weather, make certain that hydraulic tailgate is not frozen to the sides or on the floor of the spreader. Make sure the push gate is not frozen to the spreader floor or any lumps of manure are frozen to the floor.

SPREADING

1. Engage the tractor PTO slowly. The beater is always in the engaged position, therefore, engaging the tractor PTO will automatically starts the beaters.

2. Raise the hydraulic endgate by engaging the tractor hydraulics.

Note: The Hydraulic endgate MUST BE RAISED COMPLETELY prior to engaging the hydraulic main apron.

3. Engage the tractor hydraulic lever into the detent position to operate the hydraulic drive main aprons.

4. Control the variable speed main apron by using the cab-mounted electric control.

5. When the spreader is almost empty, the box can be cleaned out by disengaging the tractor PTO (which will stop the beater), and increasing the apron speed.

6. When the spreader is completely empty, return the apron speed indicator to the stop position and engage the tractor hydraulics to close the hydraulic endgate.



ADJUSTMENTS

APRON

Tighten the four adjusting bolts (1 on each side of spreader and the two below the input shaft shield) equally so that the apron slats run parallel with the ends of the bed. The apron will be damaged if the machine is operated with one end of the apron slats running ahead of the opposite end.

Adjust the tightener bolts equally on both sides of each apron until (three) slats are lifted off of the apron return slides at the front and rear of the spreader.

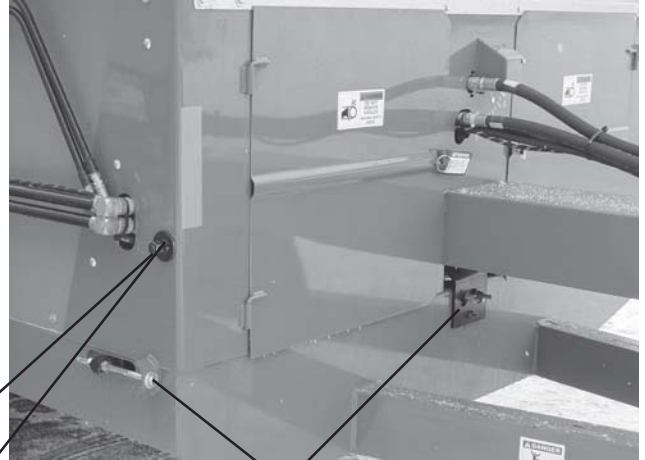

**Front
Drive
Chain
Adjuster**

Apron Tightening Bolts

FRONT DRIVE CHAIN

To adjust the front drive chain, loosen the jam nut and turn the nut on the adjusting rod (located at the right hand front side of spreader) clockwise. There should be 1/2" deflection at the center of the drive chain. Over tightening or too loose of a chain will result in excessive wear on the bearing, chain and sprockets. After adjusting, lock with the jam nut.

APRON DRIVE

Check the apron drive chain regularly. To adjust, loosen the nut on the tightener and slide the tightener against the chain until there is approximately 1/8" deflection in the center of the chain opposite the tightener.

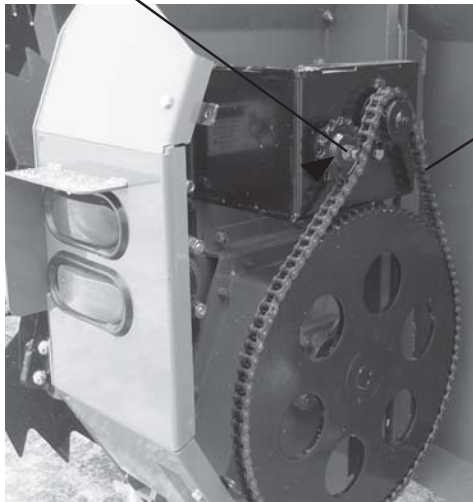

Shields Removed for Clarity

ADJUSTMENTS

PRIMARY & SECOND BEATER DRIVE CHAINS

Both chains are spring loaded. Check both chains regularly to maintain space between the coils of the springs. Adjust the “I” bolt to increase spring tension. If the space between the coils of the spring is not able to be maintained by adjusting the I-bolt, a link may have to be removed in the main aprons to maintain proper adjustment.

NOTE: PERIODICALLY LUBRICATE ALL ROLLER CHAINS WITH A LIGHT MACHINE OIL.



BE SURE ALL SHIELDS ARE SECURED INTO PLACE PRIOR TO RE-STARTING MACHINE.

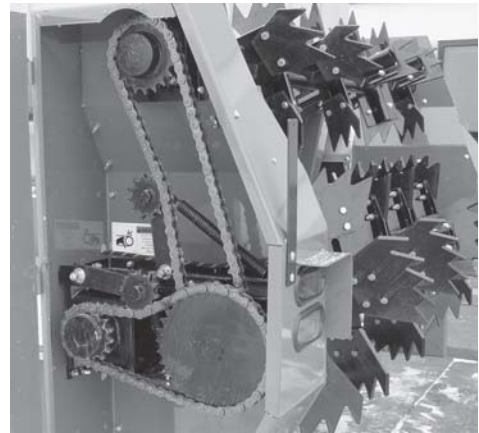

Shields Removed for Clarity

ADJUSTING WHEEL HUBS

To adjust the wheel hubs, tighten the castellated nut on the spindle to the point where there is no end-play and a slight drag on the bearings. Replace the cotter key with a new one of the correct size.

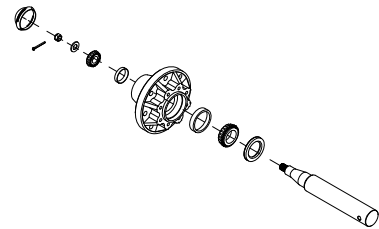

SERVICE

SHEAR BOLT

Both beaters at the rear of the spreader are protected by one shear bolt located in the PTO at the front of the spreader. Four spare shear bolts are provided. Shearing of shear bolts is normally due to large frozen chunks of manure, foreign objects (rocks, chunks of wood, etc.) in the manure, running the apron too fast when unloading long straw and pen-packed material, or **STARTING THE SPREADER PTO TOO QUICKLY WITH HIGH TRACTOR RPM'S**. Always determine the reason for shearing bolt and eliminate the problem before replacing the shear bolt. Always use the proper H&S shear bolts.

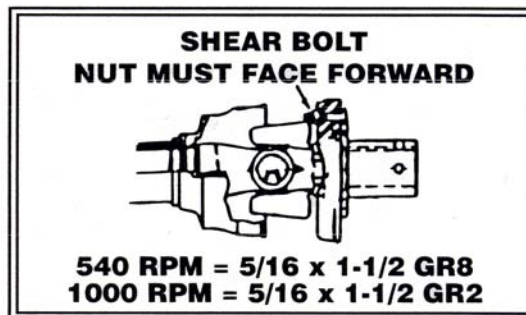
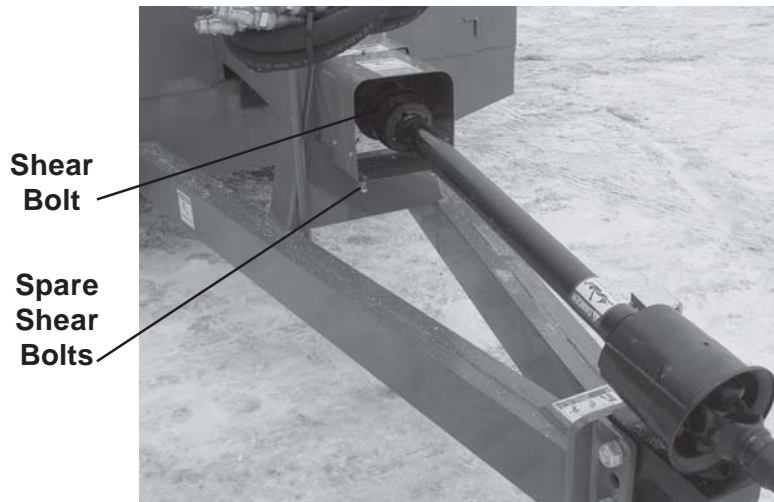

SERVICE

BEATER

When replacing the beater paddles, the sharp edges of the teeth must lead in the direction of beater travel. On the right half of the beater the teeth must point to the right side of the spreader. On the left half of the beater the teeth must point to the left side of the spreader. Always use H&S special grade 5 bolts, washers, and nuts when replacing the tips, and torque to 60 foot lbs.



WHEEL BEARING LUBRICATION, CLEAN & RE-PACK INSTRUCTIONS

Wheel hubs are equipped with a grease zerk for regular maintenance. Annually disassemble and clean parts in solvent. Pack the bearings with grease and reassemble the bearings, tighten the castellated nut on the spindle to the point where there is no end-play and a slight drag on the bearings. Replace the cotter key with a new one of the correct size, bend cotter pin over and re-install cap.

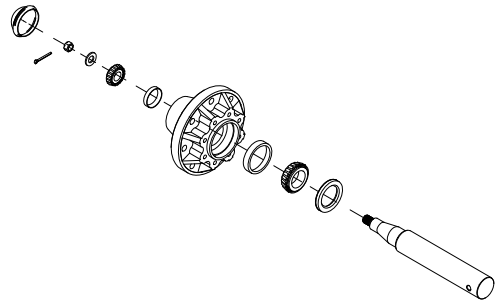

OPTIONAL EQUIPMENT

REAR PAN

The rear pan is optional equipment on the 560 & 660 manure spreaders. The rear pan and hydraulic endgate may be used together on both models.

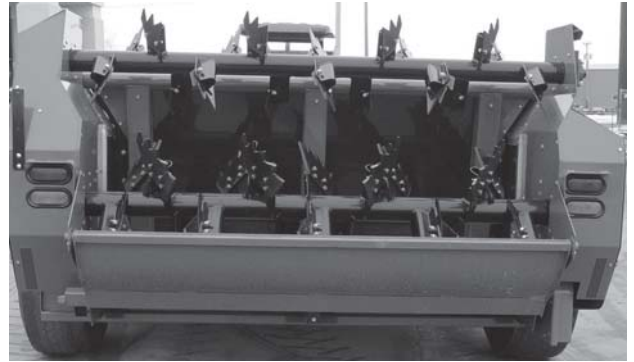

LUBRICATION GUIDE

GENERAL INFORMATION

IMPORTANT: *Catch and dispose of fluid per local waste disposal regulations whenever service is performed on hydraulic components, valves, cylinders, hoses, etc.*

GREASE FITTINGS

There are numerous grease fittings on the spreader. The operator should become familiar with all lubrication points and establish a systematic routine to insure complete and quick lubrication of the machine. If these are lubricated properly and often enough, it will prolong the life of the spreader. (Grease every 10 hours, **also before and after power washing.**) Make certain that the grease fittings are free of paint and dirt, force a high-quality grease into them until the grease comes out around the shaft on the sleeve-type bearings. On the sealed ball bearings, grease should be added slowly until a slight bead forms at the seals indicating the correct amount of lubricant. Wipe off excess grease to prevent the accumulation of chaff and grit around the bearings.

PTO ASSEMBLY

Care must be taken to keep the male and female driving elements well lubricated and free sliding. Failure to observe this precaution will result in excessive pressure being required to collapse or extend the assembly while subject to operating torque. This excessive force may damage or displace the jackshaft bearings. **DO NOT** lubricate the shield surfaces. The shield surfaces must be kept dry, as dirt accumulation on them will quickly cause these units to bind and not rotate. Care should also be taken to be certain that the rotating integral shields are not dented or damaged, as this also will result in excessive force being applied against the jackshaft. Damaged shields also cause obvious difficulties when installing the assembly. If at any time the shields do not turn freely, they should be checked to determine the cause, and repaired or cleaned. To avoid damage to the main drive bearings, avoid turning sharp corners while PTO is running.

Start and Stop PTO slowly to avoid damage to the drive line.

Constant angle applications must have a lube interval of 4 hours.

LUBRICATION REQUIREMENTS

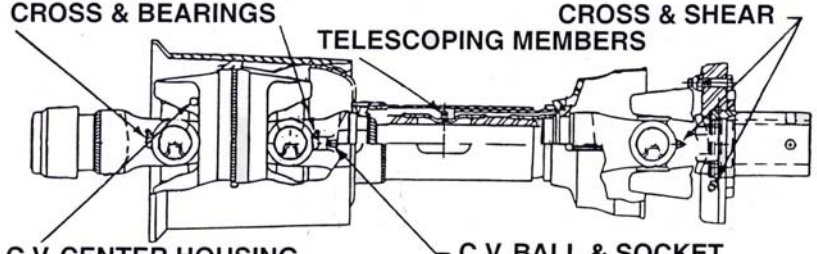

<u>INTERVAL</u>	<u>LOCATION</u>	<u>AMOUNT</u>
8 HRS.*	CROSS & BEARINGS	1-PUMP
8 HRS.	TELESCOPING MEMBERS	4-8 PUMPS
8 HRS.	C.V. BALL & SOCKET	1-2 PUMPS
24 HRS.	C.V. CENTER HOUSING	4-PUMPS

IMPORTANT

DAMAGE WILL OCCUR
IF 80° C.V. JOINT
ANGLE IS EXCEEDED

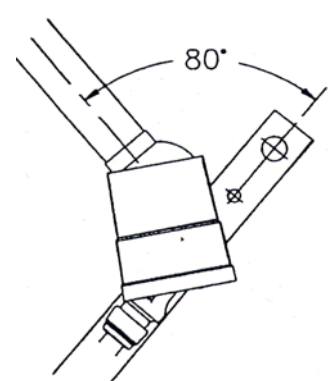

LUBRICATION

GREASE ZERK LOCATION

- A. (7) PTO Shaft
- B. (2) Front jack shaft bearings.
- C. (4) Side Shaft Support Bearings
- D. (2) Endgate Pivot Points
- E. (2) Each Axle Pivot (Remote Zerk)
- F. (4) Each Beater End
- G. (4) Each Front Idler Sprocket
- H. (3) Apron Drive Shaft Support Bearings
- I. (1) Bearing on Apron Reduction

NOTE: Shields removed in some pictures for clarity. **DO NOT OPERATE WITH SHIELDS REMOVED.**

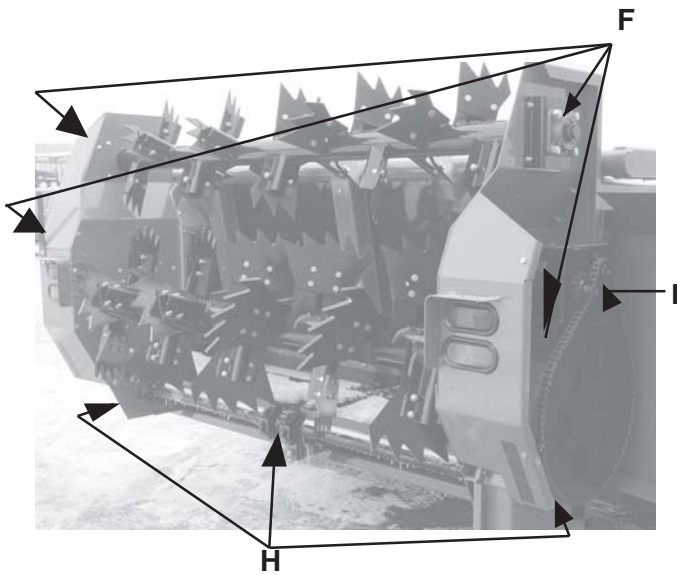

Shields Removed for Clarity

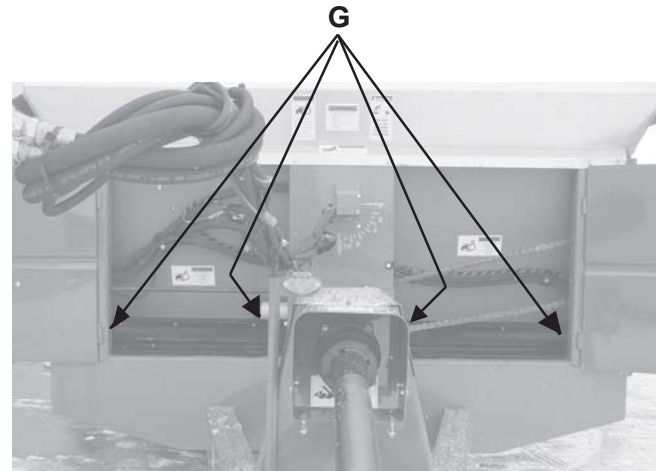

Shields Removed for Clarity

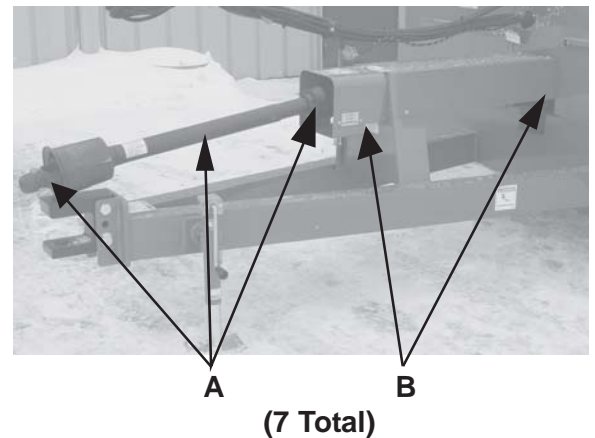
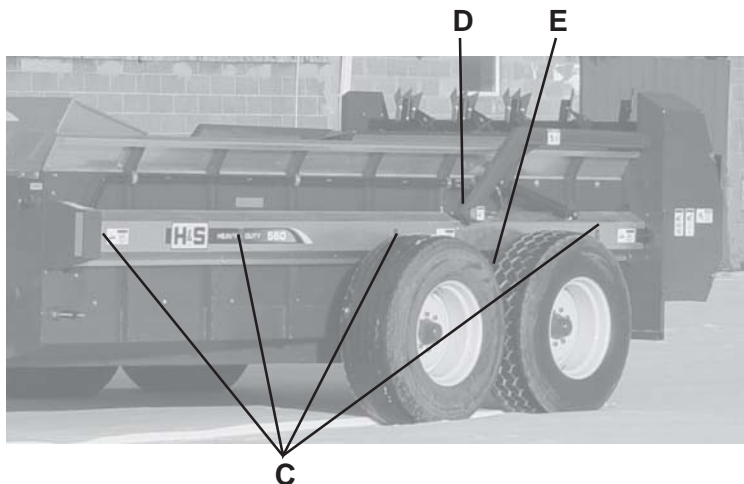

LUBRICATION

GEAR BOX

Before using your new machine, check the oil in the beater drive gearbox (A) and apron chain reduction oil bath (B). Keep the gearbox filled to the oil plug on the side of the gearbox with #80-90 gear lube. Keep a sufficient amount of #80-90 gear lube in the oil bath (B).

B

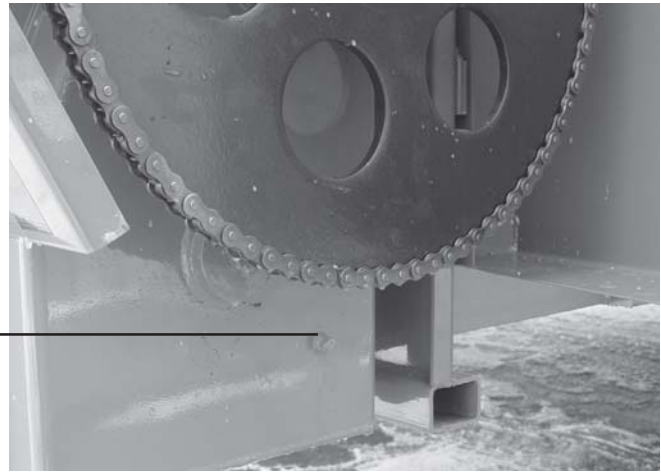

DRIVE CHAINS

Lubricate the drive chains with a light machine oil. Keeping the chains aligned with the sprockets will lengthen the life of the sprockets and chain. Lubricate the chains often.

A

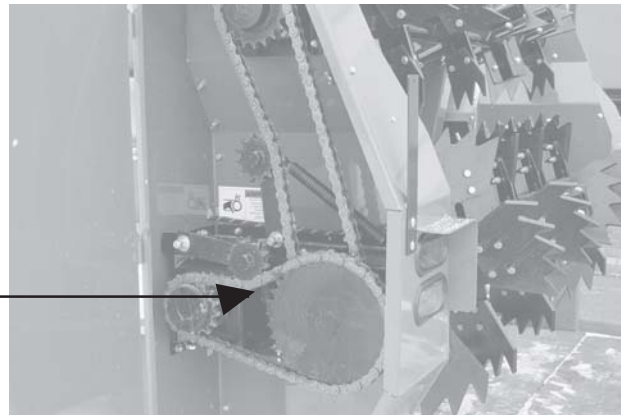

DECAL LOCATION

Your H&S Manure Spreader was manufactured with operator safety in mind. Located on the manure spreader are various decals to aid in operation, and warn of danger or caution areas. Pay close attention to all decals on your Manure Spreader.



DO NOT REMOVE ANY OF THESE DECALS. IF DECALS ARE LOST, DAMAGED, OR IF MANURE SPREADER IS REPAINTED, REPLACE DECALS. REMEMBER: DECALS ARE FOR YOUR PROTECTION AND INFORMATION.

Listed below are the decals on your Manure Spreader. These decals may be ordered individually by part number.

<u>PART #</u>	<u>QTY.</u>	<u>DESCRIPTION</u>
311	1	Patent Pending
1494A	3	Warning - Do Not Operate
1494B	2	Warning - Do Not Remove Shields
1494J	3	Warning - Do Not Work or Clear
1494K	3	Warning - Do Not Remove Shields
1494L	1	Danger - Rotating Driveline (Only on PTO)
3187	1	Speed Indicator
3494A	2	Remote Grease Zerk
66076	4	Grease Zerk Behind Shield Decal
7896B	1	Shear Bolts
8414	1	560 Logo Decal-Left
8415	1	560 Logo Decal-Right
8416	1	560 Logo Decal-Front
8417	1	660 Logo Decal-Left
8418	1	660 Logo Decal-Right
8419	1	660 Logo Decal-Front
8515	1	C.V. Joint Angle (Only on PTO)
9194A	3	Danger - No Step
9194B	1	Danger - Never Allow Riders
11599	1	Warning - Stay Clear of Hydraulic Lines
12794	4	Warning - Do Not Operate
54033	1	Made In USA 3"
71188B	1	Jack Storage Position
71494A	4	Warning - Do Not Operate
72203A	1	Warning - Help Avoid Injury
82602	1	Warning - Crush Hazard
093020	24	Grease Zerk Decal (not shown)
093366	1	Keep Operators Manual Here
102196	1	Lubrication (CV PTO)
111593A	2	Danger - Stay Clear of Beater
111593C	2	Danger - Stay Clear of Endgate Arms
123002	2	Warning - Stay Clear of Endgate Arms
DCAMB	6	Amber Reflector
DCRED	2	Red Reflector
JD5922	2	Orange Non Reflector

DECAL LOCATION

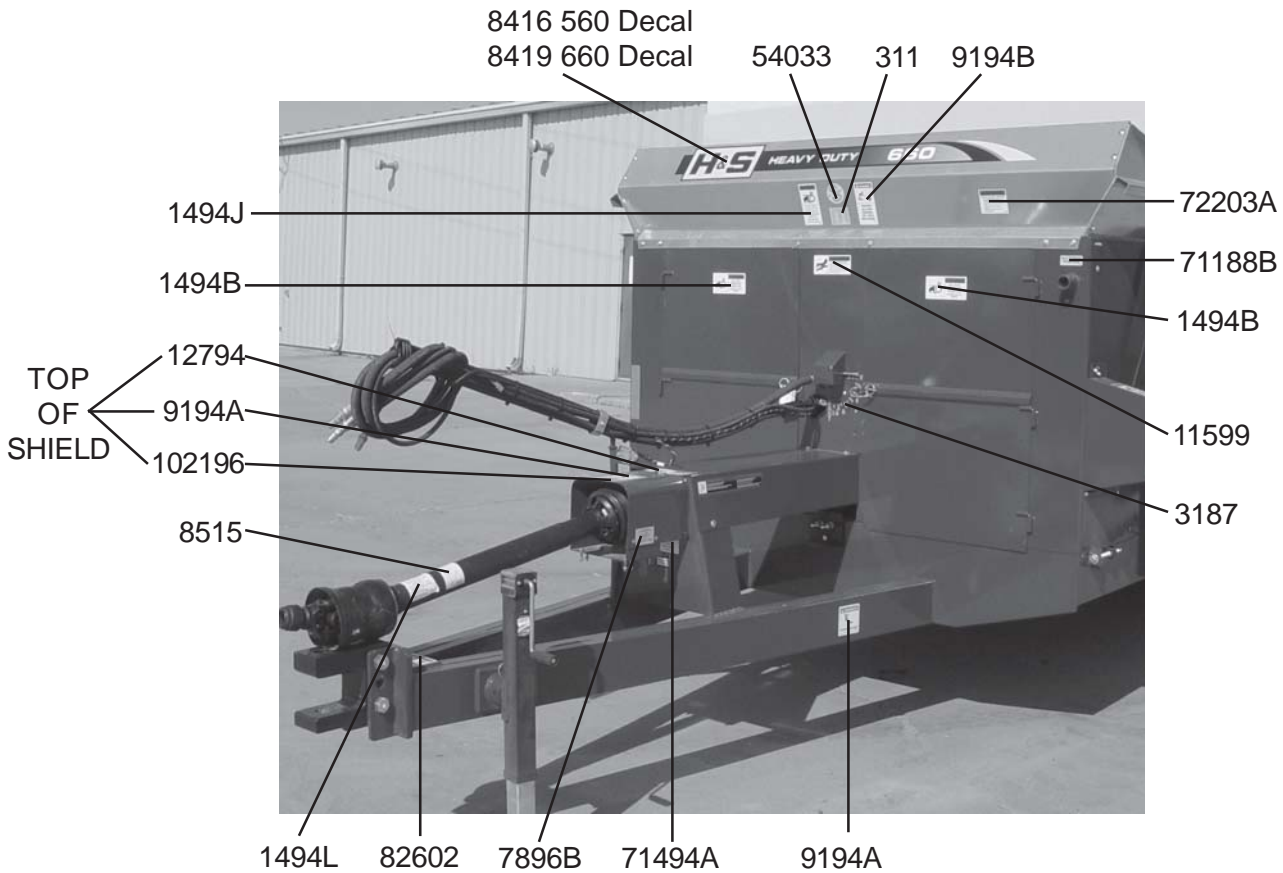

DECAL LOCATION

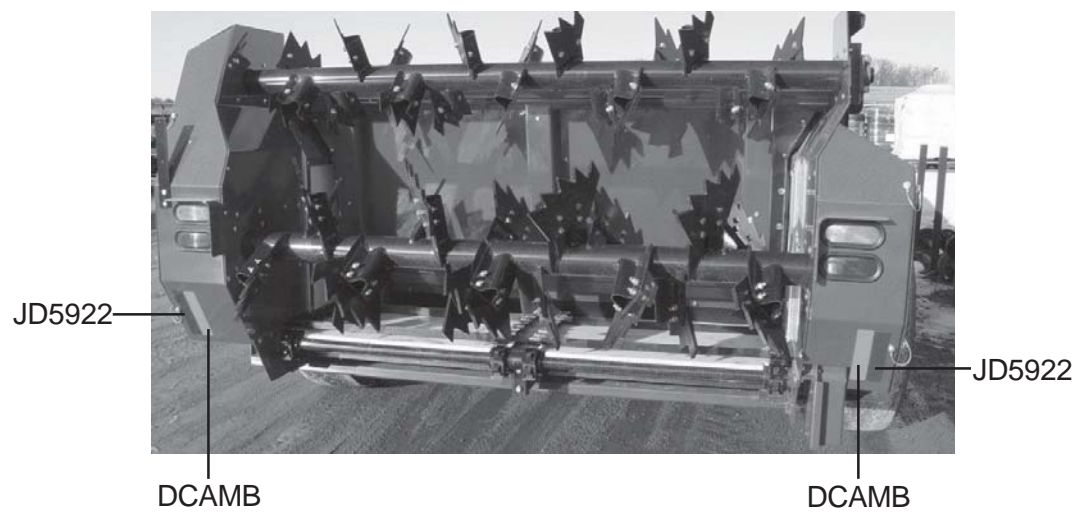
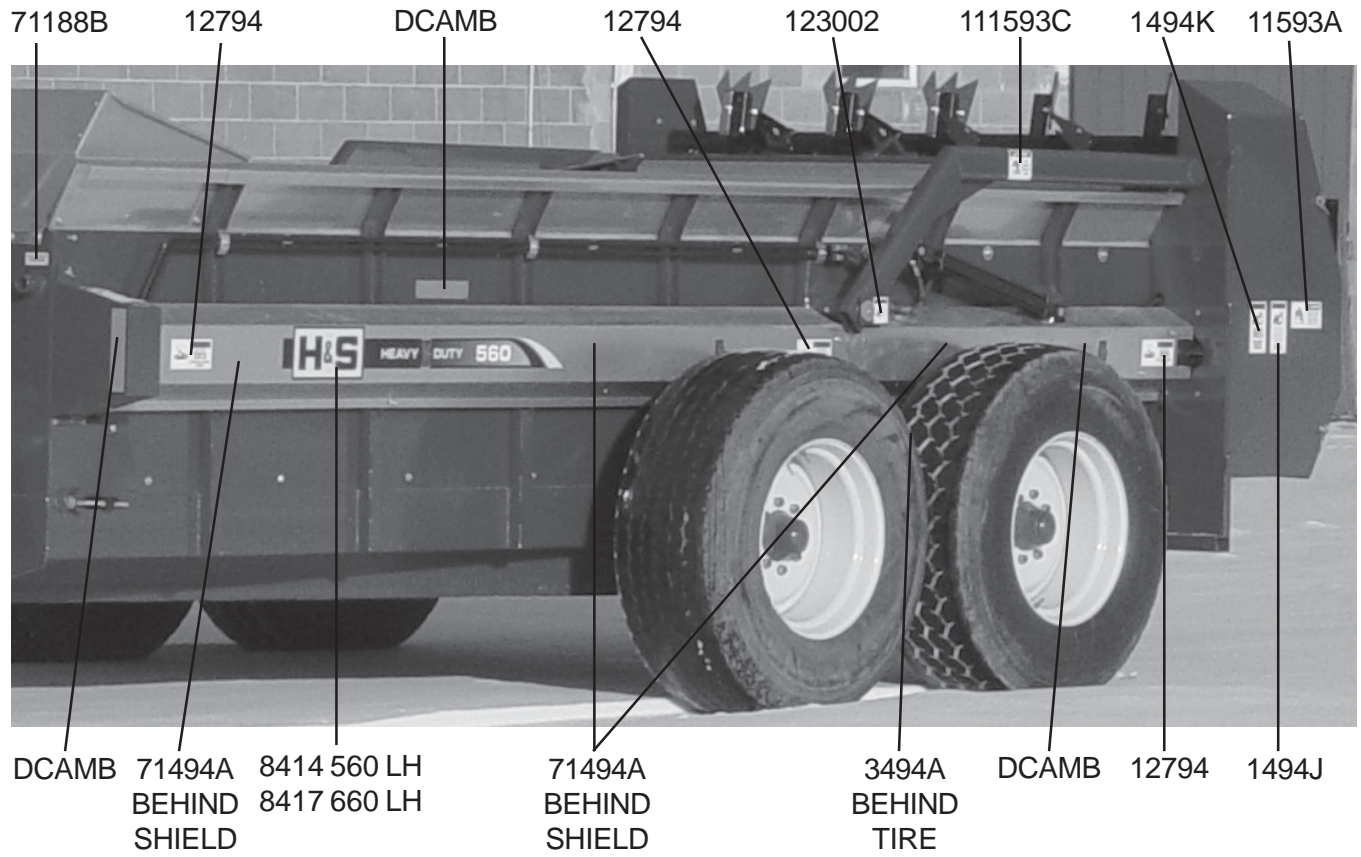

DECAL LOCATION

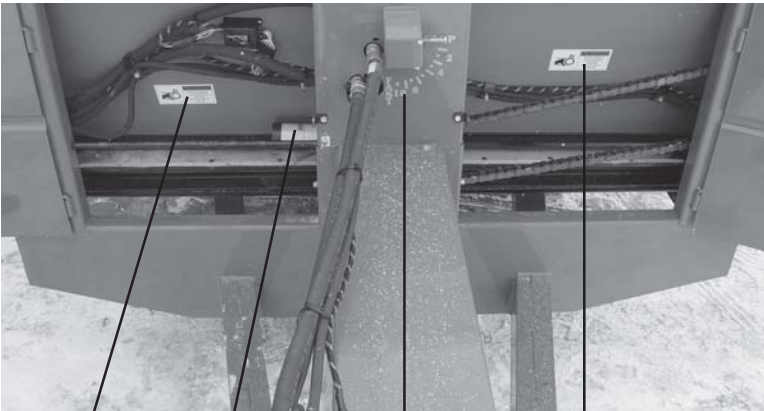

1494A

093366

3187

1494A

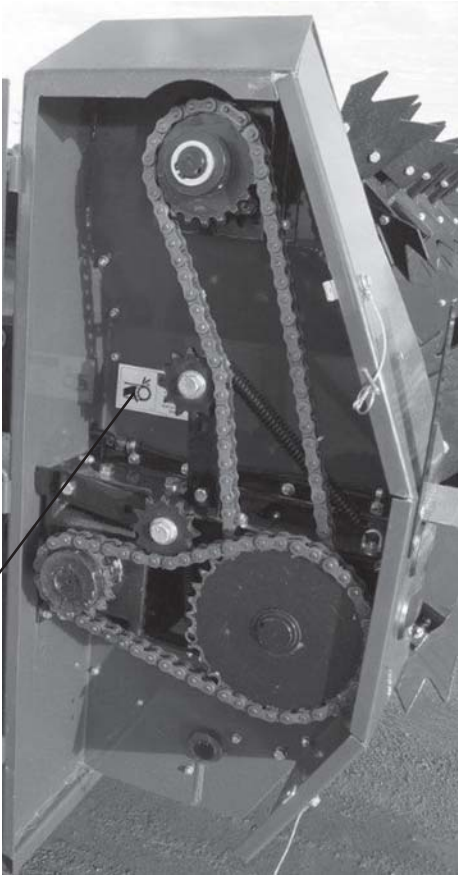

1494A

TROUBLE SHOOTING



WARNING:

MAKE SURE THAT THE TRACTOR IS SHUT OFF AND THE MANURE SPREADER CAN NOT MOVE BEFORE SERVICING. MAINTENANCE AND REPAIR SERVICE WORK TO BE PERFORMED BY A QUALIFIED SERVICE PERSON ONLY.

TROUBLE...	POSSIBLE CAUSE...	POSSIBLE REMEDY...
Beater Does Not Turn	PTO Not Turning	Engage Tractor PTO
	PTO Shaft Shear Bolt Sheared	Replace PTO Shaft Shear Bolt
	Front Drive Chain Off, Broken, or Missing	Replace or Repair Front Drive Chain
	Primary Beater Drive Chain Off, Broken, or Missing	Replace or Repair Primary Beater Drive Chain
	Key Sheared or Missing on Beater Drive or Driven Sprocket	Replace Sheared or Missing Key
Top Beater Does Not Turn	Secondary Beater Drive Chain Off, Broken, or Missing	Replace or Repair Secondary Beater Drive Chain
Apron Does Not Turn	Tractor Hydraulics Not Engaged	Engage Tractor Hydraulics
	Apron Drive Chain Off, Broken, or Missing	Replace or Repair Apron Drive Chain
	Insufficient Tractor Hydraulic Pressure	Change Tractors

SERVICE NOTES

SPECIFICATIONS

	<u>560</u>	<u>660</u>
Top Flare Width.	89-1/2"	89-1/2"
Inside Width.	80"	80"
Inside Length.	17'-5"	17'-5"
Inside Depth.	36"	49"
Overall Width w/Standard Truck Tires.	130"	130"
Overall Width w/Optional 21.5L x 16.1 Tires.	142-1/2"	N/A
Spindle Size.	3"	3"
Overall Length.	26'-10"	26'-10"
Overall Loading Height (Top of Flare).	63-3/8"	73-3/4"
Overall Height w/Hyd. Endgate.	78"*	83"
Diameter of Beater.	29"	29"
Diameter of Top Beater.	20"	20"
Weight w/Standard Tires.	8140#	9700#
Capacity (Old Rating).	560 Bu	660 Bu.
Capacity - Cu. Ft. Struck Level.	353.	479
Rear Hydraulic Endgate.	Standard	Standard
Semi Liquid Rear Pan.	Optional	Optional
Upper Beater.	Standard	Standard
Variable Speed Hydraulic Drive.	Standard	Standard
Front Splash Panel.	Standard	Standard
PTO Speed.	1000 RPM Standard/540RPM Optional.	1000 RPM
Hydraulic Cylinder on Hydraulic Endgate.	Two.	Two

* Overall Height is Height to Top of Upper Beater

*** SPECIFICATIONS ARE SUBJECT TO CHANGE WITHOUT PRIOR NOTICE.**

H&S MFG. CO.

products approved

for the

FEMA

SEAL OF QUALITY

